



TABLE OF CONTENTS

FAN FEATURES	3
Fan design	4
Fan installation in the ventilation network	5
ENERGY EFFICIENT AXIAL FANS	7
OZA 300, OZA 301 axial fans	7
OZA-F 300, OZA-F 301 high-pressure axial fans	35
OZA-RV reversible axial fans	57
OZA-HD 301 low-speed axial fans	67
ADDITIONAL EQUIPMENT	82
OZA-GKK silencer	82
OZA-KLR universal check valve	86
OZA-MOP, OZA-MOB mounting supports	88
OZA-FOT counter flange	89
OZA-ZNT weather protection hood	90
OZA-VKO inlet header	91
OZA-COM flexible connector	92
OZA-PEP flat adapter	93
OZA-PET toroidal adapter	94
OZA-PEK roof adapter	95
OZA-PUV straight section of the duct	96
OZA-R50 decorative grille	97
OZA-SEM, OZA-SEB protective mesh	99
ASC-150, ASC-310 frequency converter	100
SAU-PPV, SAU-SPV fan control cabinet	101





AXIAL FANS

AXIAL FAN
long casing (design 01)
OZA 300, OZA 301
•N •CR1 •V •VCR1



p. 7

AXIAL FAN
short casing (design 02)
OZA 300, OZA 301
•N •CR1 •V •VCR1



p. 7

HIGH-PRESSURE
AXIAL FAN
OZA-F 300, OZA-F 301
•N •CR1 •V •VCR1



p. 35

ВЕНТИЛЯТОР ОСЬОВИЙ
реверсивний
OZA-RV
•N •CR1 •T



p. 57

ВЕНТИЛЯТОР ОСЬОВИЙ
тихохідний
OZA-HD
•N •CR1



p. 67

ADDITIONAL EQUIPMENT

OZA-GKK
silencer



p. 82

OZA-KLR
universal check valve



p. 86

OZA-MOP, OZA-MOB
mounting support



p. 88

OZA-FOT
counter flange



p. 89

OZA-ZNT
weather protection hood



p. 90

OZA-VKO
inlet header



p. 91

OZA-COM
flexible connector



p. 92

OZA-PEP
flat adapter



p. 93

OZA-PET
toroidal adapter



p. 94

OZA-PEK
roof adapter



p. 95

OZA-PUV
straight section of the duct



p. 96

OZA-R50
decorative grille



p. 97

OZA-SEM, OZA-SEB
protective mesh



p. 99

ASC-150, ASC-310
frequency converter



p. 100

SAU-PPV, SAU-SPV
fan control cabinet



p. 105

ENERGY EFFICIENT AXIAL FANS

OZA 300, OZA 301 axial fans are a modern energy-efficient solution that is characterized by high efficiency of the fan itself, high selection accuracy with a minimum margin. The combination of the listed advantages also allows reducing the installed and especially consumed power by 20-30% compared to analogues.

OZA 300, OZA 301 axial fans are compact and easy to install, as well as much more energy efficient compared to radial and roof fans. The most promising series of fans with the ability to adjust the angle of the impeller blade - OZA 300, OZA 301. OZA 300, OZA 301 axial fans feature an extended standard size range. Thanks to this, there are many (more than 300) different options for flow rate and pressure.

FEATURES OF OZA 300, OZA 301 FANS

- aluminum impeller with variable-incidence volumetric blades made by using injection molding;
- flow rate from 500 to 120,000 m³/h, head up to 1,800 Pa;
- motor speed from 75 to 3,000 rpm;
- total efficiency (up to 75%) exceeds all domestic analogues;
- aerodynamically optimized motor housing and mounts.



OZA 300, OZA 301 AXIAL FANS DISTINGUISHED BY A NUMBER OF ADVANTAGES

- wall mounting without additional supports up to size 063;
- use of light-weight suspensions up to size 125, without requiring a special ventilation chamber;
- low energy consumption at the same flow rates as roof fans (at a pressure of 50-200 Pa), which allows for a 1.5-3-fold reduction in the total installed motor power;
- a wide range of versions provides accuracy of up to 1-3% due to numerous options, thereby reducing the overall reserve of the installed power of the motors;
- optimal solution not only in terms of dimensions and power, but also in terms of motor service life. Bearing loads (due to impellers weight) are reduced;
- provides savings in the equipment budget by 2-3 times compared to conventional fans.



FAN DESIGN BY INTENDED PURPOSE

DESIGN	DESIGNATION	FLOW PATH	OPERATION	NOTE
general purpose industrial	N	carbon steel	for moving air and other non-explosive gas-steam-air media that do not cause corrosion of carbon steel more than 0.1 mm per year, with a content of dust and other solid impurities not exceeding 0.1 g/m ³ , free of sticky substances and fibrous materials	
corrosion-resistant	CR1	stainless steel	for moving air with an admixture of vapors and gases that are not aggressive to stainless steel, but cause accelerated corrosion of ordinary carbon steel, with a content of dust and other solid impurities not exceeding 0.1 g/m ³ , free of sticky substances and fibrous materials	
explosion-proof	V	carbon steel	for moving gas-air explosive mixtures, which do not contain explosives that cause corrosion of carbon steel more than 0.1 mm per year, with a content of dust and other solid impurities not exceeding 0.1 g/m ³ , free of sticky substances and fibrous materials	they are not used for moving gas-steam-air mixtures from technical installations where explosive substances are heated above their auto-ignition temperature or are under excessive pressure
explosion-proof corrosion-resistant	VCR1	stainless steel	for moving gas-steam-air explosive mixtures 2 according to GOST 12.1.020.78*, which do not contain explosives and are contaminated with aggressive vapors and gases, in which the corrosion rate of stainless steel does not exceed 0.1 mm per year, with a content of dust and other solid impurities not exceeding 0.1 g/m ³ , free of sticky substances and fibrous materials	

* equipment is ordered upon an individual order.

ENERGY EFFICIENT AXIAL FANS



FAN INSTALLATION IN THE VENTILATION NETWORK

The aerodynamic characteristics listed in the catalog were obtained with a free inlet and outlet section of the fan. These characteristics can be used when designing a ventilation network if the fan is properly installed in this network. If the condition of uniform flow entry into the fan is met and there is no blockage of its outlet section. If these requirements for fan installation are violated, then it is necessary to use its degraded performance characteristics, which can be obtained using the recommendations presented in the specialized literature. The reduction in pressure created by the fan can reach 10-30% or more.

Below are specific recommendations for the most common options for installing fans in ventilation systems.

AIR DUCTS AND FLEXIBLE INSERTS

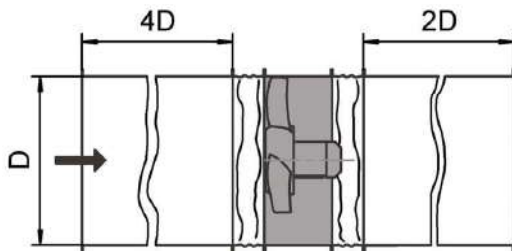

RECOMMENDED:

When installing a fan in a ventilation network, it is recommended to ensure that there are straight sections of air ducts of sufficient length with a cross-sectional area equal to the area of the inlet and outlet sections of the fan before and after the fan inlet. Reducing the length of straight sections adjacent to the fan results in a reduction in the pressure generated by the fan. The presence of flexible inserts in front and behind the fan reduces vibration and noise.

DUCT ANGLES

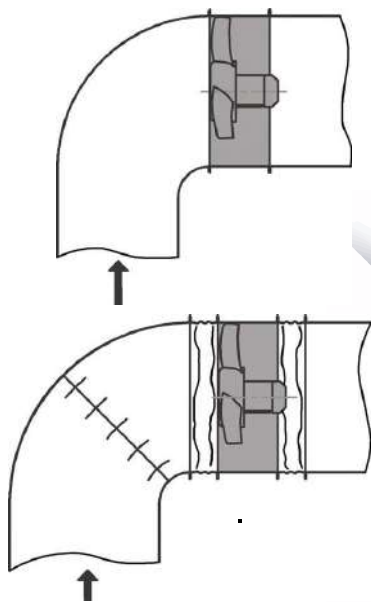

RECOMMENDED:

if it is necessary to install duct angles of the network directly near the fan, it is recommended to use a folded elbow or a duct angle with a large radius of curvature, or a duct angle with a system of blades located in it.

IT IS NOT RECOMMENDED

to use a simple duct elbow directly in front of and behind the fan. The installation of such duct angle leads to a significant decrease in fan performance and an increase in noise generated.

ADAPTERS

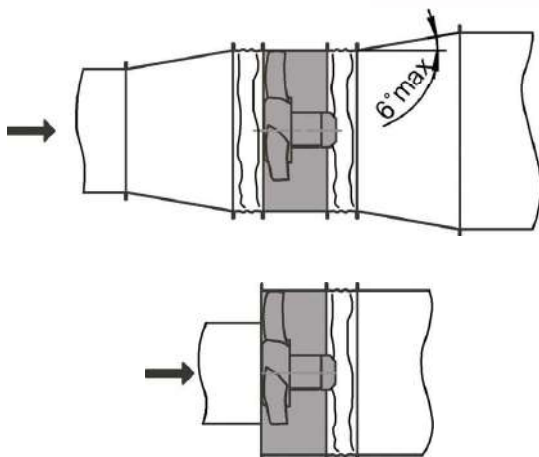

RECOMMENDED:

if the cross-sectional area of the air duct in front of the fan is larger or smaller than the inlet cross-sectional area of the fan, it is recommended to install adapters in the form of a diffuser or confuser between the air duct and the fan.

IT IS NOT RECOMMENDED

to place an air duct with a smaller cross-section than the fan inlet directly in front of the inlet. This disrupts the normal operation of the fan: efficiency and pressure are reduced.



DISCHARGE OPERATION

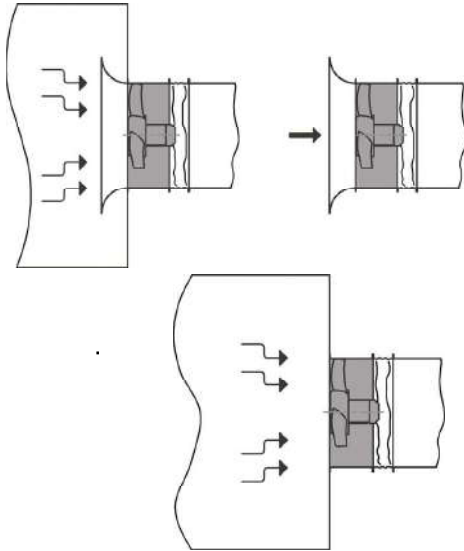

RECOMMENDED
if the network is located on the discharge side and the inlet is free, it is recommended to install the inlet header in front of the fan.

IT IS NOT RECOMMENDED
to leave the flange when the flow is freely flowing into the axial fan.

SUCTION OPERATION

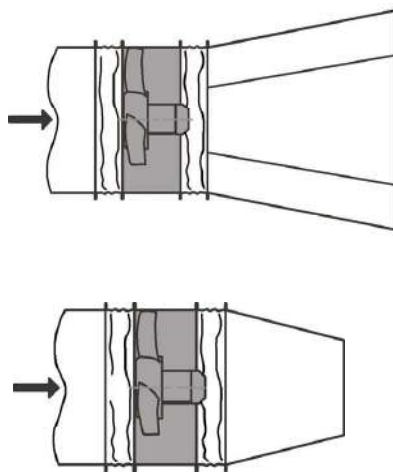

RECOMMENDED
when the network is located on the suction side and the outlet section is free, it is recommended to install a diffuser at the fan outlet to reduce the speed and dynamic pressure of the fans.

IT IS NOT RECOMMENDED
to place a confuser at the fan outlet, which increases the axial component of the flow velocity and swirl, as well as unused dynamic pressure.

INDOOR LOCATION

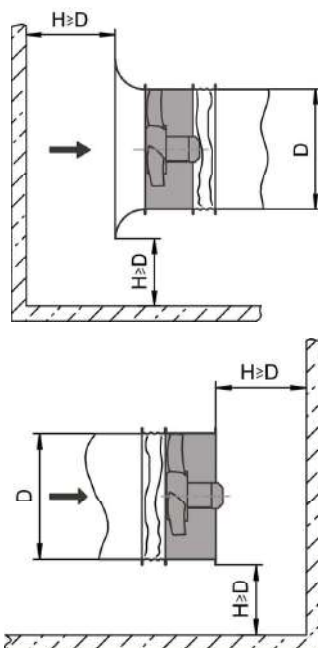

RECOMMENDED
it is recommended that for normal operation of the fan in a confined space, the specified minimum permissible distances from the inlet and outlet sections to nearby walls of the room, obstacles and large-sized equipment be observed.





ENERGY EFFICIENT AXIAL FANS

OZA 300, OZA 301

low-and medium-pressure axial fans of the OZA300, OZA301 series consist of a new design impeller, an all-welded casing made of rolled sheet and an asynchronous motor located in the casing. Thanks to its special aerodynamic shape, the motor support stand serves as a guide apparatus.

- ▀ ventilation and air heating systems;
- ▀ sanitary and technological installations;
- ▀ positive pressure ventilation systems (PD-systems).

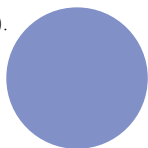

•040 •045 •050 •056 •063 •071 •080 •090 •100 •112 •125

The impeller is made with variable-incidence blades, the setting angle of the blade is adjustable for maximum efficiency. The volumetric blades are made by using injection molding. The air flow cross-section is maximized, which gives a significant reduction in the outlet speed. Thanks to the new design of the impeller, the fans are designed with the highest static efficiency at static pressure values of 100-900 Pa.

The flanges of the fan casing are edge-raised, providing increased rigidity and precision, and ensuring the same minimum radial clearance between the impeller blades and the casing along the perimeter of the impeller. The casing is made of aluminum, stainless or carbon steel.

If there is no network at the inlet, it is necessary to use the OZA-KVO inlet header or the OZA-PET toroidal adapter.

The flow direction is always from the impeller to the motor, regardless of orientation. All elements of the fan casing feature a protective and decorative paint coating.

Fans are made in two types of casing design: long case (01) and short case (02). The short fan casing does not completely cover the motor and characterized by light weight.

Additional equipment options are available - see the "Additional equipment" section.

- ▀ general purpose industrial (N);
- ▀ corrosion-resistant (CR1);
- ▀ explosion-proof (V);
- ▀ explosion-proof corrosion-resistant (CRV1).

OPERATING CONDITIONS:

- ▀ ambient temperature
 - від -40° C до +40° C (OZA 300, OZA 301);
 - від -60° C до +40° C (OZA 300);
- ▀ the average value of vibration velocity of external vibration sources at the fan installation locations is no more than 2 mm/s;
- ▀ conditions for the air mixture to be moved are presented in the table "Conditions for the air mixture to be moved".





EXAMPLE:

OZA 301 axial fan, size 080/L, impeller blade angle 50°, general purpose industrial design, nominal motor power $N_{nom} = 0.75$ kW, number of poles 6, climatic version Y2, casing type 02

OZA 301-080/L-50-N-00075/6-Y1-02

- ▶ energy efficient axial fan (•OZA 300 •OZA 301 (lightweight wheel!))
- ▶ fan size (•040 •045 •050 •056 •063 •071 •080 •090 •100 •112 •125)
- ▶ impeller modification (•A •B •C •D •E •I •L •M •P •R •S •T)
- ▶ impeller blade angle α , deg (•40... •70)
- ▶ design (•N •CR1 •V •VCR1)
- ▶ motor parameters²: •I/P
 - ↳ -Motor Power Index - see Table 1
 - P - number of poles: 2 (3 000 rpm) 4 (1 500 rpm) 6 (1 000 rpm) 8 (750 rpm)
- ▶ climatic version •Y1 •Y2 •YHL1 (OZA 300 only)
- ▶ casing type (•1 fully enclosed casing; •2 features minimum possible length)

NOTE:

¹ The lightweight impeller design is used for less demanding tasks (clean air without impurities) and is not used in explosion-proof version..

² By default all supplied motors are designed for 380 V, 50 Hz, direct start. Design types of other voltages and connection methods are available upon special agreement.

³ The Motor Power Index is shown in the Table.

Special requirements for the fan are specified additionally and agreed upon with the manufacturer.

OZA MOTOR POWER INDEX

Nominal power (N_{nom}), kW	0,18...0,75	1,1...7,5	11...90
Motor Power Index (I)	00018...00075	00110...00750	01100...09000

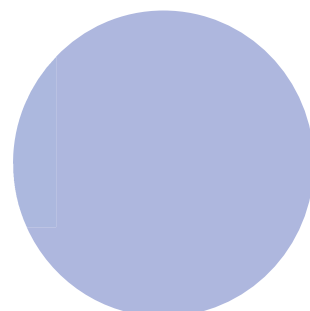



DYNAMIC PRESSURE VALUE (P_{dv}, Pa) FOR ROUND DUCTS

Flow rate, m ³ /h	Round duct diameter, dm										
	4	4,5	5	5,6	6,3	7,1	8	9	10	11,2	12,5
7000	143,4	89,5	58,8	37,3	23,3	14,4					
7500	164,7	102,8	67,4	42,9	26,8	16,6	10,3				
8000	187,3	117,0	76,7	48,8	30,4	18,9	11,7				
8500	211,5	132,0	86,6	55,1	34,4	21,3	13,2				
9000	237,1	148,0	97,1	61,7	38,5	23,9	14,8				
10000		182,7	119,9	76,2	47,6	29,5	18,3	11,4			
11000		221,1	145,1	92,2	57,6	35,7	22,1	13,8	9,1		
12500		285,5	187,3	119,1	74,3	46,1	28,6	17,8	11,7		
13000		308,8	202,6	128,8	80,4	49,8	30,9	19,3	12,7		
14000			235,0	149,3	93,2	57,866,4	35,9	22,4	14,7		
15000			269,8	171,4	107,0	90,3	41,2	25,7	16,9	10,7	
17500				233,4	145,7	118,0	56,0	35,0	22,9	14,6	
20000				304,8	190,3	149,3	73,2	45,7	30,0	19,0	12,3
22500				385,8	240,8	184,3	92,6	57,8	37,9	24,1	15,5
25000				476,2	297,3	223,0	114,3	71,4	46,8	29,8	19,2
27500					359,8	265,4	138,4	86,4	56,7	36,0	23,2
30000					428,1	311,5	164,7	102,8	67,4	42,9	27,6
32500					502,5	361,2	193,2	120,6	79,2	50,3	32,4
35000					582,7	414,7	224,1	139,9	91,8	58,3	37,6
37500						471,8	257,3	160,6	105,4	67,0	43,2
40000						532,7	292,7	182,7	119,9	76,2	49,1
42500							330,5	206,3	135,4	86,0	55,4
45000							370,5	231,3	151,7	96,4	62,2
47500							412,8	257,7	169,1	107,5	69,3
50000								285,5	187,3	119,1	76,7
55000								345,5	226,7	144,1	92,9
60000								411,2	269,8	171,4	110,5
65000								482,6	316,6	201,2	129,7

For all types of fans, the definition of static P_{sv} (P_{st}), dynamic P_{dv} (P_{in}) and total pressure P_v (P_{tot}) is accepted (the designations used in the USA and EU are given in brackets). In catalogs, the formula $P_v = P_{dv} + P_{sv}$ or $P_{sv} = P_v - P_{dv}$ is given with detailed explanations, but many manufacturers neglect additional information or, moreover, resort to incorrect notation: P is some pressure, without specifying the total or some other. This "forgetfulness" is easy to understand, since the pressure required to overcome the frictional resistance of the duct is only P_{sv}. Thus, it is necessary to compare the fans very carefully and understand what pressure the manufacturer showed on the graphs or in the tables.

In many cases, the fan is selected at the very "limit" of the characteristic, when the dynamic pressure is equal to the total (P_{dv}=P_v), and the static pressure is completely absent (P_{sv}=0!). Thus, the customer can purchase a fan that is incapable of operating under design conditions, but formally features total pressure strictly according to the design.

For OZA 300 models all data are shown for total pressure (P_v), additional information for dynamic pressure (P_{dv}) can be found in the table or on the fan graphs. For fans designed for PD systems, the data are shown in the EV catalog only for static pressure (P_{sv}) and conversion to total pressure is possible using the table "Dynamic pressure values for round ducts".

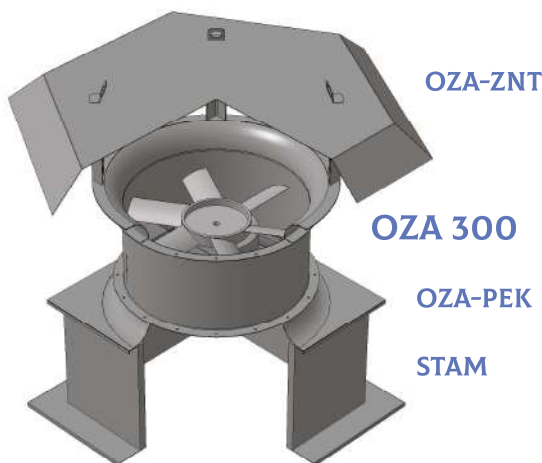



COMPLETE SET OF FANS WITH ELECTRIC MOTORS

Number of poles	Nnom, kW	Motor size	Standard size										
			040	045	050	056	063	071**	080	090	100	112	125
8 (750 min ⁻¹)	•1,1	90							■	■	■	■	
	•1,5	100							■	■	■	■	■
	•2,2	112								■	■	■	■
	•3	112									■	■	■
	•4	132										■	■
	•5,5	132										■	■
6 (1000 min ⁻¹)	•7,5	160										■	■
	•0,25	63			■	■							
	•0,37	71				■	■	■	■				
	•0,55	71				■	■	■	■				
	•0,75	80					■	■	■	■			
	•1,1	80					■	■	■	■	■		
	•1,5	90						■	■	■	■		
	•2,2	100							■	■	■	■	
	•3	112							■	■	■	■	
	•4	112								■	■	■	■
	•5,5	132								■	■	■	■
	•7,5	132									■	■	■
	•11	160									■	■	■
	•15	160										■	■
•18,5	180											■	
4 (1500 min ⁻¹)	•0,18	56	■	■									
	•0,25	63		■	■								
	•0,37	63		■	■	■	■						
	•0,55	71			■	■	■	■					
	•0,75	71			■	■	■	■	■				
	•1,1	80				■	■	■	■				
	•1,5	80					■	■	■	■			
	•2,2	90					■	■	■	■	■		
	•3	100						■	■	■	■	■	
	•4	100							■	■	■	■	■
	•5,5	112							■	■	■	■	■
	•7,5	132								■	■	■	■
	•11	132								■	■	■	■
	•15	160									■	■	■
	•18,5	160									■	■	■
	•22	180										■	■
	•30	180										■	■
•37	200											■	
•45	200											■	
2 (3000 min ⁻¹)	•0,55	63	■										
	•0,75	71	■										
	•1,1	71	■	■									
	•1,5	80	■	■									
	•2,2	80	■	■	■								
	•3	90		■*	■								
	•4	100		■*	■*	■	■						
	•5,5	100			■*	■	■	■					
	•7,5	112			■*	■	■	■	■				
	•11	132				■*	■*	■*	■*	■			
	•15	160						■*	■*	■*	■		
•18,5	160							■*	■*	■*	■		

NOTE:

* "N" and "CR1" fan design only

** Fans of size 071 for 3000 min⁻¹ manufactured only in the OZA301 design





AREAS OF AERODYNAMIC PARAMETERS

FREE AREA

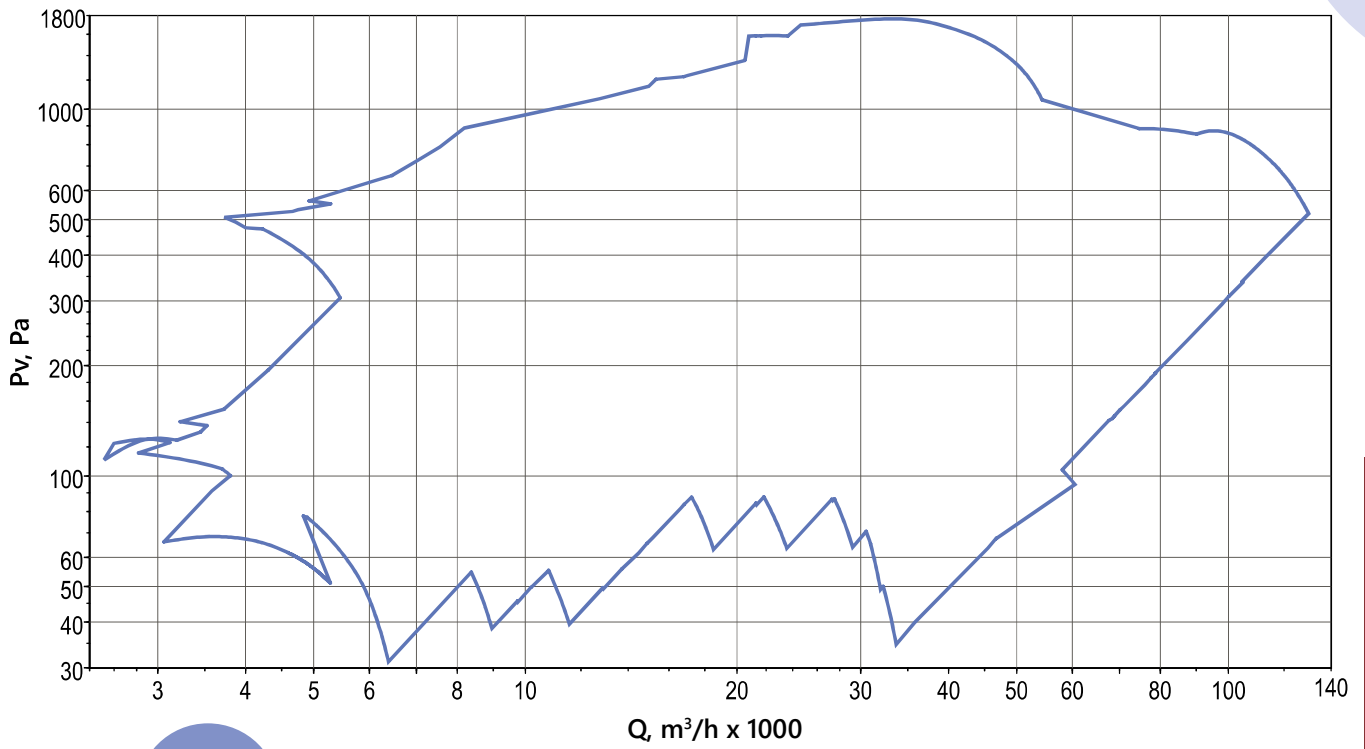

8 POLES

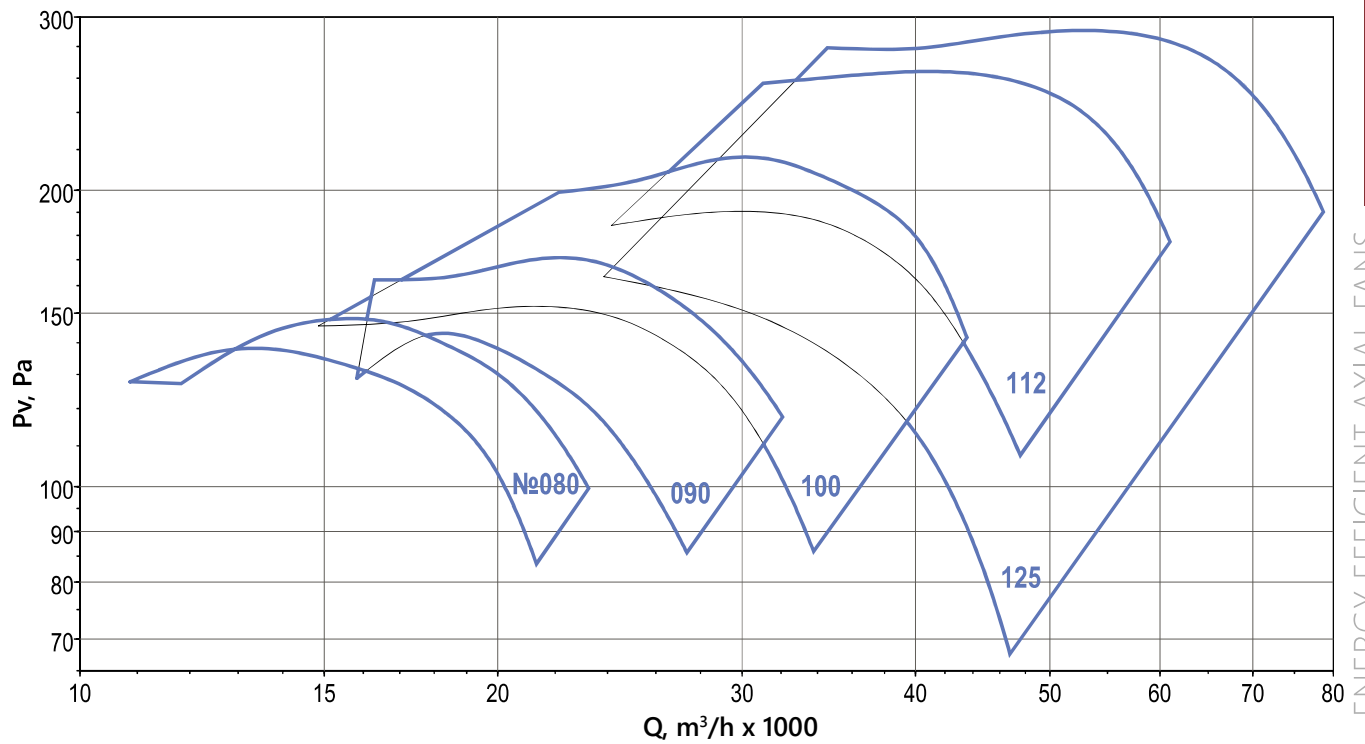



6 POLES

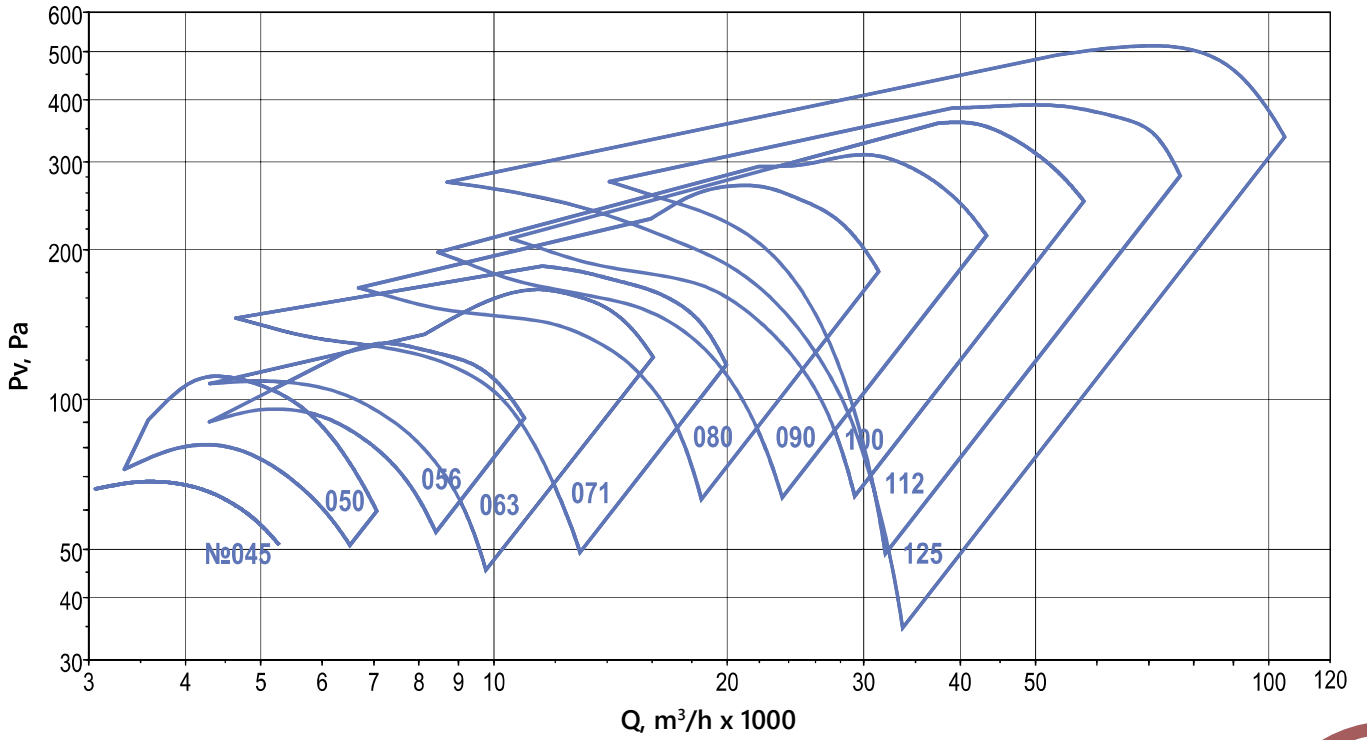

4 POLES

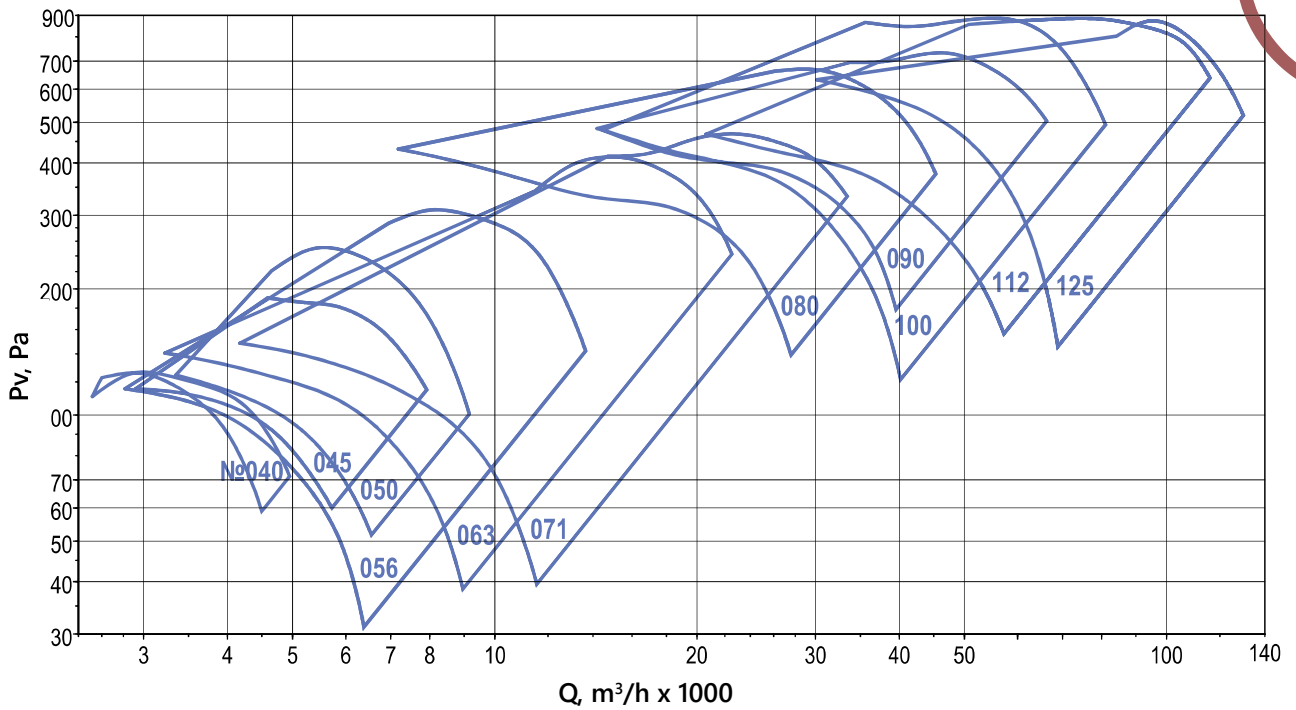



2 POLES

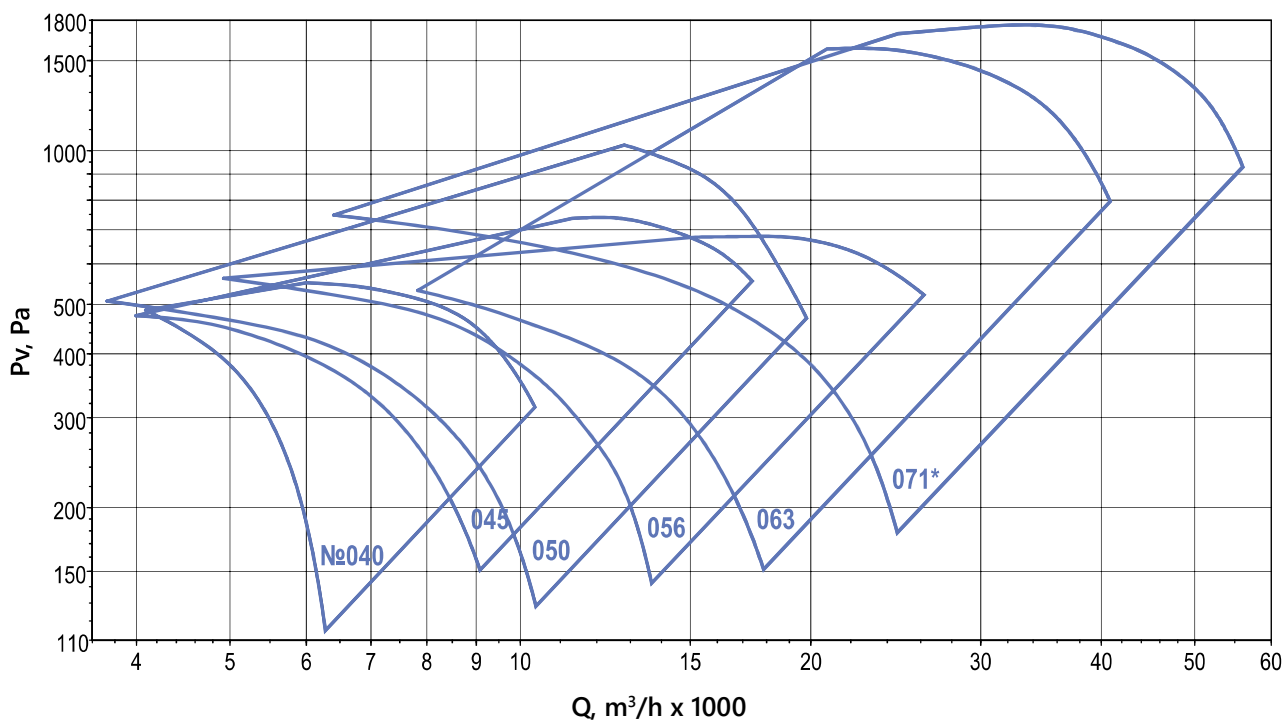



OZA 300/301-040

Curve number	Number of poles	Nnom, kW	Impeller	α, deg	Current, A at 380V	Weight*, kg	
						casing type	
						01	02
1	4	0,18**	A	40	0,73	18,7	17,7
2				45			
3				50			
4			B	50		19,5	18,5

Curve number	Number of poles	Nnom, kW	Impeller	α, deg	Current, A at 380V	Weight, kg	
						casing type	
						01	02
1	2	0,55	A	40	1,4	21,6	20,6
2		0,75		45	1,8	25,7	24,2
3		1,1		50	2,4	28	26,5
4		1,5	B	50	3,2	31,3	29,8
5		2,2		60	4,6	33,3	31,8

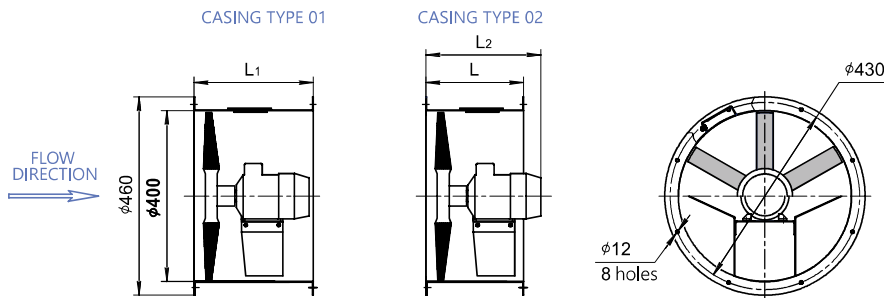
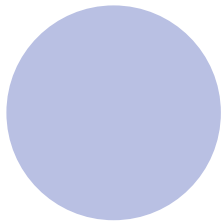
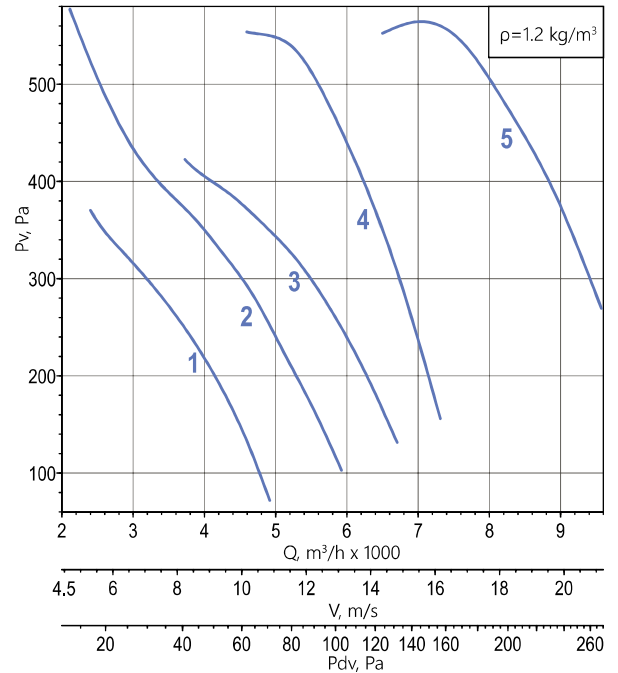
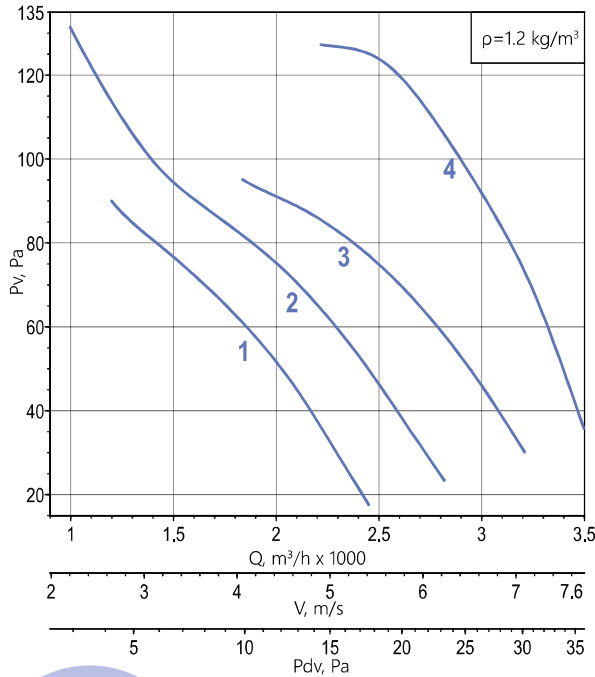

Motor size	L, mm	L1, mm	L2 max, mm
•56	280	330	330
•63	320	380	380
•71 •80	370	440	440

NOTE:

* Weight specified for OZA 300. When changing the motor type, the weight may change.

** "N" and "CR1" fan design only.

The company reserves the right to change the size and configuration without prior notice.

ADDITIONAL EQUIPMENT

silencer OZA-GKK	inlet header OZA-VKO	flat adapter OZA-PEP	counter flange OZA-FOT	protective mesh OZA-SEM, OZA-SEB
check valve OZA-KLR	mounting support OZA-MOP	roof adapter OZA-PEK	weather protection hood OZA-ZNT	
grille OZA-R50	flexible connector OZA-COM	toroidal adapter OZA-PET	frequency converter ASC	straight section of the duct OZA-PUV
fan control cabinet SAU-PPV, SAU-SPV (up to 7.5 kW) separate cabinet for each motor				





OZA 300/301-045

Curve number	Number of poles	Nnom, kW	Impeller	α, deg	Current, A at 380V	Weight*, kg	
						casing type	
						01	02
1	4	0,18**	A	45	0,73	19,8	18,8
2				50			
3				52			
4		0,25	B	50	0,83	22,6	21,6
5		0,37	B	52	1,18	23,5	22,5
6				55			
7				57			
8		60					

Curve number	Number of poles	Nnom, kW	Impeller	α, deg	Current, A at 380V	Weight, kg	
						casing type	
						01	02
1	2	1,1	A	45	2,4	29,1	27,6
2		1,5		50	3,2	31,6	30,1
3		2,2		52	4,6	33,6	32,1
4		3**	B	50	6,5	39	36,5
5				52			
6				55			
7		4**	B	57	8,4	43,5	41,5
8				60			

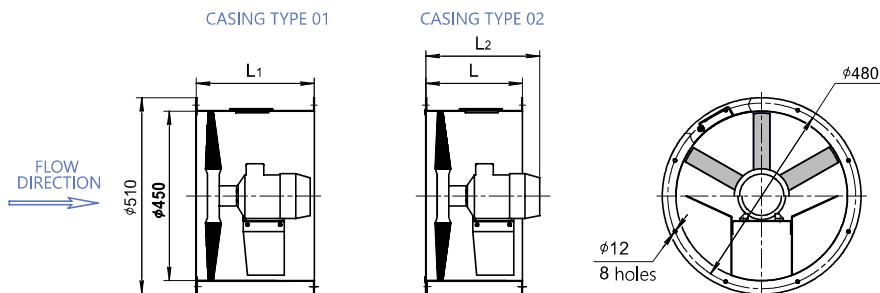
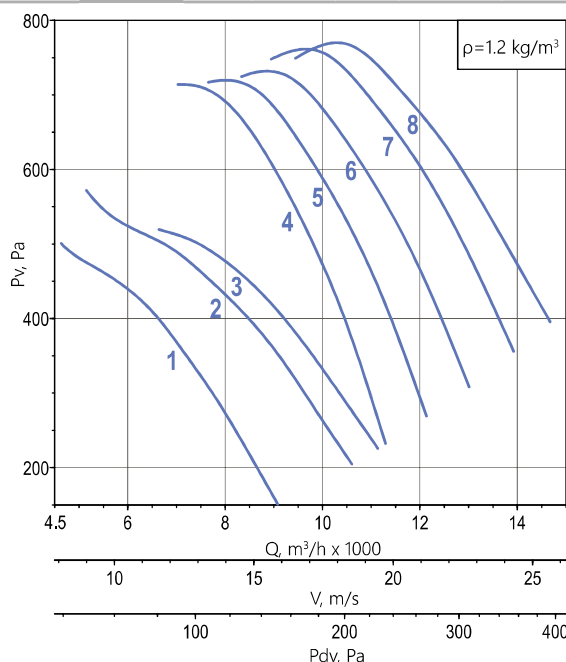
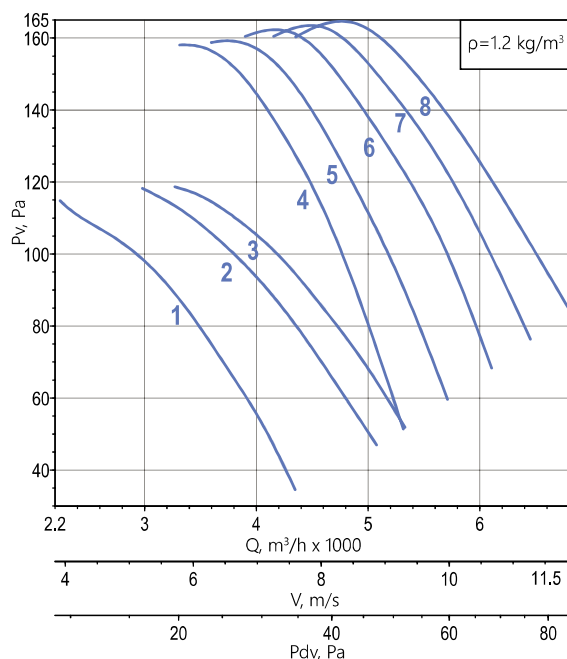

Motor size	L, mm	L1, mm	L2 max, mm
•56	280	330	330
•63	320	380	380
•71 •80	370	440	440
•90 •100	420	510	510

NOTE:
 * Weight specified for OZA 300. When changing the motor type, the weight may change.
 ** "N" and "CR1" fan design only.
 The company reserves the right to change the size and configuration without prior notice.

ADDITIONAL EQUIPMENT

silencer OZA-GKK	inlet header OZA-VKO	flat adapter OZA-PEP	counter flange OZA-FOT	protective mesh OZA-SEM, OZA-SEB
check valve OZA-KLR	mounting support OZA-MOP	roof adapter OZA-PEK	weather protection hood OZA-ZNT	
grille OZA-R50	flexible connector OZA-COM	toroidal adapter OZA-PET	frequency converter ASC	straight section of the duct OZA-PUV
fan control cabinet SAU-PPV, SAU-SPV (up to 7.5 kW) separate cabinet for each motor				





OZA 300/301-050

Curve number	Number of poles	Nnom, kW	Impeller	α, deg	Current, A at 380V	Weight*, kg	
						casing type	
						01	02
1	6	0,25	B	50	1,04	29,8	26,8
2				52			
3				55			
4				57			
5				60			

Curve number	Number of poles	Nnom, kW	Impeller	α, deg	Current, A at 380V	Weight, kg	
						casing type	
						01	02
1	4	0,25	A	50	0,83	28,3	25,3
2		0,37	B	47	1,18	30,2	27,2
3		0,55		50	1,5	32,7	29,7
4				52			
5				55			
6		0,75		57	2,2	34,2	31,2
7			60				

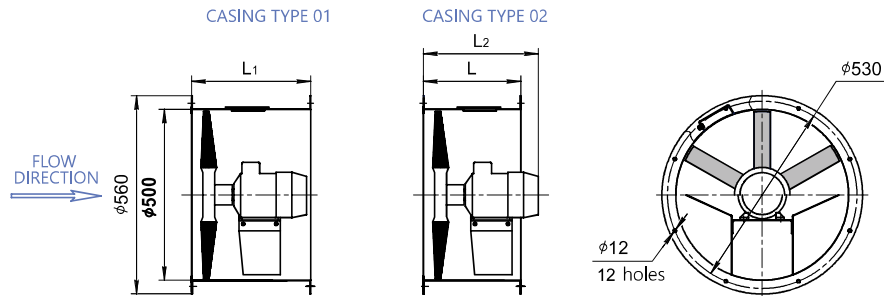
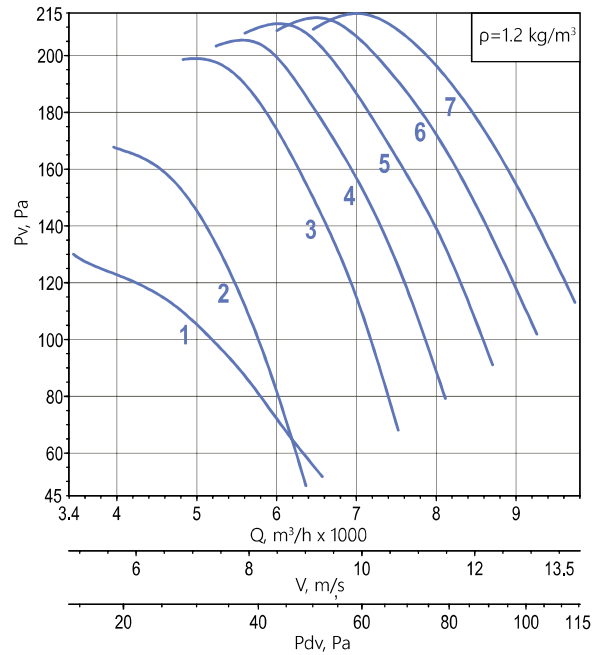
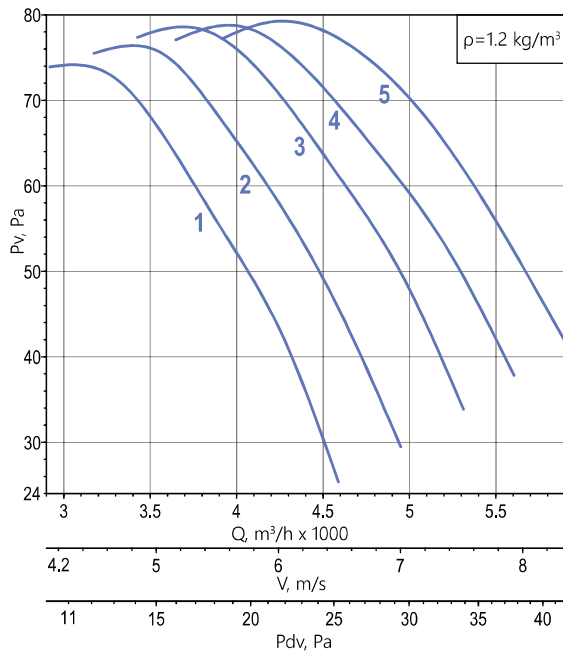

Motor size	L, mm	L1, mm	L2 max, mm
•63	320	380	380
•71	370	440	440

NOTE:
 * Weight specified for OZA 300. When changing the motor type, the weight may change.
 The company reserves the right to change the size and configuration without prior notice.

ADDITIONAL EQUIPMENT

silencer OZA-GKK	inlet header OZA-VKO	flat adapter OZA-PEP	counter flange OZA-FOT	protective mesh OZA-SEM, OZA-SEB
check valve OZA-KLR	mounting support OZA-MOP	roof adapter OZA-PEK	weather protection hood OZA-ZNT	
grille OZA-R50	flexible connector OZA-COM	toroidal adapter OZA-PET	frequency converter ASC	straight section of the duct OZA-PUV

fan control cabinet
SAU-PPV, SAU-SPV
 (up to 7.5 kW) separate cabinet for each motor





OZA 300/301-050

Curve number	Number of poles	Nnom, kW	Impeller	α , deg	Current, A at 380V	Weight*, kg	
						casing type	
						01	02
1	2	2,2	A	50	4,6	38,2	35,2
2		3	B	47	6,5	44,2	41,2
3		4**		50	8,4	49,2	46,2
4		52		11	55	58,2	55,2
5		57			81,2	78,2	
6		60			14,7		
7		7,5**					

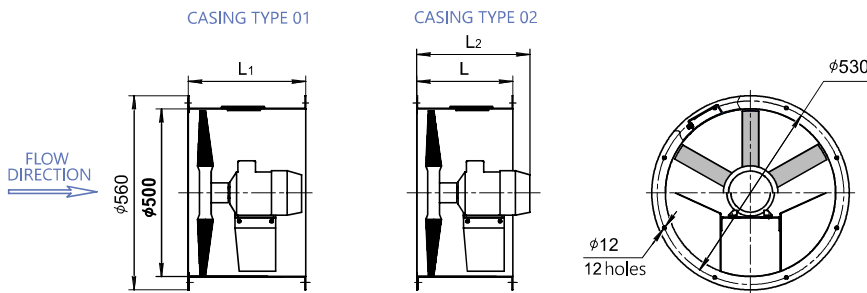
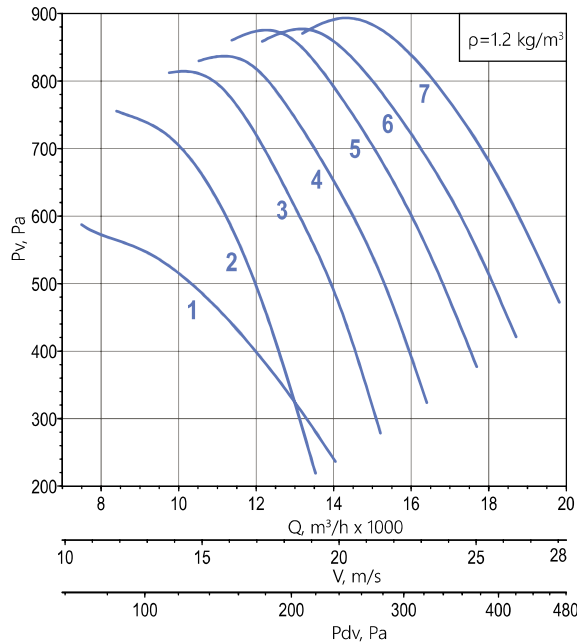

Motor size	L, mm	L1, mm	L2 max, mm
•80	370	440	440
•90 •100	420	510	510
•112	515	625	625

NOTE:
 * Weight specified for OZA 300. When changing the motor type, the weight may change.
 ** "N" and "CR1" fan design only.
 The company reserves the right to change the size and configuration without prior notice.

ADDITIONAL EQUIPMENT				
silencer OZA-GKK	inlet header OZA-VKO	flat adapter OZA-PEP	counter flange OZA-FOT	protective mesh OZA-SEM, OZA-SEB
check valve OZA-KLR	mounting support OZA-MOP	roof adapter OZA-PEK	weather protection hood OZA-ZNT	
grille OZA-R50	flexible connector OZA-COM	toroidal adapter OZA-PET	frequency converter ASC	straight section of the duct OZA-PUV
fan control cabinet SAU-PPV, SAU-SPV (up to 7.5 kW) separate cabinet for each motor				





OZA 300/301-056

Curve number	Number of poles	Nnom, kW	Impeller	α , deg	Current, A at 380V	Weight*, kg	
						casing type	
						01	02
1	6	0,25	B	55	1,04	30	28
2				57			
3			L	55		31	29
4		0,37	L	57	1,31	34	32
5				60			
6				62			
7		0,55	L	65	1,74	35,3	33,3
8				67			
9				70			

Curve number	Number of poles	Nnom, kW	Impeller	α , deg	Current, A at 380V	Weight, kg	
						casing type	
						01	02
1	4	0,37	A	50	1,18	29,3	27,3
2				52			
3		0,55	A	55	1,5	31,8	29,8
4				50			
5		0,75	B	52	2,2	34,4	32,4
6				55			
7		1,1	B	57	2,6	38,4	36,4
8				60			
9		1,5	L	62	3,6	41,4	39,4
10				65			
11		2,2	L	67	5,1	49,4	47,4
12				70			

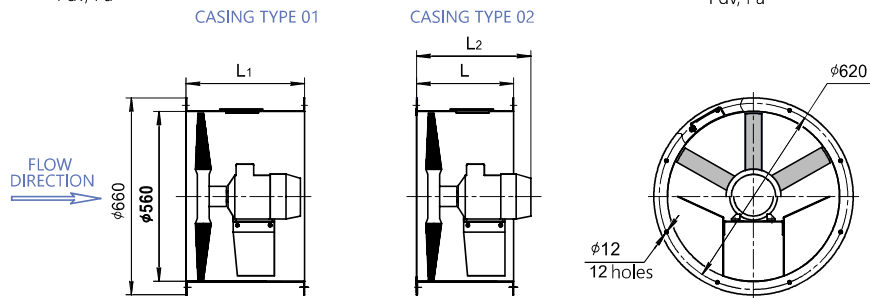
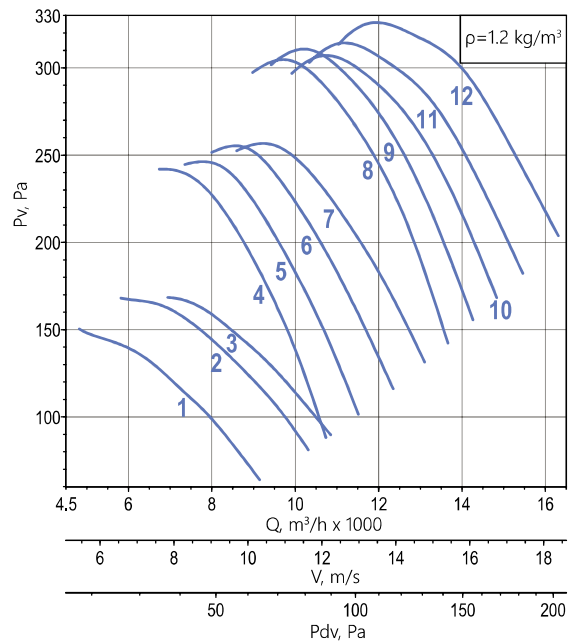
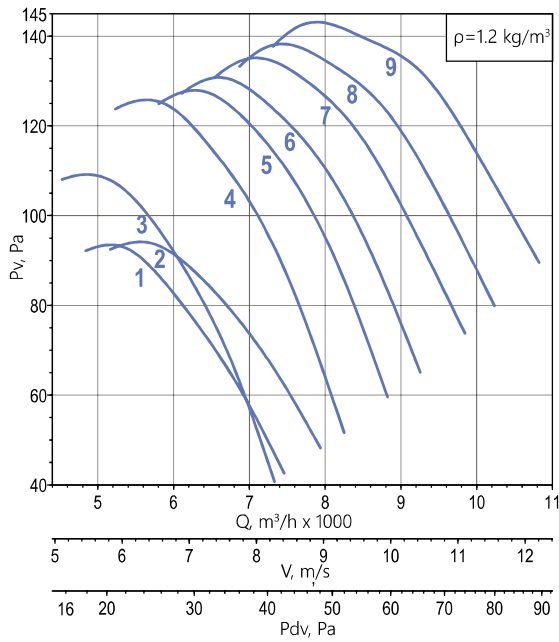

Motor size	L, mm	L1, mm	L2 max, mm
•63 •71 •80	370	440	440
•90	420	510	510

NOTE:
 * Weight specified for OZA 300. When changing the motor type, the weight may change.
 The company reserves the right to change the size and configuration without prior notice.

ADDITIONAL EQUIPMENT

silencer OZA-GKK	inlet header OZA-VKO	flat adapter OZA-PEP	counter flange OZA-FOT	protective mesh OZA-SEM, OZA-SEB
check valve OZA-KLR	mounting support OZA-MOP	roof adapter OZA-PEK	weather protection hood OZA-ZNT	
grille OZA-R50	flexible connector OZA-COM	toroidal adapter OZA-PET	frequency converter ASC	straight section of the duct OZA-PUV
fan control cabinet SAU-PPV, SAU-SPV (up to 7.5 kW) separate cabinet for each motor				





OZA 300/301-056

Curve number	Number of poles	Nnom, kW	Impeller	α, deg	Current, A at 380V	Weight*, kg	
						casing type	
						01	02
1	2	4	A	50	8,4	48,3	46,3
2				52			
3				55			
4		5,5	I	50	11	58,4	56,4
5		7,5	B	50	14,7	81,4	79,4
6				52			
7				55			
8		11**	B	57	21	109	107
9				L			

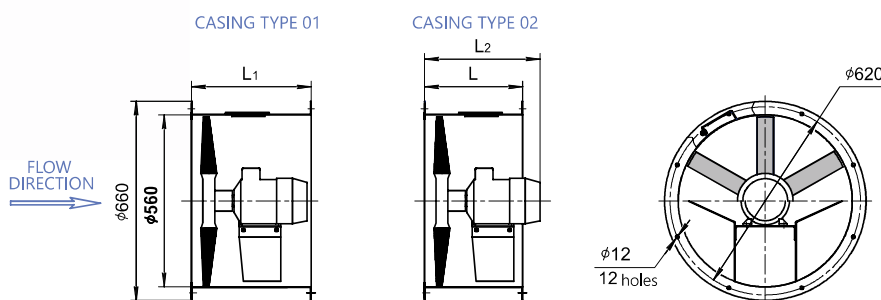
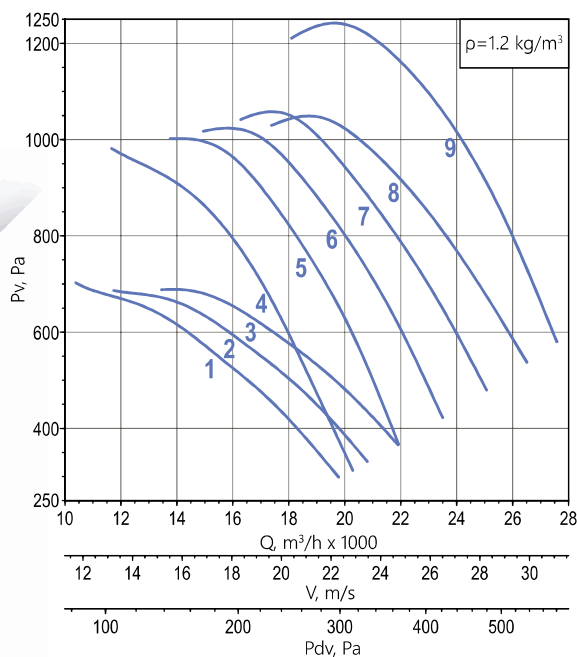

Motor size	L, mm	L1, mm	L2 max, mm
•100	420	510	510
•112 •132	515	625	625

NOTE:
 * Weight specified for OZA 300. When changing the motor type, the weight may change.
 ** "N" and "CR1" fan design only.
 The company reserves the right to change the size and configuration without prior notice.

ADDITIONAL EQUIPMENT

silencer OZA-GKK	inlet header OZA-VKO	flat adapter OZA-PEP	counter flange OZA-FOT	protective mesh OZA-SEM, OZA-SEB
check valve OZA-KLR	mounting support OZA-MOP	roof adapter OZA-PEK	weather protection hood OZA-ZNT	
grille OZA-R50	flexible connector OZA-COM	toroidal adapter OZA-PET	frequency converter ASC	straight section of the duct OZA-PUV

fan control cabinet
SAU-PPV, SAU-SPV
 (up to 7.5 kW) separate cabinet for each motor





OZA 300/301-063

Curve number	Number of poles	Nnom, kW	Impeller	α, deg	Current, A at 380V	Weight*, kg	
						casing type	
						01	02
1	6	0,37	B	55	1,31	35,7	34,2
2			B	57			
3		0,55	I	65	1,74	37	35,5
4				70			
5				65			
6		0,75	L	67	2,3	42,3	40,8
7				70			
		1,1	L	70	3,2	44,3	42,8

Curve number	Number of poles	Nnom, kW	Impeller	α, deg	Current, A at 380V	Weight, kg	
						casing type	
						01	02
1	4	0,37	A	45	1,18	31,4	29,4
2		0,55	A	47	1,5	34,4	32,9
3		0,75	A	50	2,2	35,9	34,4
4				52			
5		1,1	B	50	2,6	41,1	39,6
6				52			
7		1,5	B	55	3,6	43,1	41,6
8				57			
9		2,2	I	65	5,1	48,1	46,1
10				67			
11				70			
12				L			
13		3	L	67	7,3	51,8	49,8
14				70			

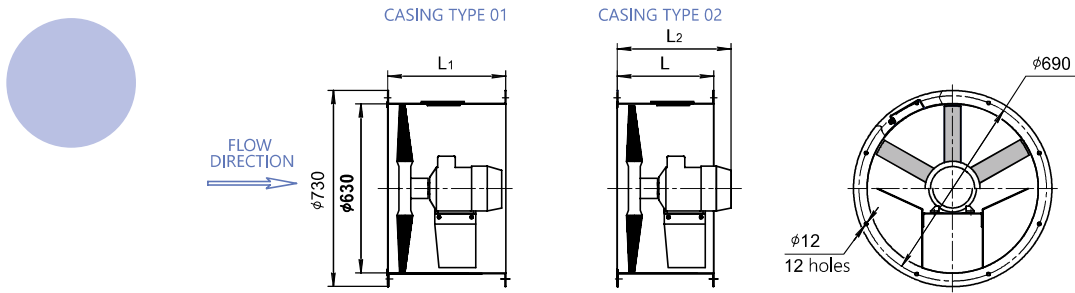
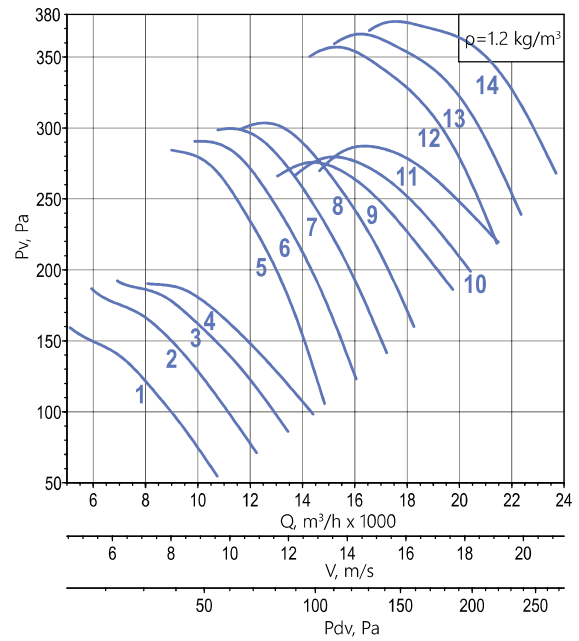
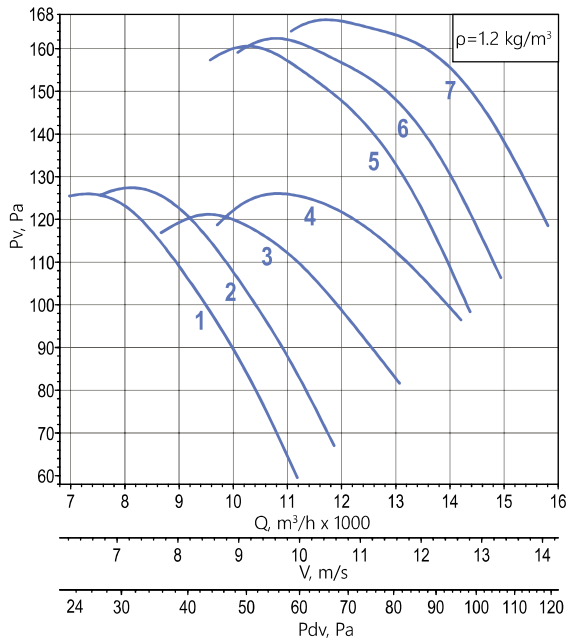

Motor size	L, mm	L1, mm	L2 max, mm
•63 •71 •80	370	440	440
•90 •100	420	510	510

NOTE:
 * Weight specified for OZA 300. When changing the motor type, the weight may change.
 The company reserves the right to change the size and configuration without prior notice.

ADDITIONAL EQUIPMENT

silencer OZA-GKK	inlet header OZA-VKO	flat adapter OZA-PEP	counter flange OZA-FOT	protective mesh OZA-SEM, OZA-SEB
check valve OZA-KLR	mounting support OZA-MOP	roof adapter OZA-PEK	weather protection hood OZA-ZNT	
grille OZA-R50	flexible connector OZA-COM	toroidal adapter OZA-PET	frequency converter ASC	straight section of the duct OZA-PUV

fan control cabinet
SAU-PPV, SAU-SPV

(up to 7.5 kW) separate cabinet for each motor





OZA 300/301-063

Curve number	Number of poles	Nnom, kW	Impeller	α , deg	Current, A at 380V	Weight*, kg	
						casing type	
						01	02
1	2	4	A	45	8,4	50,4	48,4
2				47			
3		5,5	Δ	50	11	59,4	57,4
4		7,5	A	52	14,7	80,4	78,4
5				55			
6		11**	B	50	21	109	107
7				52			
8				55			

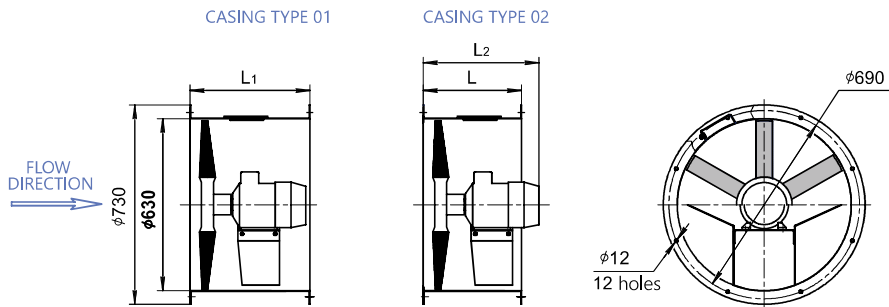
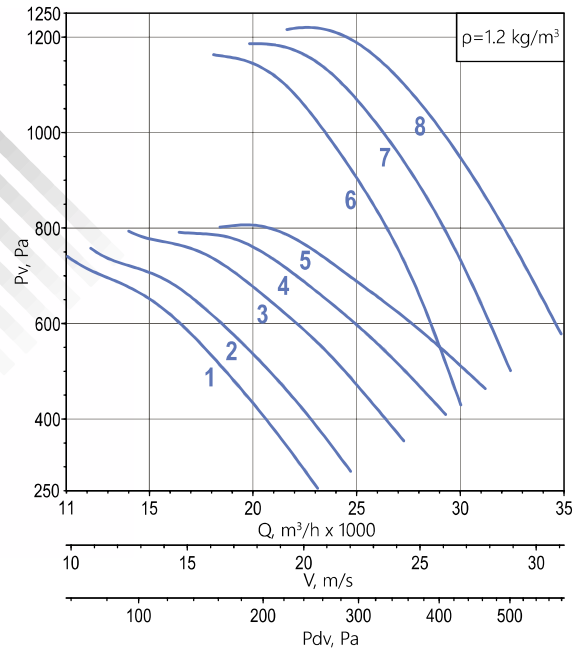

Motor size	L, mm	L1, mm	L2 max, mm
•100	420	510	510
•112 •132	515	625	625

NOTE:
 * Weight specified for OZA 300. When changing the motor type, the weight may change.
 ** "N" and "CR1" fan design only.
 The company reserves the right to change the size and configuration without prior notice.

ADDITIONAL EQUIPMENT				
silencer OZA-GKK	inlet header OZA-VKO	flat adapter OZA-PEP	counter flange OZA-FOT	protective mesh OZA-SEM, OZA-SEB
check valve OZA-KLR	mounting support OZA-MOP	roof adapter OZA-PEK	weather protection hood OZA-ZNT	
grille OZA-R50	flexible connector OZA-COM	toroidal adapter OZA-PET	frequency converter ASC	straight section of the duct OZA-PUV
fan control cabinet SAU-PPV, SAU-SPV (up to 7.5 kW) separate cabinet for each motor				





OZA 300/301-071

Curve number	Number of poles	Nnom, kW	Impeller	α, deg	Current, A at 380V	Weight*, kg	
						casing type	
						01	02
1	6	0,37	A	55	1,31	39,1	37,1
2				50			
3				52			
4		0,55	B	55	1,74	41,7	39,7
5				55			
6				57			
7		0,75	L	60	2,3	47,1	45,1
8				62			
9				65			
10		1,1	L	67	3,2	49,1	47,1
11				70			
	70						

Curve number	Number of poles	Nnom, kW	Impeller	α, deg	Current, A at 380V	Weight, kg	
						casing type	
						01	02
1	4	0,75	E	50	2,2	40,6	38,6
2		1,1	A	55	2,6	44,5	42,5
3		1,5	B	50	3,6	47,8	45,8
4		2,2	B	52	5,1	53,3	51,3
5				55			
6				55			
7		3	L	57	7,3	57,1	55,1
8				60			
9				62			
10		4	L	65	8,6	66,1	64,1
11				67			
12				70			

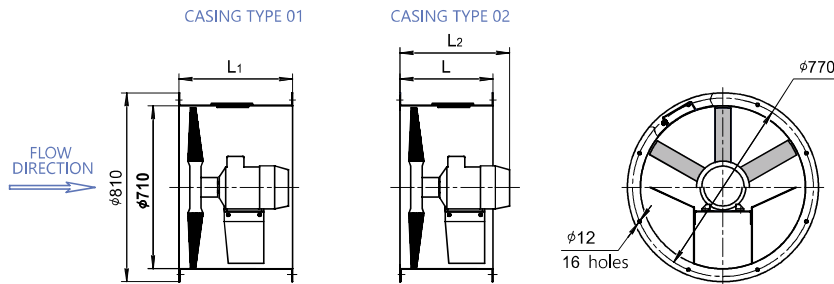
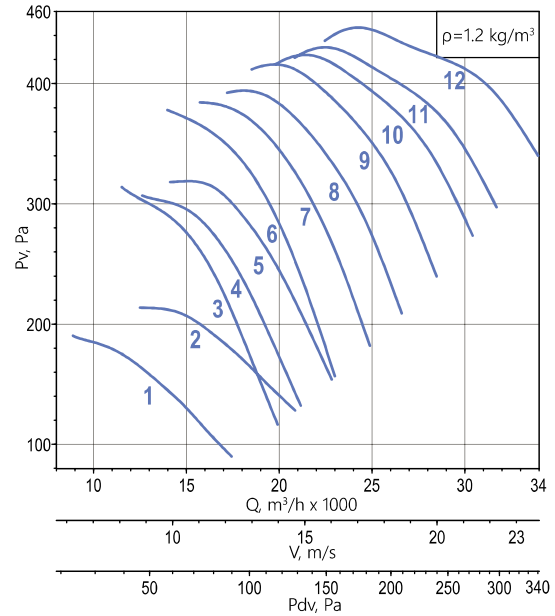
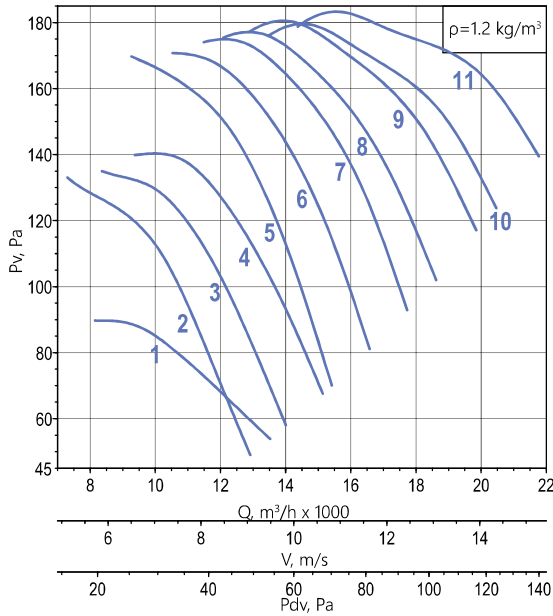

Motor size	L, mm	L1, mm	L2 max, mm
•71 •80	370	440	440
•90 •100	420	510	510
•112	515	625	625

NOTE:
 * Weight specified for OZA 300. When changing the motor type, the weight may change.
 The company reserves the right to change the size and configuration without prior notice.

ADDITIONAL EQUIPMENT

silencer OZA-GKK	inlet header OZA-VKO	flat adapter OZA-PEP	counter flange OZA-FOT	protective mesh OZA-SEM, OZA-SEB
check valve OZA-KLR	mounting support OZA-MOP	roof adapter OZA-PEK	weather protection hood OZA-ZNT	
grille OZA-R50	flexible connector OZA-COM	toroidal adapter OZA-PET	frequency converter ASC	straight section of the duct OZA-PUV
fan control cabinet SAU-PPV, SAU-SPV (up to 7.5 kW) separate cabinet for each motor				



OZA 301-071

Curve number	Number of poles	Nnom, kW	Impeller	α, deg	Current, A at 380V	Weight*, kg	
						casing type	
						01	02
1	2	5,5	E	50	11	64,6	62,6
2		7,5	E	52	14,7	89,6	87,1
3		11**	Δ	55	21	117	114
4		15**	I	52	30	161	154
5		18,5**	I	55	36	170	163
6				57			

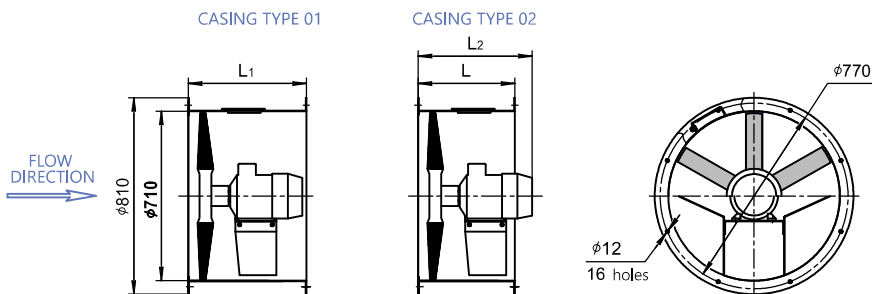
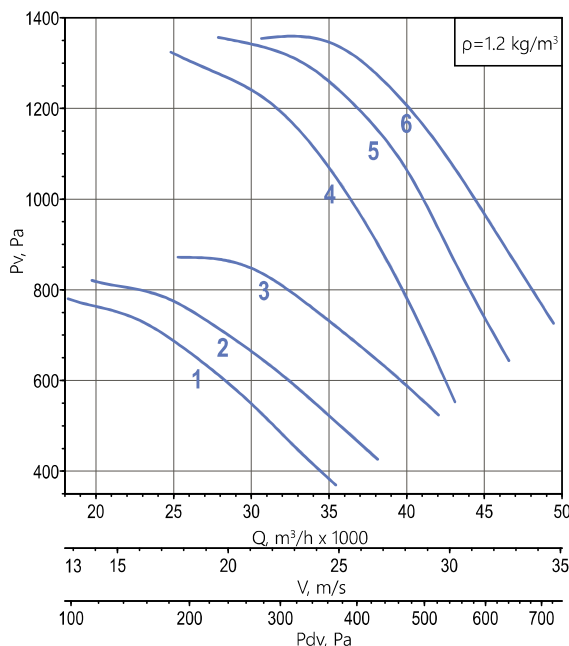
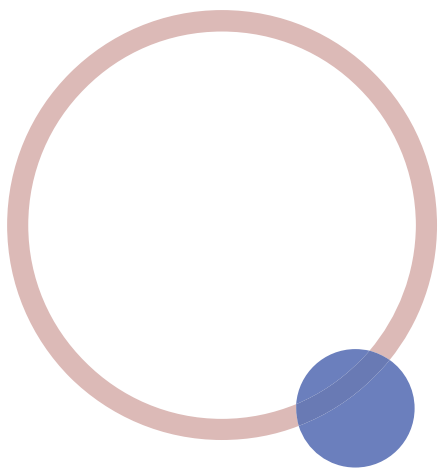

Motor size	L, mm	L1, mm	L2 max, mm
•100	420	510	510
•112 •132	515	625	625
•160	630	815	815

NOTE:
 * Weight specified for OZA 300. When changing the motor type, the weight may change.
 ** "N" and "CR1" fan design only.
 The company reserves the right to change the size and configuration without prior notice.

ADDITIONAL EQUIPMENT				
silencer OZA-GKK	inlet header OZA-VKO	flat adapter OZA-PEP	counter flange OZA-FOT	protective mesh OZA-SEM, OZA-SEB
check valve OZA-KLR	mounting support OZA-MOP	roof adapter OZA-PEK	weather protection hood OZA-ZNT	straight section of the duct OZA-PUV
grille OZA-R50	flexible connector OZA-COM	toroidal adapter OZA-PET	frequency converter ASC	
fan control cabinet SAU-PPV, SAU-SPV (up to 7.5 kW) separate cabinet for each motor				





OZA 300/301-080

Curve number	Number of poles	Nnom, kW	Impeller	α, deg	Current, A at 380V	Weight*, kg	
						casing type	
						01	02
1	8	1,1	L	67	3	71,5	68
2				70			
3		1,5	P	70	4,6	77	73,5

Curve number	Number of poles	Nnom, kW	Impeller	α, deg	Current, A at 380V	Weight, kg	
						casing type	
						01	02
1	6	0,37	A	50	1,31	51,2	47,2
2		A	55	1,74	52,5	48,5	
3		B	50	54	50		
4		L	50	2,3	59,5	55,5	
5		L	1,1	52	3,2	61,5	57,5
6				55			
7				57			
8		L	1,5	60	4,1	70	66,5
9				62			
10		L	2,2	65	5,8	78	74,5
11				67			
12		L	3	70	7	105	102
13				P			

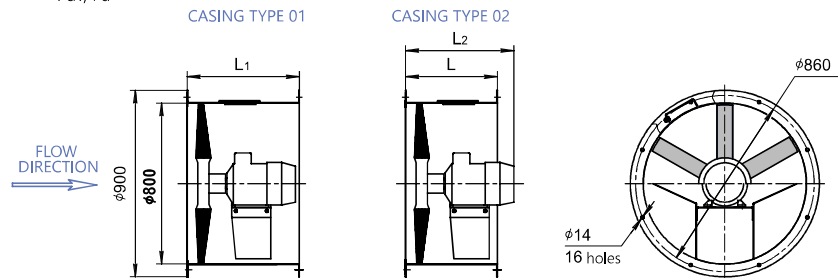
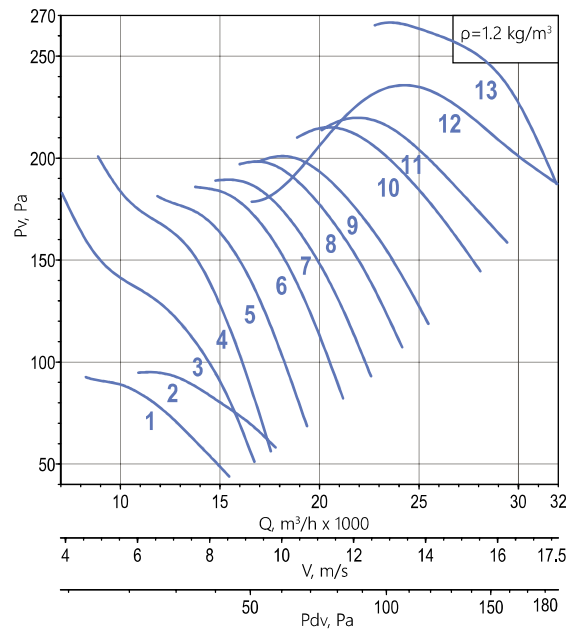
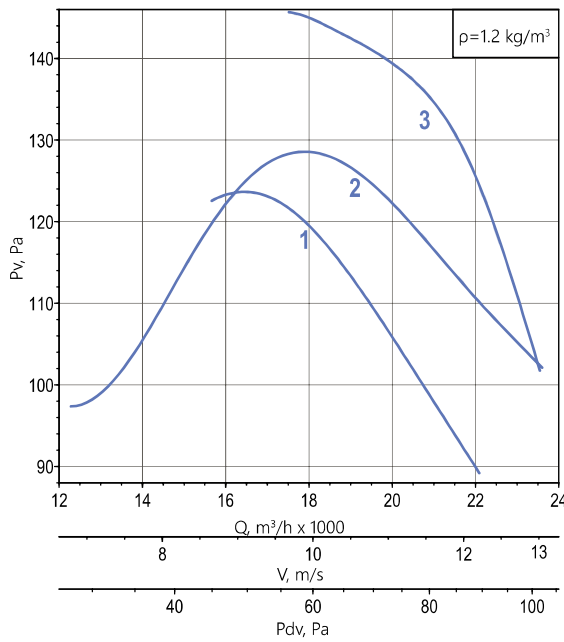
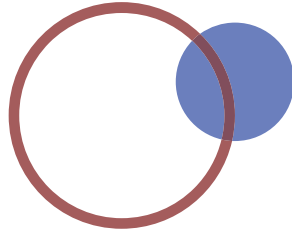

Motor size	L, mm	L1, mm	L2 max, mm
•71 •80	370	440	440
•90 •100	420	510	510
•112	515	625	625

NOTE:

* Weight specified for OZA 300. When changing the motor type, the weight may change. The company reserves the right to change the size and configuration without prior notice.

ADDITIONAL EQUIPMENT

silencer OZA-GKK	inlet header OZA-VKO	flat adapter OZA-PEP	counter flange OZA-FOT	protective mesh OZA-SEM, OZA-SEB
check valve OZA-KLR	mounting support OZA-MOP	roof adapter OZA-PEK	weather protection hood OZA-ZNT	
grille OZA-R50	flexible connector OZA-COM	toroidal adapter OZA-PET	frequency converter ASC	straight section of the duct OZA-PUV

fan control cabinet
SAU-PPV, SAU-SPV

(up to 7.5 kW) separate cabinet for each motor





OZA 300/301-080

Curve number	Number of poles	Nnom, kW	Impeller	α , deg	Current, A at 380V	Weight*, kg	
						casing type	
						01	02
1	4	1,5	A	50	3,6	58,6	54,6
2				55			
3		2,2	B	50	5,1	68,1	64,6
4				55			
5		3	L	50	7,3	72	68,5
6				52			
7		4	L	55	8,6	81	77,5
8				57			
9		5,5	L	60	11,7	111	108
10				62			
11				65			
12		7,5	L	67	15,6	135	132
13				70			
11		11	P	70	23	149	146

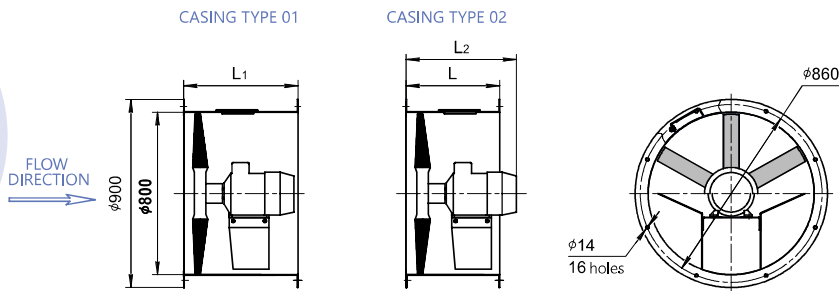
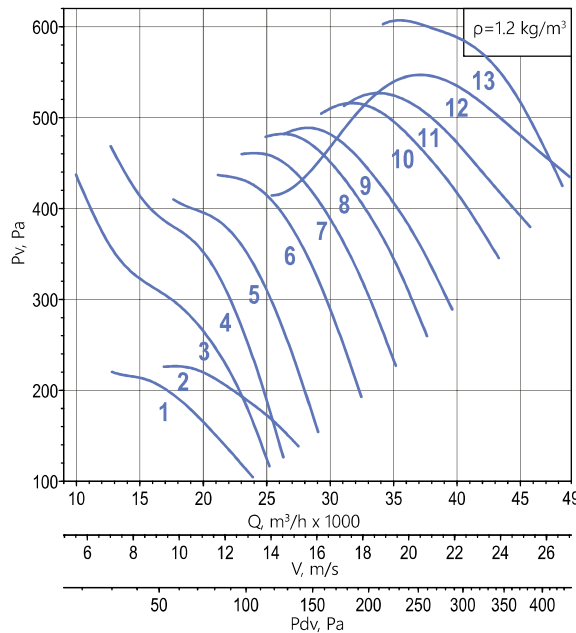

Motor size	L, mm	L1, mm	L2 max, mm
•80	370	440	440
•90 •100	420	510	510
•112 •132	515	625	625

NOTE:

* Weight specified for OZA 300. When changing the motor type, the weight may change. The company reserves the right to change the size and configuration without prior notice.

ADDITIONAL EQUIPMENT

silencer OZA-GKK	inlet header OZA-VKO	flat adapter OZA-PEP	counter flange OZA-FOT	protective mesh OZA-SEM, OZA-SEB
check valve OZA-KLR	mounting support OZA-MOP	roof adapter OZA-PEK	weather protection hood OZA-ZNT	
grille OZA-R50	flexible connector OZA-COM	toroidal adapter OZA-PET	frequency converter ASC	straight section of the duct OZA-PUV

fan control cabinet
SAU-PPV, SAU-SPV
(up to 7.5 kW) separate cabinet for each motor





OZA 300/301-090

Curve number	Number of poles	Nnom, kW	Impeller	α, deg	Current, A at 380V	Weight*, kg	
						casing type	
						01	02
1	8	1,1	L	60	3	78,8	72,8
2				62			
3				65			
4		1,5	L	67	4,6	82,3	76,3
5				70			
6				70			
6	2,2	P	70	6,3	103	96,2	

Curve number	Number of poles	Nnom, kW	Impeller	α, deg	Current, A at 380V	Weight, kg	
						casing type	
						01	02
1	6	0,75	A	55	2,3	62,7	58,2
2		1,1	B	50	3,2	66,8	62,3
3				52			
4				52			
5		1,5	L	55	4,1	77,3	71,3
6		2,2	L	57	5,8	85,3	79,3
7				60			
8				62			
9		3	L	65	7	112	105
10		4	L	67	9	121	114
11				70			
12				70			
12	5,5	P	70	12	147	140	

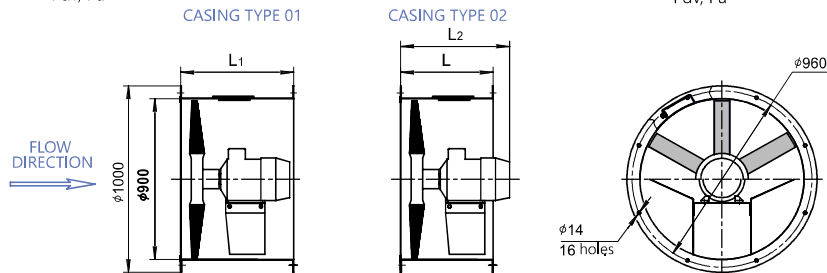
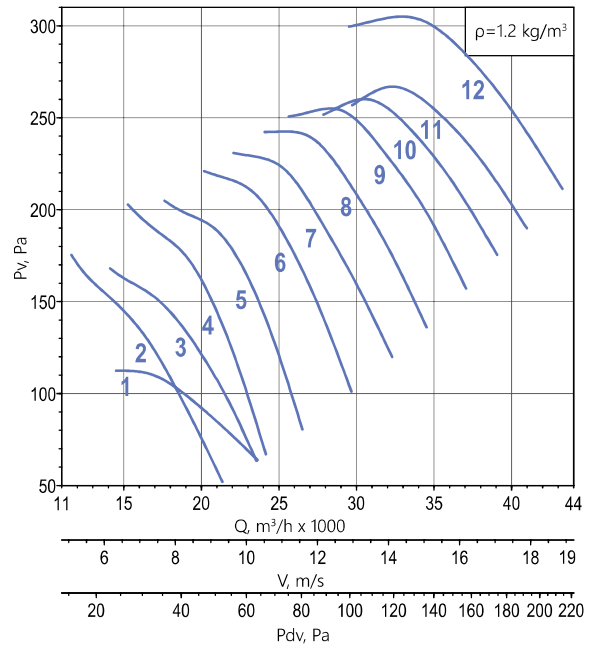
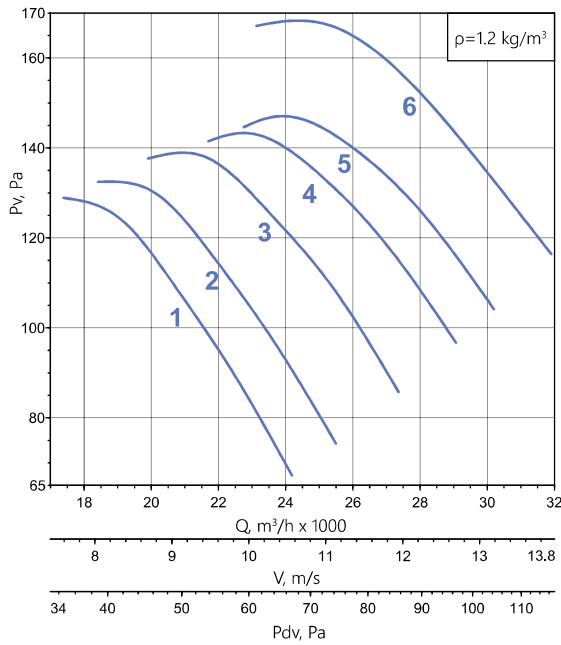

Motor size	L, mm	L1, mm	L2 max, mm
•80	370	440	440
•90 •100	420	510	510
•112 •132	515	625	625

NOTE:
 * Weight specified for OZA 300. When changing the motor type, the weight may change.
 The company reserves the right to change the size and configuration without prior notice.

ADDITIONAL EQUIPMENT

silencer OZA-GKK	inlet header OZA-VKO	flat adapter OZA-PEP	counter flange OZA-FOT	protective mesh OZA-SEM, OZA-SEB
check valve OZA-KLR	mounting support OZA-MOP	roof adapter OZA-PEK	weather protection hood OZA-ZNT	
grille OZA-R50	flexible connector OZA-COM	toroidal adapter OZA-PET	frequency converter ASC	straight section of the duct OZA-PUV
fan control cabinet SAU-PPV, SAU-SPV (up to 7.5 kW) separate cabinet for each motor				





OZA 300/301-090

Curve number	Number of poles	Nnom, kW	Impeller	α , deg	Current, A at 380V	Weight*, kg	
						casing type	
						01	02
1	4	2,2	A	50	5,1	72,7	66,7
2				55			
3		3	B	50	7,3	77,3	71,3
4		4		52	8,6	86,3	80,3
5		5,5	L	52	11,7	118	111
6		55					
7		7,5	L	57	15,6	142	135
8				60			
9				62			
10		11	L	65	23	154	147
11				67			
12				70			
13		15	L	70	31	203	191
	18,5	P	70	36	224	211	

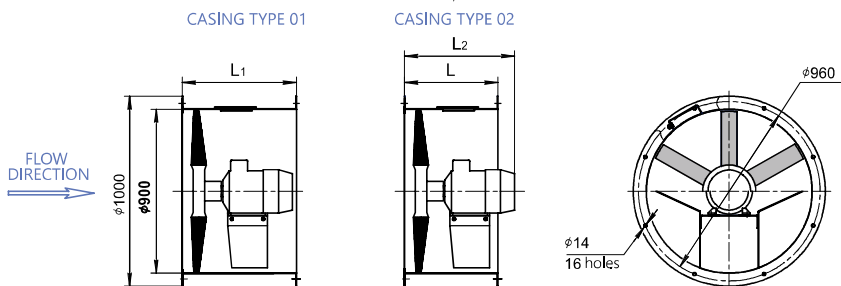
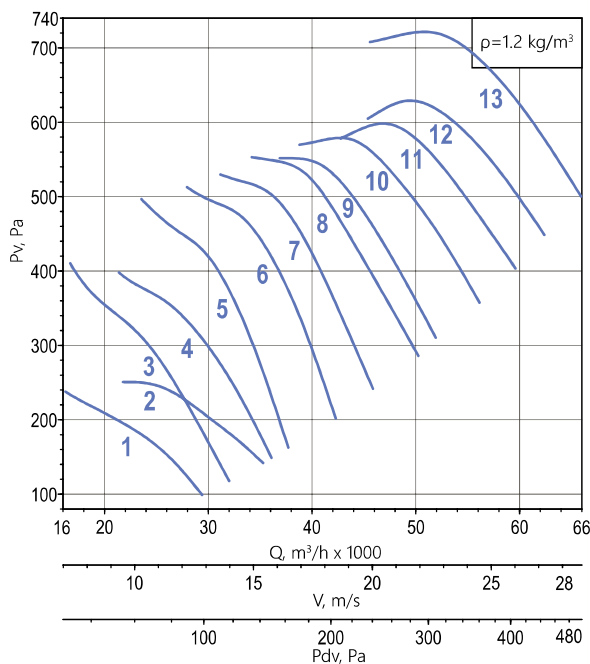

Motor size	L, mm	L1, mm	L2 max, mm
•90 •100	420	510	510
•112 •132	515	625	625
•160	630	815	815

NOTE:
 * Weight specified for OZA 300. When changing the motor type, the weight may change.
 The company reserves the right to change the size and configuration without prior notice.

ADDITIONAL EQUIPMENT				
silencer OZA-GKK	inlet header OZA-VKO	flat adapter OZA-PEP	counter flange OZA-FOT	protective mesh OZA-SEM, OZA-SEB
check valve OZA-KLR	mounting support OZA-MOP	roof adapter OZA-PEK	weather protection hood OZA-ZNT	
grille OZA-R50	flexible connector OZA-COM	toroidal adapter OZA-PET	frequency converter ASC	straight section of the duct OZA-PUV
fan control cabinet SAU-PPV, SAU-SPV (up to 7.5 kW) separate cabinet for each motor				





OZA 300/301-100

Curve number	Number of poles	Nnom, kW	Impeller	α, deg	Current, A at 380V	Weight*, kg	
						casing type	
						01	02
1	8	1,1	B	57	3	83,6	76,6
2				60			
3				60			
4		1,5	L	62	4,6	89,3	82,3
5				65			
6				67			
7		2,2	D	70	6,3	107	99,4
8				67			
9				70			
	3	P	67	8	116	108	
			67				
			70				

Curve number	Number of poles	Nnom, kW	Impeller	α, deg	Current, A at 380V	Weight, kg	
						casing type	
						01	02
1	6	1,1	B	50	3,2	77,5	72,6
2				52			
3				55			
4		1,5	B	57	4,1	82,1	75,1
5				60			
6				60			
7		2,2	B	62	5,8	90,1	83,1
8				65			
9				67			
10		3	L	60	7	119	111
11				62			
12				65			
13		4	D	67	9	128	120
	67						
	70						
	5,5	D	67	12	151	143	
			70				
			67				
	7,5	P	67	17,5	169	161	
			70				
			70				
	11	T	70	24	214	210	
			70				

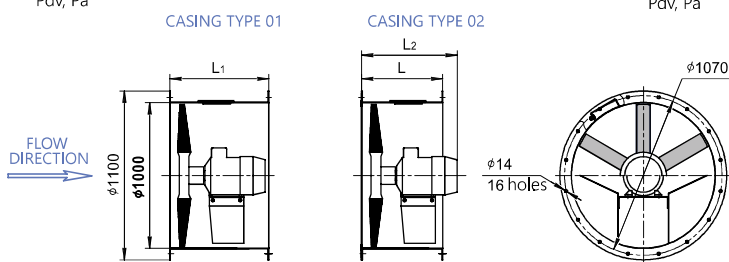
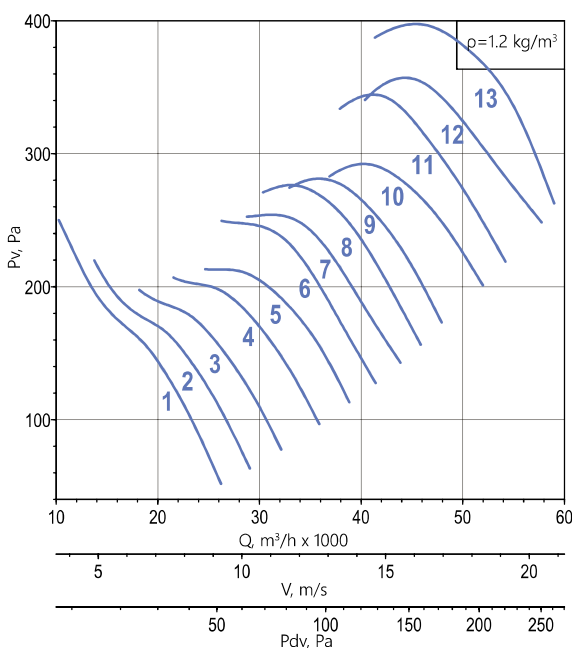
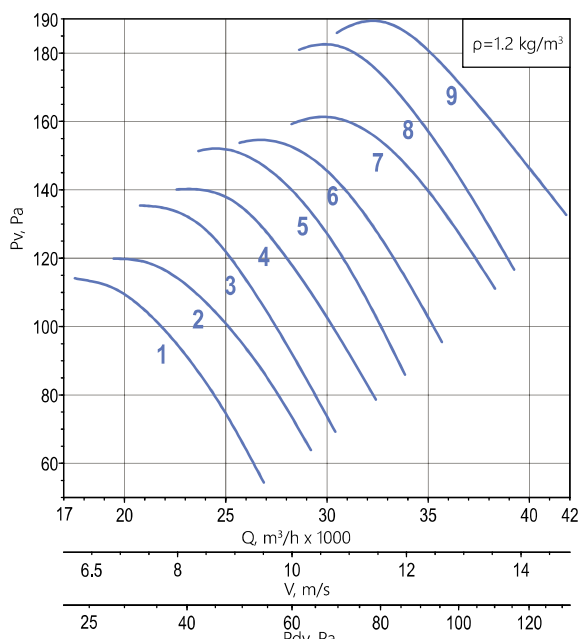

Motor size	L, mm	L1, mm	L2 max, mm
•80	370	440	440
•90 •100	420	510	510
•112 •132	515	625	625
•160	630	815	815

NOTE:
 * Weight specified for OZA 300. When changing the motor type, the weight may change.
 The company reserves the right to change the size and configuration without prior notice.

ADDITIONAL EQUIPMENT

silencer OZA-GKK	inlet header OZA-VKO	flat adapter OZA-PEP	counter flange OZA-FOT	protective mesh OZA-SEM, OZA-SEB
check valve OZA-KLR	mounting support OZA-MOP	roof adapter OZA-PEK	weather protection hood OZA-ZNT	
grille OZA-R50	flexible connector OZA-COM	toroidal adapter OZA-PET	frequency converter ASC	straight section of the duct OZA-PUV

fan control cabinet
SAU-PPV, SAU-SPV

(up to 7.5 kW) separate cabinet for each motor





OZA 300/301-100

Curve number	Number of poles	Nnom, kW	Impeller	α , deg	Current, A at 380V	Weight*, kg	
						casing type	
						01	02
1	4	2,2	B	45	5,1	81,6	74,6
2		3	B	48	7,3	84,1	77,1
3		4	B	50	8,6	93,1	86,1
4		5,5	B	52	11,7	123	115
5				55			
6		7,5	B	57	15,6	147	139
7		11	B	60	23	159	151
8				L			
9		15	L	62	31	213	199
10				D			
11		18,5	D	67	36	231	217
12				70			
13		22	P	67	44	253	239
14		30	P	70	56	286	272

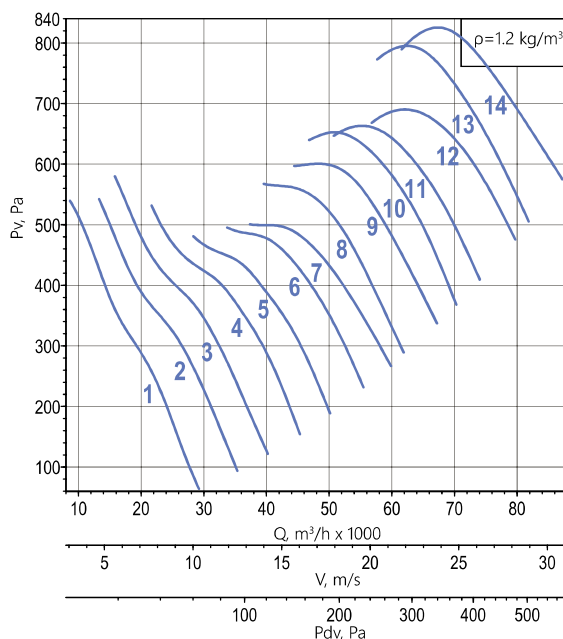

CASING TYPE 01

CASING TYPE 02

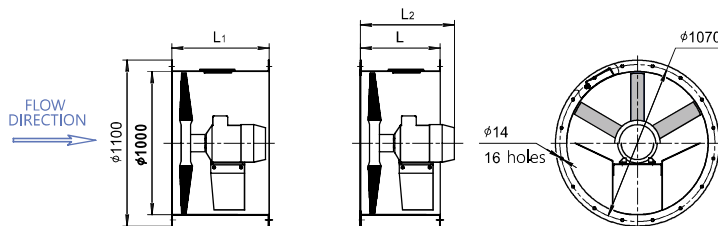

Motor size	L, mm	L1, mm	L2 max, mm
•90 •100	420	510	510
•112 •132	515	625	625
•160 •180	630	815	815

NOTE:
 * Weight specified for OZA 300. When changing the motor type, the weight may change.
 The company reserves the right to change the size and configuration without prior notice.

ADDITIONAL EQUIPMENT

silencer OZA-GKK	inlet header OZA-VKO	flat adapter OZA-PEP	counter flange OZA-FOT	protective mesh OZA-SEM, OZA-SEB
check valve OZA-KLR	mounting support OZA-MOP	roof adapter OZA-PEK	weather protection hood OZA-ZNT	
grille OZA-R50	flexible connector OZA-COM	toroidal adapter OZA-PET	frequency converter ASC	straight section of the duct OZA-PUV
fan control cabinet SAU-PPV, SAU-SPV (up to 7.5 kW) separate cabinet for each motor				





OZA 300/301-112

Curve number	Number of poles	Nnom, kW	Impeller	α, deg	Current, A at 380V	Weight*, kg	
						casing type	
						01	02
1	8	1,1	G	52	3	94	86,5
2			M	52		97,5	90,5
3		1,5	M	55	4,6	97	89,5
4				57			
5		2,2	M	60	6,3	108	109
6				60			
7		3	D	62	8	123	114
8				65			
9		67	70	70	10,5	136	127
10							
11		P	70	139	130		
12		5,5	T	67	13,6	153	144
13		7,5	T	70	18	237	222

Curve number	Number of poles	Nnom, kW	Impeller	α, deg	Current, A at 380V	Weight, kg	
						casing type	
						01	02
1	6	2,2	G	52	5,8	96	88,5
2		3	M	52	7	130	121
3		4	M	55	9	139	130
4				57			
5		5,5	M	60	12	162	153
6				D			
7		7,5	D	62	17,5	176	167
8				65			
9		11	D	67	24	230	215
10				70			
11		P	70	233	218		
12		15	T	67	32	262	247
13				70			

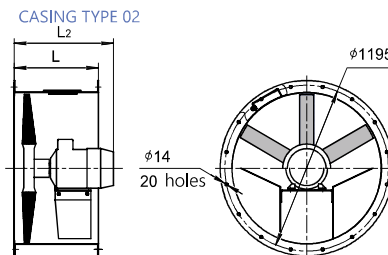
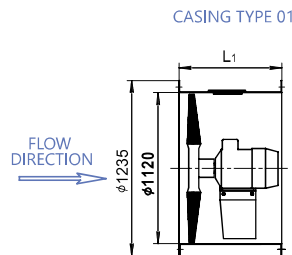
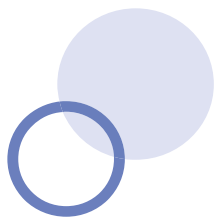
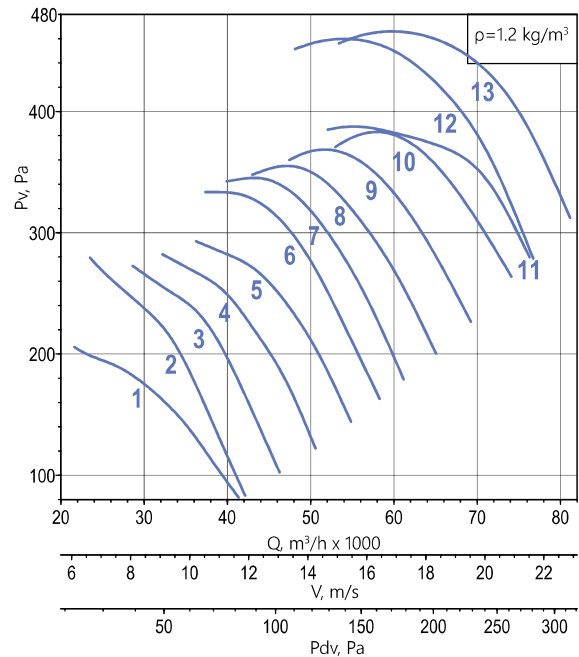
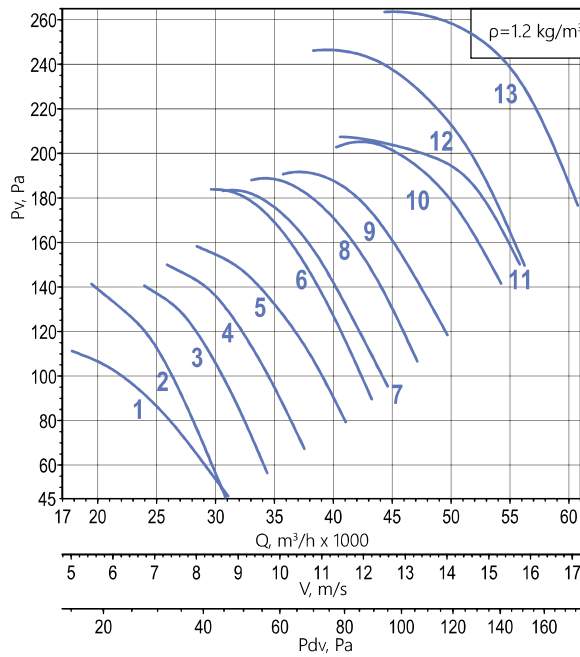

Motor size	L, mm	L1, mm	L2 max, mm
·90 ·100	420	510	510
·112 ·132	515	625	625
·160	630	815	815

NOTE:

* Weight specified for OZA 300. When changing the motor type, the weight may change. The company reserves the right to change the size and configuration without prior notice.

ADDITIONAL EQUIPMENT

silencer OZA-GKK	inlet header OZA-VKO	flat adapter OZA-PEP	counter flange OZA-FOT	protective mesh OZA-SEM, OZA-SEB
check valve OZA-KLR	mounting support OZA-MOP	roof adapter OZA-PEK	weather protection hood OZA-ZNT	
grille OZA-R50	flexible connector OZA-COM	toroidal adapter OZA-PET	frequency converter ASC	straight section of the duct OZA-PUV
fan control cabinet SAU-PPV, SAU-SPV (up to 7.5 kW) separate cabinet for each motor				





OZA 300/301-112

Curve number	Number of poles	Nnom, kW	Impeller	α, deg	Current, A at 380V	Weight*, kg		
						casing type		
						01	02	
1	4	4	G	45	8,6	99	91,5	
2		5,5	G	47	11,7	132	123	
3		7,5	G	50	15,6	156	147	
4		11	M	52	23	168	159	
5		15	M	55	31	226	211	
6		18,5	M	57	36	244	229	
7		22	D	60	44	262	247	
8		30	D	62	56	295	280	
9		37	D	65	70	354	343	
10		45	P	70	86	357	346	
11			T	67		391	380	
12								
13								
14								
15								

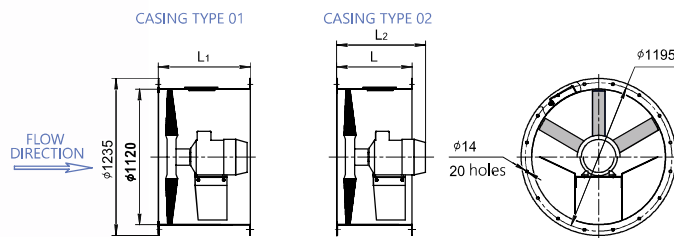
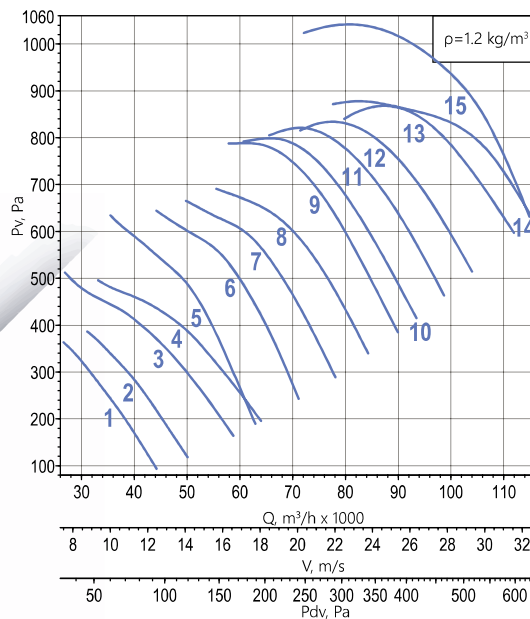

Motor size	L, mm	L1, mm	L2 max, mm
•100	420	510	510
•112 •132	515	625	625
•160 •180	630	815	815
•200	820	950	950

NOTE:

* Weight specified for OZA 300. When changing the motor type, the weight may change. The company reserves the right to change the size and configuration without prior notice.

ADDITIONAL EQUIPMENT

silencer OZA-GKK	inlet header OZA-VKO	flat adapter OZA-PEP	counter flange OZA-FOT	protective mesh OZA-SEM, OZA-SEB
check valve OZA-KLR	mounting support OZA-MOP	roof adapter OZA-PEK	weather protection hood OZA-ZNT	
grille OZA-R50	flexible connector OZA-COM	toroidal adapter OZA-PET	frequency converter ASC	straight section of the duct OZA-PUV

fan control cabinet
SAU-PPV, SAU-SPV
(up to 7.5 kW) separate cabinet for each motor





OZA 301-125

Curve number	Number of poles	Nnom, kW	Impeller	α, deg	Current, A at 380V	Weight*, kg	
						casing type	
						01	02
1	8	1,5	R	50	4,6	105	96
2						130	119
3							
4		2,2	C	50	6,3	130	119
5							
6							
7		3	C	55	8	136	125
8							
9							
6	4	C	60	10,5	149	138	
7							
8							
8	5,5	T	60	13,6	162	151	
9							
9	7,5	T	70	18	248	231	

Curve number	Number of poles	Nnom, kW	Impeller	α, deg	Current, A at 380V	Weight, kg	
						casing type	
						01	02
1	6	4	R	50	9	148	137
2						174	163
3							
4		5,5	C	50	12	174	163
5							
6							
7		7,5	C	55	17,5	189	178
8							
9							
6		11	C	60	24	245	228
7							
8	15	T	60	32	248	231	
9							
10							
9	15	T	62	32	268	251	
10							
10	18,5	T	67	37	282	266	

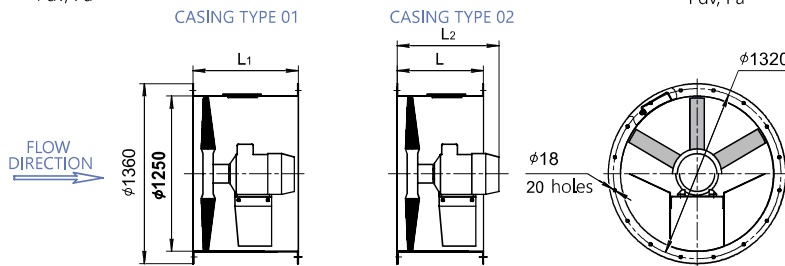
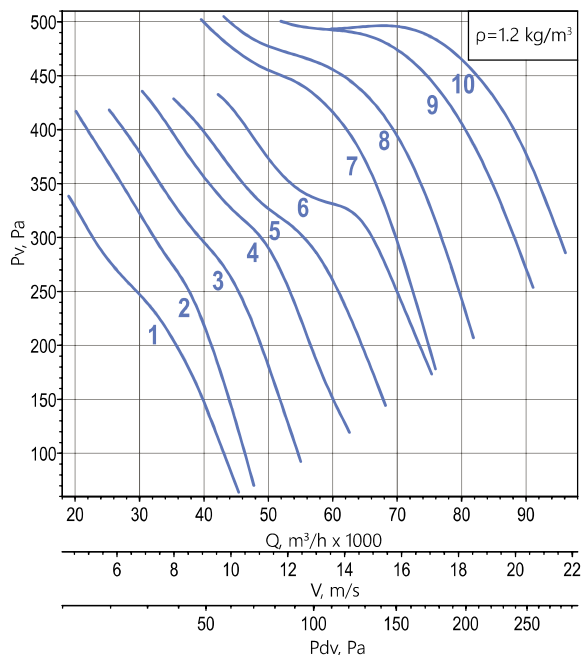
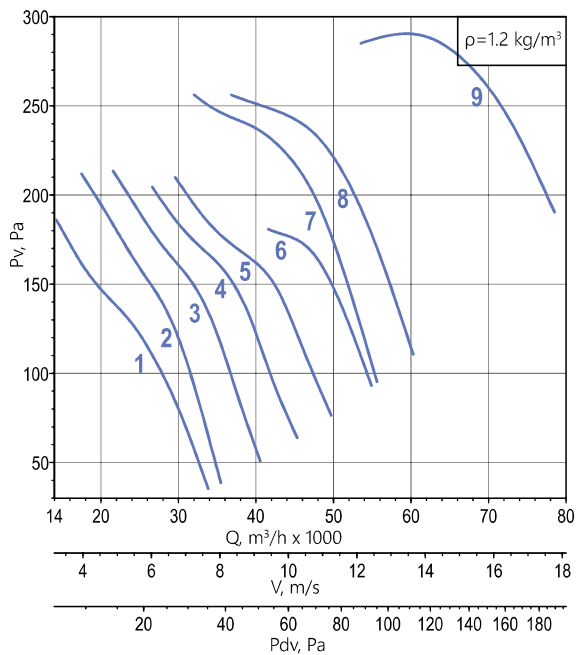

Motor size	L, mm	L1, mm	L2 max, mm
•100	420	510	510
•112 •132	515	625	625
•160 •180	630	815	815

NOTE:

* Weight specified for OZA 300. When changing the motor type, the weight may change. The company reserves the right to change the size and configuration without prior notice.

ADDITIONAL EQUIPMENT

silencer OZA-GKK	inlet header OZA-VKO	flat adapter OZA-PEP	counter flange OZA-FOT	protective mesh OZA-SEM, OZA-SEB
check valve OZA-KLR	mounting support OZA-MOP	roof adapter OZA-PEK	weather protection hood OZA-ZNT	
grille OZA-R50	flexible connector OZA-COM	toroidal adapter OZA-PET	frequency converter ASC	straight section of the duct OZA-PUV
fan control cabinet SAU-PPV, SAU-SPV (up to 7.5 kW) separate cabinet for each motor				





OZA-300/301-125

Curve number	Number of poles	Nnom, kW	Impeller	α , deg	Current, A at 380V	Weight*, kg	
						casing type	
						01	02
1	4	11	R	50	23	181	170
2		15	C	50	31	240	223
3		18,5	C	52	36	258	241
4		22	C	55	44	277	260
5		30	C	57	56	310	293
6				60			
7		37	T	60	70	376	364
8		45	T	62	86	406	394

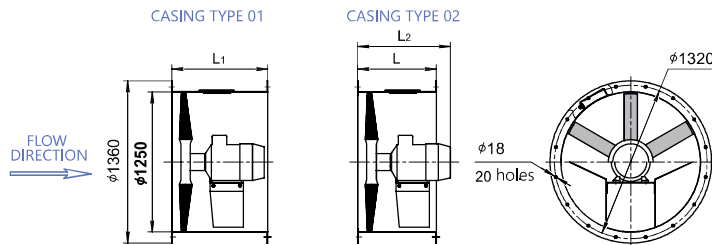
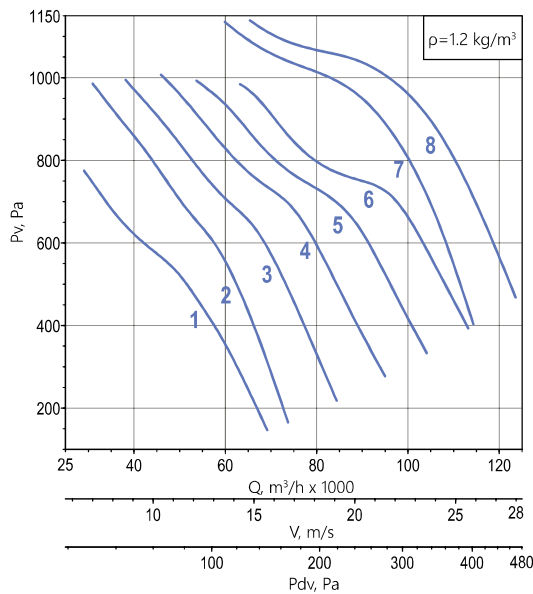

Motor size	L, mm	L1, mm	L2 max, mm
•132	515	625	625
•160 •180	630	815	815
•200	820	950	950

NOTE:
 * Weight specified for OZA 300. When changing the motor type, the weight may change.
 The company reserves the right to change the size and configuration without prior notice.

ADDITIONAL EQUIPMENT

silencer OZA-GKK	inlet header OZA-VKO	flat adapter OZA-PEP	counter flange OZA-FOT	protective mesh OZA-SEM, OZA-SEB
check valve OZA-KLR	mounting support OZA-MOP	roof adapter OZA-PEK	weather protection hood OZA-ZNT	straight section of the duct OZA-PUV
grille OZA-R50	flexible connector OZA-COM	toroidal adapter OZA-PET	frequency converter ASC	
fan control cabinet SAU-PPV, SAU-SPV (up to 7.5 kW) separate cabinet for each motor				





QUESTIONNAIRE

PLEASE FILL IN ALL THE NECESSARY DATA AND SEND IT TO THE NEAREST COMPANY OFFICE

AXIAL FAN

OZA 300 _____

OZA 301 _____

Quantity, pcs: _____

Contact person: _____

Organization: _____

Tel.: _____

e-mail: _____

City: _____

PLEASE CHECK OR SPECIFY THE REQUIRED VALUE

operation mode	efficiency Q, m ³ /h	total pressure P _v	
	pressure at t=20° C, Pa	static pressure P _{sv}	
fan size			
design fan	N – general purpose industrial		
	V – explosion-proof		
	CR1 – corrosion-resistant		
	VCR1 – corrosion-resistant explosion-proof		
climatic version	Y1 (Y1)		
	Y2 (Y2)		
	YHL1 (YXЛ1)		
motor	nominal power, kW		
	number of poles		
casing type	long case - 01		
	short case - 02		

Additional information

OZA-GKK silence			
OZA-KLR universal check valve			
OZA-VKO inlet header			
mounting support	OZA-MOP		
	OZA-MOB		
OZA-COM flexible connector	series		
	flange material	stainless steel	
		galvanized steel	
OZA-PEP flat adapter			
OZA-PET toroidal adapter			
OZA-PEK roof adapter			
OZA-PUV straight section of the air duct			
OZA-R50 grille			
protective mesh	OZA-SEM		
	OZA-SEB		
OZA-FOT counter flange			
OZA-ZNT weather protection hood			
FC-051 frequency converter			
SAU-PPV, SAU-SPV fan control cabinet			

Additional conditions:

Customer _____
(signature)

_____ (full name)





HIGH-PRESSURE AXIAL FANS

OZA-F 300, OZA-F 301

Low-and medium-pressure axial fans of the OZA-300, OZA-301 series consist of a new design impeller, an all-welded casing made of rolled sheet and an asynchronous motor located in the casing. Thanks to its special aerodynamic shape, the motor support stand serves as a guide apparatus.

- ▶ ventilation and air heating systems;
- ▶ sanitary and technological installations;
- ▶ positive pressure ventilation systems (PD-systems).



•040 •045 •050 •056 •063 •071 •080 •090 •100 •112 •125

THIS SERIES COMPLEMENTS THE OZA-300, OZA-301 SERIES AND IS DISTINGUISHED BY A HIGHER DEVELOPED PRESSURE

Low-and medium-pressure axial fans of the OZA-F 300, OZA-F 301 series consist of a new design impeller, an all-welded casing made of rolled sheet and an asynchronous motor located in the casing. Thanks to its special aerodynamic shape, the motor support stand serves as a guide apparatus.

The impeller is made with variable-incidence blades, the setting angle of the blade is adjustable for maximum efficiency. The volumetric blades are made by using injection molding. The air flow cross-section is maximized, which gives a significant reduction in the outlet speed. Thanks to the new impeller design, the fans are designed with the highest static efficiency.

The flanges of the fan casing are edge-raised, providing increased rigidity and precision, and ensuring the same minimum radial clearance between the impeller blades and the casing along the perimeter of the impeller.

The casing is made of stainless or carbon steel.

Motor ingress protection rating IP54.

If there is no network at the inlet, it is necessary to use the OZA-VKO inlet header or the OZA-PET toroidal adapter.

The flow direction is always from the impeller to the motor, regardless of orientation. All elements of the fan casing feature a protective and decorative paint coating.

Additional equipment options are available - see the "Additional equipment" catalog.

- ▶ general purpose industrial (N);
- ▶ corrosion-resistant (CR1);
- ▶ explosion-proof (V);
- ▶ explosion-proof corrosion-resistant (CRV1).

OPERATING CONDITIONS:

- ▶ ambient temperature
 - від -40° C до +40° C (OZA-F 300, OZA-F 301);
 - від -60° C до +40° C (OZA-F 300).
- ▶ the average value of vibration velocity of external vibration sources at the fan installation locations is no more than 2 mm/s;
- ▶ conditions for the air mixture to be moved are presented in the table "Conditions for the air mixture to be moved".



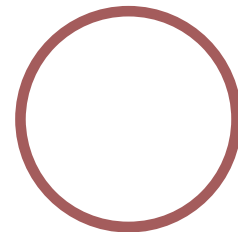

EXAMPLE:

OZA-F 300 axial fan, size 080/L, impeller blade angle 50°, general purpose industrial design, nominal motor power $N_{nom} = 0.75$ kW, number of poles 6, climatic version Y2, casing type 02

OZA-F 301-080/L-50-N-00075/6-Y1

- ▶ energy efficient axial fan (•OZA-F 300 •OZA-F 301 (lightweight impeller))
- ▶ fan size (•040 •045 •050 •056 •063 •071 •080 •090 •100 •112 •125)
- ▶ impeller modification (•A •B •C •D •E •I •L •M •P •R •S •T)
- ▶ impeller blade angle α , deg (•40... •70)
- ▶ design (•N •CR1 •V •VCR1)
- ▶ motor parameters²: •I/P
 - I³ - Motor Power Index - see Table 1
 - P - number of poles: 2 (3000 rpm) 4 (1500 rpm) 6 (1000 rpm) 8 (750 rpm)
- ▶ climatic version •Y1 •Y2 •YHL1 (OZA 300 only)

NOTE:

¹The lightweight impeller design is used for less demanding tasks (clean air without impurities) and is not used in explosion-proof version.
² By default all supplied motors are designed for 380V, 50Hz, direct start. Design types of other voltages and connection methods are available upon special agreement.
³The Motor Power Index is shown in the Table.
 Special requirements for the fan are specified additionally and agreed upon with the manufacturer.

OZA-F MOTOR POWER INDEX

Nominal power (N_{nom}), kW	0,18...0,75	1,1...7,5	11...90
Motor Power Index (I)	00018...00075	00110...00750	01100...09000



OZA-F 300/301-040

Curve number	Number of poles	Motor size	Total power Nsum, kW	Impeller	α , deg	Current, A at 380V	Weight*, kg	Curve number	Number of poles	Motor size	Total power Nsum, kW	Impeller	α , deg	Current, A at 380V	Weight, kg
1	4	56	0,24 (2x0,12)**	A	50	1,0	42,6	2	2	71	1,5 (2x0,75)	A	50	3,8	55,8
2		63	0,5 (2x0,25)	B	50	1,64	42,6	3		90	6 (2x3,0)	B	60	13	82,8

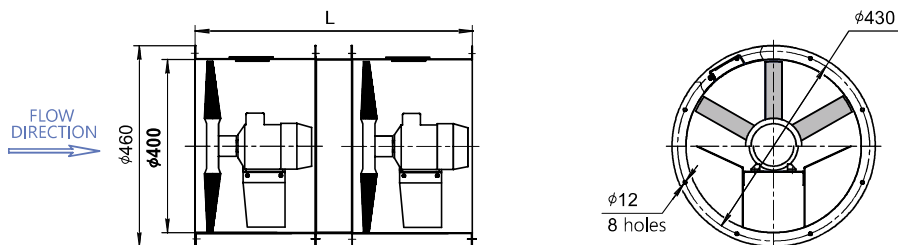
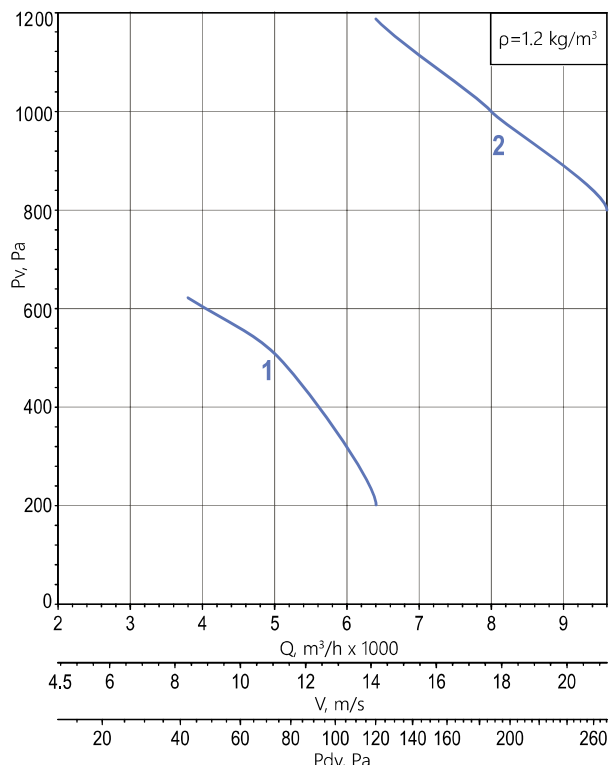
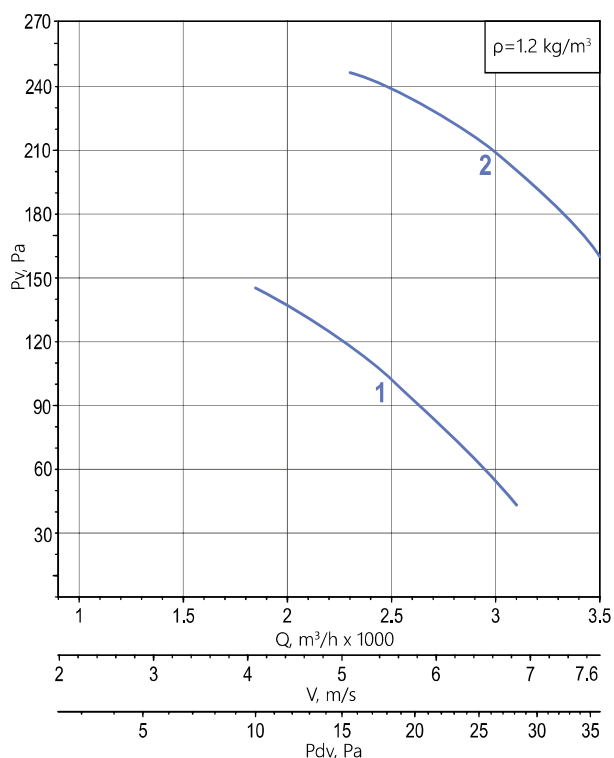

Motor size	L, mm
-56	810
-63	910
-71	1030
-90	1070

NOTE:
 * Weight specified for OZA-F 300. When changing the motor type, the weight may change.
 ** "N" and "CR1" fan design only.
 The company reserves the right to change the size and configuration without prior notice.

ADDITIONAL EQUIPMENT

silencer OZA-GKK	inlet header OZA-VKO	flat adapter OZA-PEP	counter flange OZA-FOT	protective mesh OZA-SEM, OZA-SEB
check valve OZA-KLR	mounting support OZA-MOP	roof adapter OZA-PEK	weather protection hood OZA-ZNT	straight section of the duct OZA-PUV
grille OZA-R50	flexible connector OZA-COM	toroidal adapter OZA-PET	frequency converter ASC	
fan control cabinet SAU-PPV, SAU-SPV (up to 7.5 kW) separate cabinet for each motor				



OZA-F 300/301-045

Curve number	Number of poles	Motor size	Total power Nsum, kW	Impeller	α , deg	Current, A at 380V	Weight*, kg
1	4	63	0,74 (2x0,37)	B	52	2,24	51,9
2		71	1,1 (2x0,55)		60	2,8	61,7

Curve number	Number of poles	Motor size	Total power Nsum, kW	Impeller	α , deg	Current, A at 380V	Weight, kg
1	2	71	2,2 (2x1,1)	A	45	5,4	63,1
2		80	4,4 (2x2,2)		52	10	72,1
3		100	8 (2x4,0)	B	52	16,8	91,9
4		100	8 (2x4,0)		60	16,8	92,5

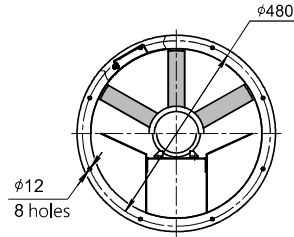
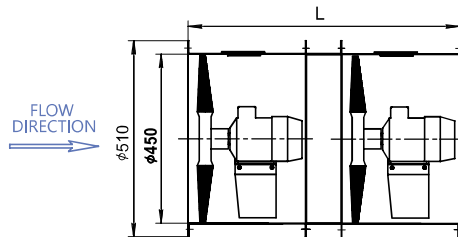
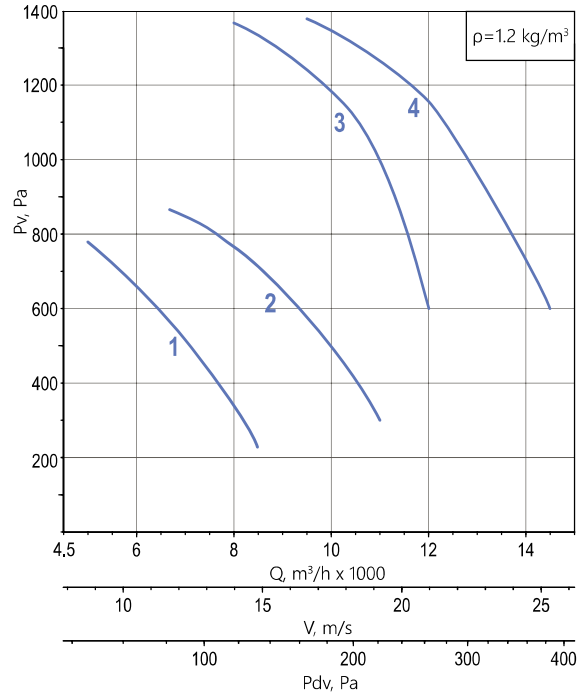
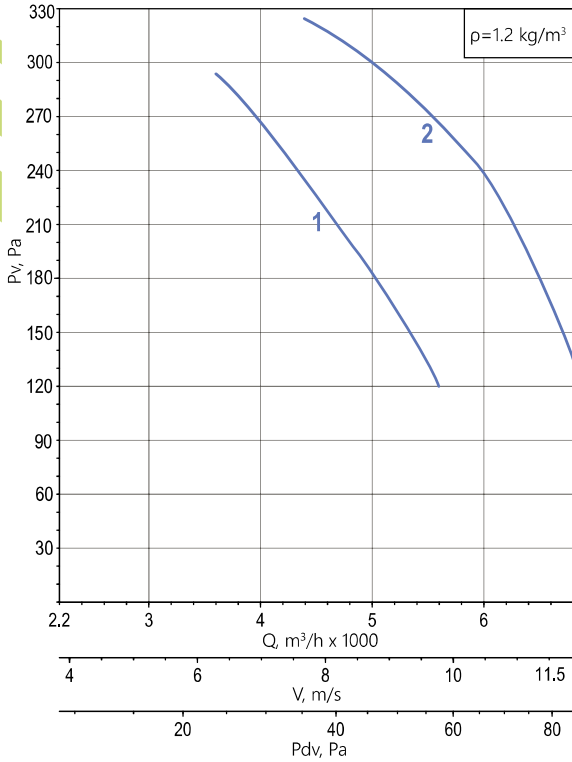

Motor size	L, mm
• 63	910
• 71 • 80	1030
• 100	1070

NOTE:

* Weight specified for OZA-F 300. When changing the motor type, the weight may change. The company reserves the right to change the size and configuration without prior notice.

ADDITIONAL EQUIPMENT

silencer OZA-GKK	inlet header OZA-VKO	flat adapter OZA-PEP	counter flange OZA-FOT	protective mesh OZA-SEM, OZA-SEB
check valve OZA-KLR	mounting support OZA-MOP	roof adapter OZA-PEK	weather protection hood OZA-ZNT	
grille OZA-R50	flexible connector OZA-COM	toroidal adapter OZA-PET	frequency converter ASC	straight section of the duct OZA-PUV
fan control cabinet SAU-PPV, SAU-SPV (up to 7.5 kW) separate cabinet for each motor				





OZA-F 300/301-050

Curve number	Number of poles	Motor size	Total power Nsum, kW	Impeller	α , deg	Current, A at 380V	Weight*, kg
1	6	63	0,36 (2x0,18)**	B	50	1,6	63,4
2					55		
3					60		

Curve number	Number of poles	Motor size	Total power Nsum, kW	Impeller	α , deg	Current, A at 380V	Weight, kg
1	4	63	0,5 (2x0,25)	A	50	1,64	62
2		71	1,1 (2x0,55)	B	50	3,5	70,8
3		71	1,5 (2x0,75)		55	4,4	73,8
4					60		

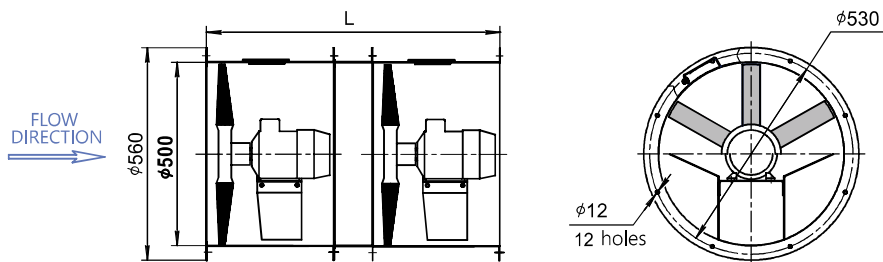
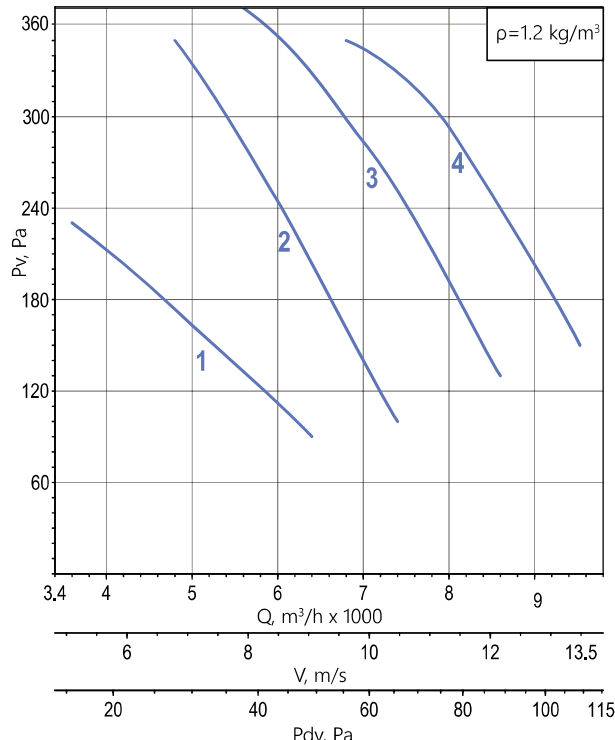
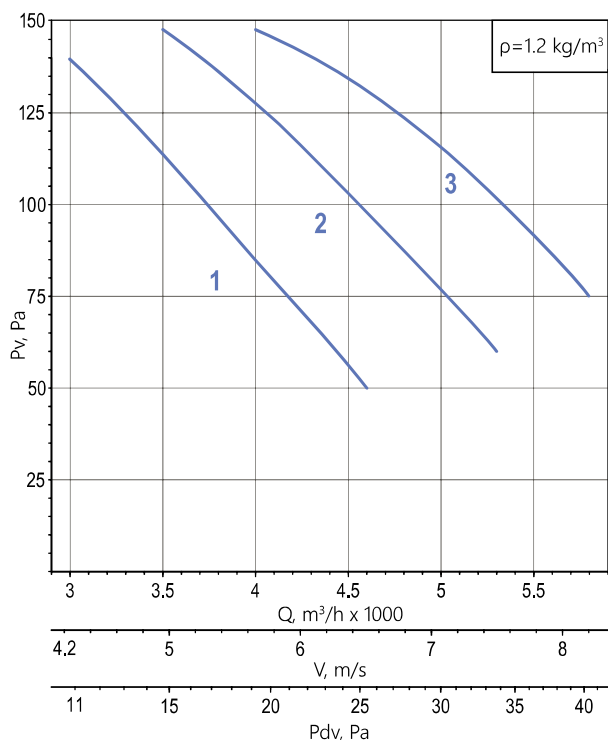

Motor size	L, mm
-63	910
-71	1030

NOTE:
 * Weight specified for OZA-F 300. When changing the motor type, the weight may change.
 ** "N" and "CR1" fan design only.
 The company reserves the right to change the size and configuration without prior notice.

ADDITIONAL EQUIPMENT				
silencer OZA-GKK	inlet header OZA-VKO	flat adapter OZA-PEP	counter flange OZA-FOT	protective mesh OZA-SEM, OZA-SEB
check valve OZA-KLR	mounting support OZA-MOP	roof adapter OZA-PEK	weather protection hood OZA-ZNT	straight section of the duct OZA-PUV
grille OZA-R50	flexible connector OZA-COM	toroidal adapter OZA-PET	frequency converter ASC	
fan control cabinet SAU-PPV, SAU-SPV (up to 7.5 kW) separate cabinet for each motor				





OZA-F 300/301-050

Curve number	Number of poles	Motor size	Total power Nsum, kW	Impeller	α , deg	Current, A at 380V	Weight*, kg
1	2	80	4,4 (2x2,2)	A	50	10	81,8
2		100	8 (2x4,0)	B	50	16,8	103,8
3		100	11 (2x5,5)		55	22	121,8
4		112	15 (2x7,5)		60	30,4	167,8

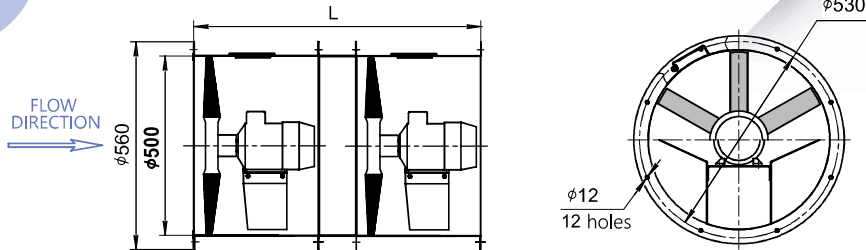
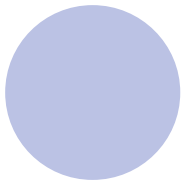
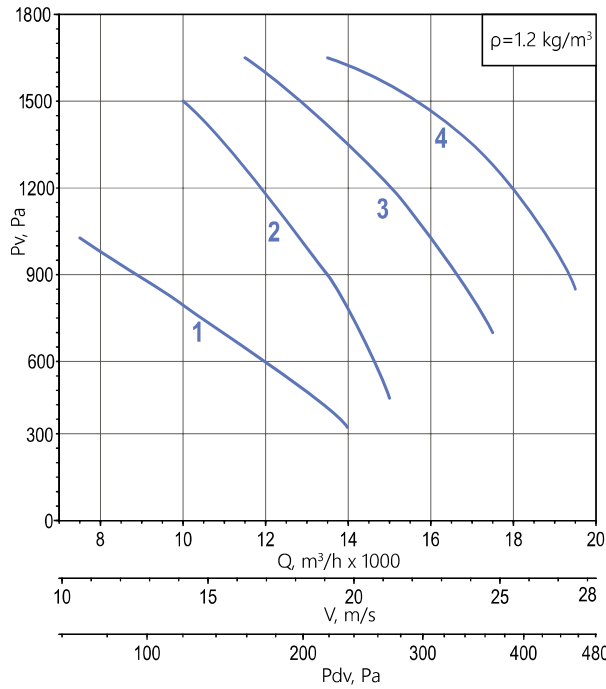

Motor size	L, mm
•80	1030
•100	1070
•112	1400

NOTE:

* Weight specified for OZA-F 300. When changing the motor type, the weight may change. The company reserves the right to change the size and configuration without prior notice.

ADDITIONAL EQUIPMENT

silencer OZA-GKK	inlet header OZA-VKO	flat adapter OZA-PEP	counter flange OZA-FOT	protective mesh OZA-SEM, OZA-SEB
check valve OZA-KLR	mounting support OZA-MOP	roof adapter OZA-PEK	weather protection hood OZA-ZNT	
grille OZA-R50	flexible connector OZA-COM	toroidal adapter OZA-PET	frequency converter ASC	straight section of the duct OZA-PUV
fan control cabinet SAU-PPV, SAU-SPV (up to 7.5 kW) separate cabinet for each motor				





OZA-F 300/301-056

Curve number	Number of poles	Motor size	Total power Nsum, kW	Impeller	α , deg	Current, A at 380V	Weight*, kg
1	6	71	0,74 (2x0,37)	B	55	2,66	74,1
2					55		
3		71	1,1 (2x0,55)	L	60	3,8	76,7
4					65		

Curve number	Number of poles	Motor size	Total power Nsum, kW	Impeller	α , deg	Current, A at 380V	Weight, kg
1	4	63	0,74 (2x0,37)	A	50	2,24	64,7
2		71	1,1 (2x0,55)		55	3,5	69,7
3		71	1,5 (2x0,75)	B	52	4,4	74,9
4		80	2,2 (2x1,1)		57	6,08	82,9
5		90	4,4 (2x2,2)		L	65	10,6

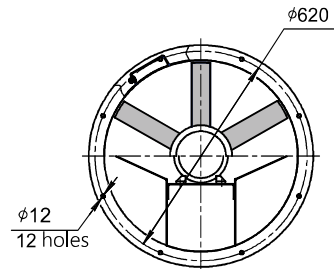
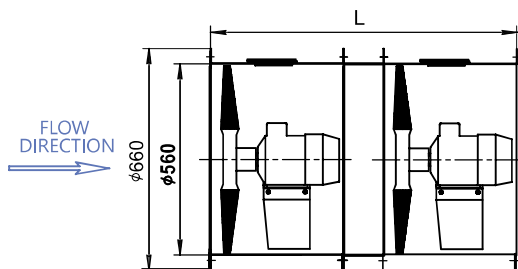
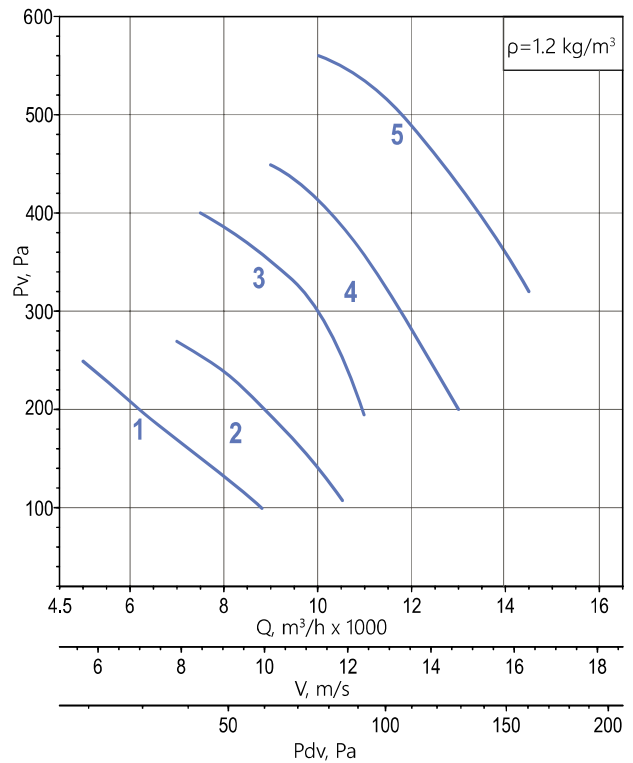
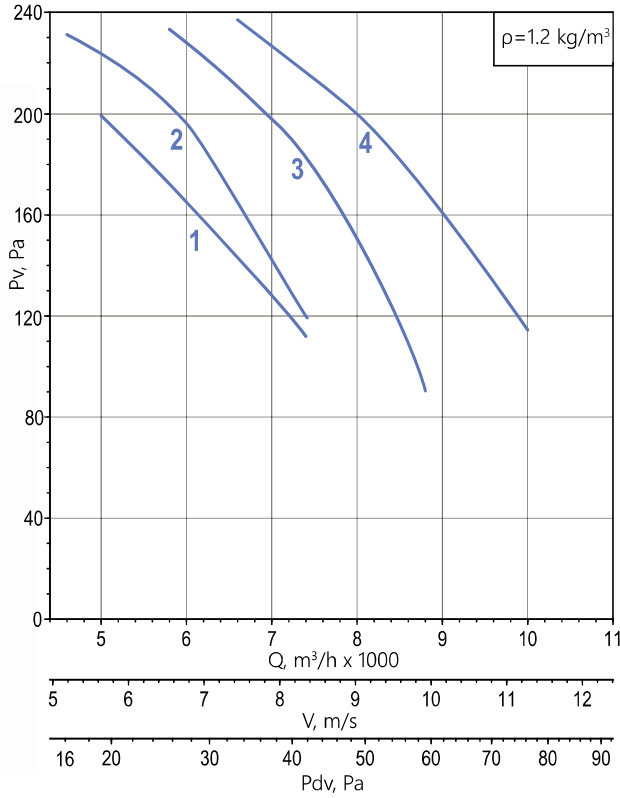

Motor size	L, mm
• 63 • 71 • 80	1030
• 90	1170

NOTE:
 * Weight specified for OZA-F 300. When changing the motor type, the weight may change.
 The company reserves the right to change the size and configuration without prior notice.

ADDITIONAL EQUIPMENT				
silencer OZA-GKK	inlet header OZA-VKO	flat adapter OZA-PEP	counter flange OZA-FOT	protective mesh OZA-SEM, OZA-SEB
check valve OZA-KLR	mounting support OZA-MOP	roof adapter OZA-PEK	weather protection hood OZA-ZNT	straight section of the duct OZA-PUV
grille OZA-R50	flexible connector OZA-COM	toroidal adapter OZA-PET	frequency converter ASC	
fan control cabinet SAU-PPV, SAU-SPV (up to 7.5 kW) separate cabinet for each motor				

ENERGY EFFICIENT AXIAL FANS





OZA-F 300/301-056

Curve number	Number of poles	Motor size	Total power Nsum, kW	Impeller	α , deg	Current, A at 380V	Weight*, kg
1	2	90	6 (2x3,0)	A	50	13	87,5
2		100	8 (2x4,0)		55	16,8	102,7
3		112	15 (2x7,5)	B	50	30,4	168,9
4		132	22 (2x11,0)		55	43,6	224,1
5		160	30 (2x15,0)	L	60	60	310

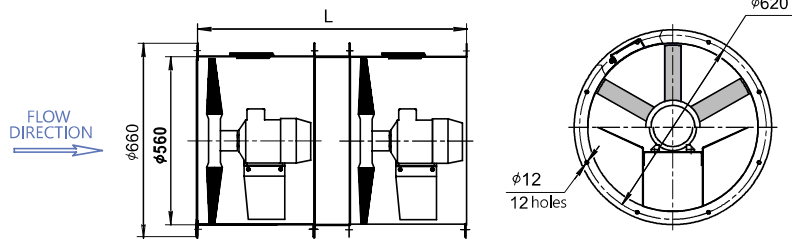
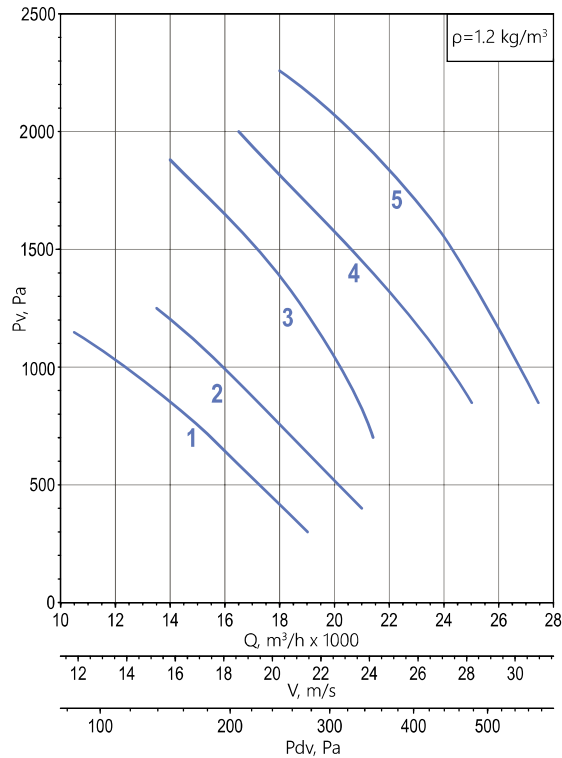

Motor size	L, mm
• 90 • 100	1170
• 112 • 132	1400
• 160	1780

NOTE:

* Weight specified for OZA-F 300. When changing the motor type, the weight may change. The company reserves the right to change the size and configuration without prior notice.

ADDITIONAL EQUIPMENT

silencer OZA-GKK	inlet header OZA-VKO	flat adapter OZA-PEP	counter flange OZA-FOT	protective mesh OZA-SEM, OZA-SEB
check valve OZA-KLR	mounting support OZA-MOP	roof adapter OZA-PEK	weather protection hood OZA-ZNT	
grille OZA-R50	flexible connector OZA-COM	toroidal adapter OZA-PET	frequency converter ASC	straight section of the duct OZA-PUV
fan control cabinet SAU-PPV, SAU-SPV (up to 7.5 kW) separate cabinet for each motor				





OZA-F 300/301-063

Curve number	Number of poles	Motor size	Total power Nsum, kW	Impeller	α , deg	Current, A at 380V	Weight*, kg
1	6	71	1,1 (2x0,55)	B	55	3,8	80,8
2					57		
3				L	65		
4					80	1,5 (2x0,75)	65

Curve number	Number of poles	Motor size	Total power Nsum, kW	Impeller	α , deg	Current, A at 380V	Weight, kg
1	4	63	0,74 (2x0,37)	A	45	2,24	69,6
2		71	1,1 (2x0,75)		50	3,5	75,6
3		B	80	2,2 (2x1,1)	50	6,08	88,3
4			80	3 (2x1,5)	55	7,9	92,3
5		I	90	4,4 (2x2,2)	65	10,6	102,3
6		L	100	6 (2x3,0)	65	14,4	110,4

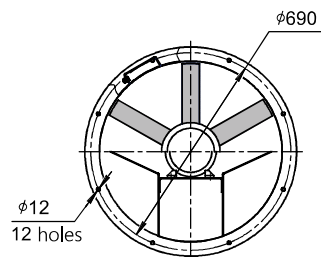
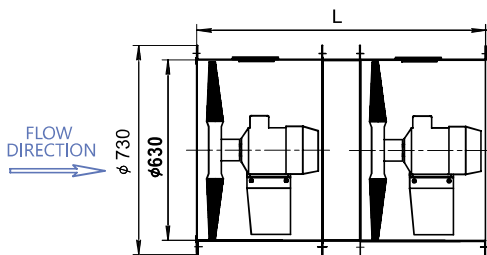
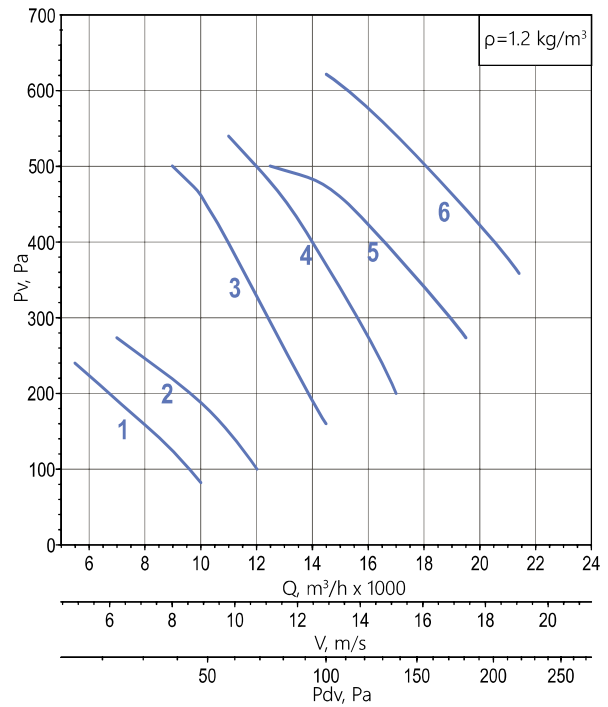
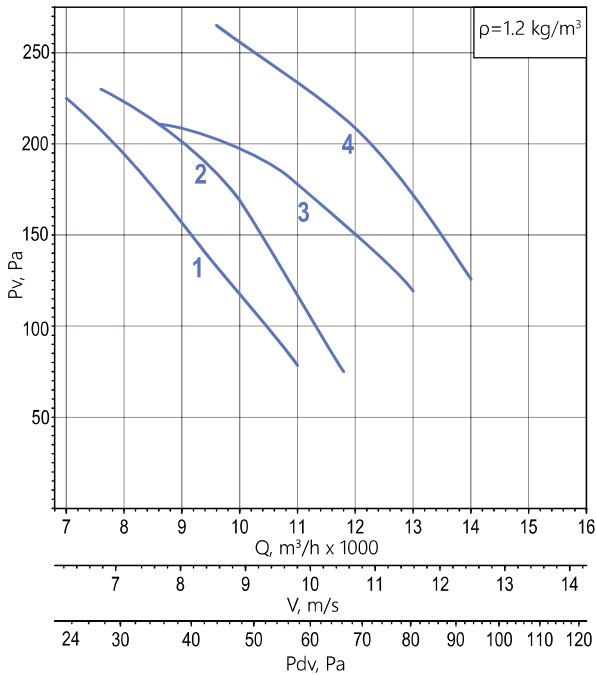

Motor size	L, mm
•63 •71 •80	1030
•90 •100	1170

NOTE:
 * Weight specified for OZA-F 300. When changing the motor type, the weight may change.
 The company reserves the right to change the size and configuration without prior notice.

ADDITIONAL EQUIPMENT				
silencer OZA-GKK	inlet header OZA-VKO	flat adapter OZA-PEP	counter flange OZA-FOT	protective mesh OZA-SEM, OZA-SEB
check valve OZA-KLR	mounting support OZA-MOP	roof adapter OZA-PEK	weather protection hood OZA-ZNT	
grille OZA-R50	flexible connector OZA-COM	toroidal adapter OZA-PET	frequency converter ASC	straight section of the duct OZA-PUV
fan control cabinet SAU-PPV, SAU-SPV (up to 7.5 kW) separate cabinet for each motor				





OZA-F 300/301-063

Curve number	Number of poles	Motor size	Total power Nsum, kW	Impeller	α , deg	Current, A at 380V	Weight*, kg
1	2	90	6 (2x3,0)	A	45	13	93,2
2		100	11 (2x5,5)		50	22	125,6
3		112	15 (2x7,5)	B	55	30,4	167,6
4		160	30 (2x15,0)		55	60	314,8

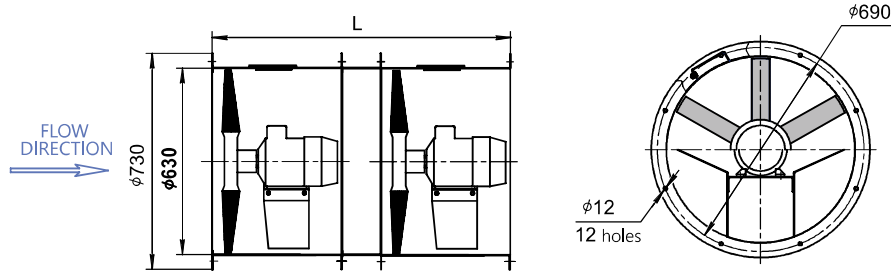
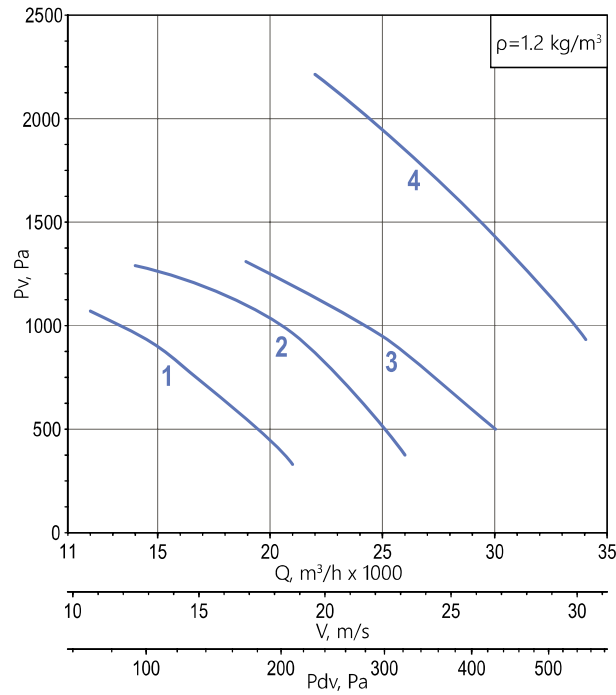

Motor size	L, mm
• 90 • 100	1170
• 112 • 132	1400
• 160	1780

NOTE:

* Weight specified for OZA-F 300. When changing the motor type, the weight may change. The company reserves the right to change the size and configuration without prior notice.

ADDITIONAL EQUIPMENT

silencer OZA-GKK	inlet header OZA-VKO	flat adapter OZA-PEP	counter flange OZA-FOT	protective mesh OZA-SEM, OZA-SEB
check valve OZA-KLR	mounting support OZA-MOP	roof adapter OZA-PEK	weather protection hood OZA-ZNT	straight section of the duct OZA-PUV
grille OZA-R50	flexible connector OZA-COM	toroidal adapter OZA-PET	frequency converter ASC	
fan control cabinet SAU-PPV, SAU-SPV (up to 7.5 kW) separate cabinet for each motor				

ENERGY EFFICIENT AXIAL FANS



OZA-F 300/301-071

Curve number	Number of poles	Motor size	Total power Nsum, kW	Impeller	α , deg	Current, A at 380V	Weight*, kg
1	6	71	1,1 (2x0,55)	B	52	3,8	91,1
2		80	1,5 (2x0,75)	L	55	4,58	103,1
3		80	2,2 (2x1,1)		60	6,36	107,1
4					65	6,36	107,1

Curve number	Number of poles	Motor size	Total power Nsum, kW	Impeller	α , deg	Current, A at 380V	Weight, kg
1	4	71	1,5 (2x0,75)	E	50	4,4	88,9
2		90	4,4 (2x2,2)	B	50	10,6	114,3
3					55	10,6	114,3
4		100	6 (2x3,0)	L	57	14,4	121,9
5		112	11 (2x5,5)		65	24,6	200,9

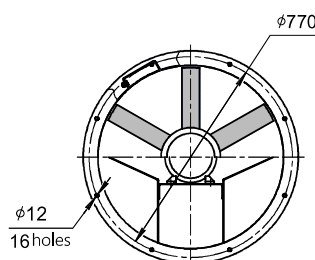
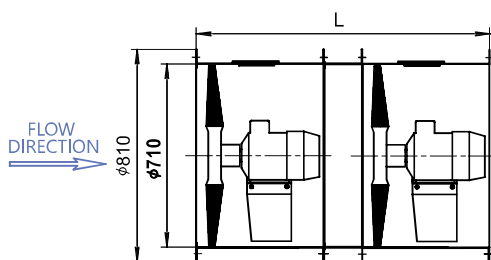
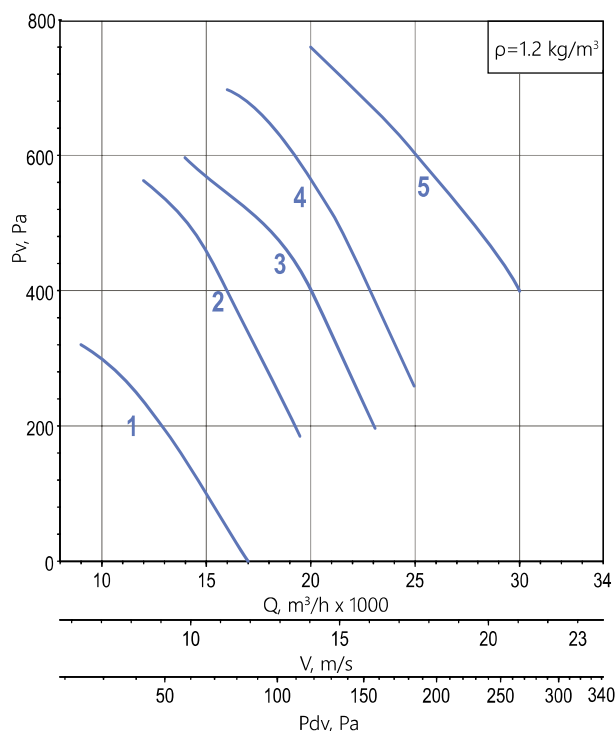
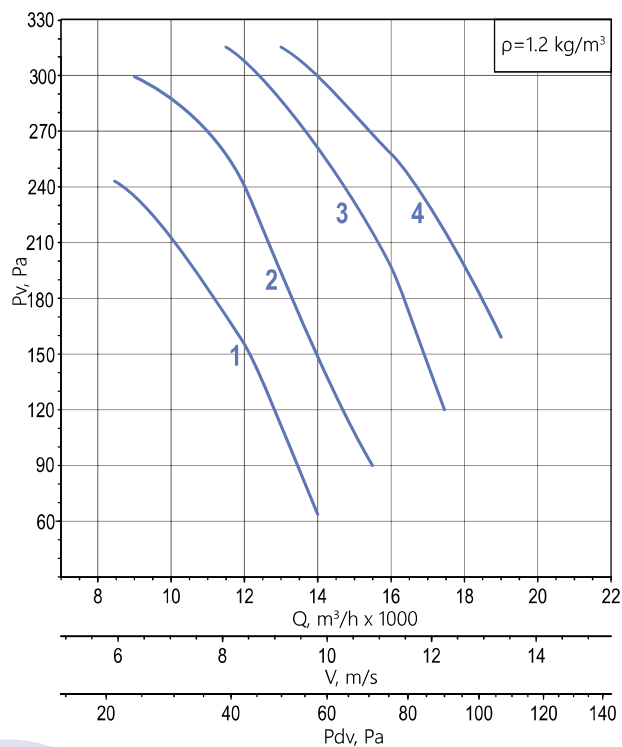

Motor size	L, mm
•71 •80	1030
•90 •100	1170
•112	1400

NOTE:

* Weight specified for OZA-F 300. When changing the motor type, the weight may change. The company reserves the right to change the size and configuration without prior notice.

ADDITIONAL EQUIPMENT

silencer OZA-GKK	inlet header OZA-VKO	flat adapter OZA-PEP	counter flange OZA-FOT	protective mesh OZA-SEM, OZA-SEB
check valve OZA-KLR	mounting support OZA-MOP	roof adapter OZA-PEK	weather protection hood OZA-ZNT	
grille OZA-R50	flexible connector OZA-COM	toroidal adapter OZA-PET	frequency converter ASC	straight section of the duct OZA-PUV

fan control cabinet
SAU-PPV, SAU-SPV
(up to 7.5 kW) separate cabinet for each motor





OZA-F 301-071

Curve number	Number of poles	Motor size	Total power Nsum, kW	Impeller	α , deg	Current, A at 380V	Weight*, kg
1	2	112	15 (2x7,5)	E	50	30,4	176,9
2		132	22 (2x11,0)	A	55	43,6	241,7
3		160	37 (2x18,5)	I	57	72,6	347,7

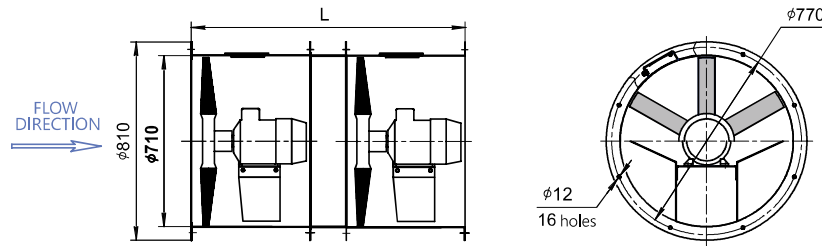
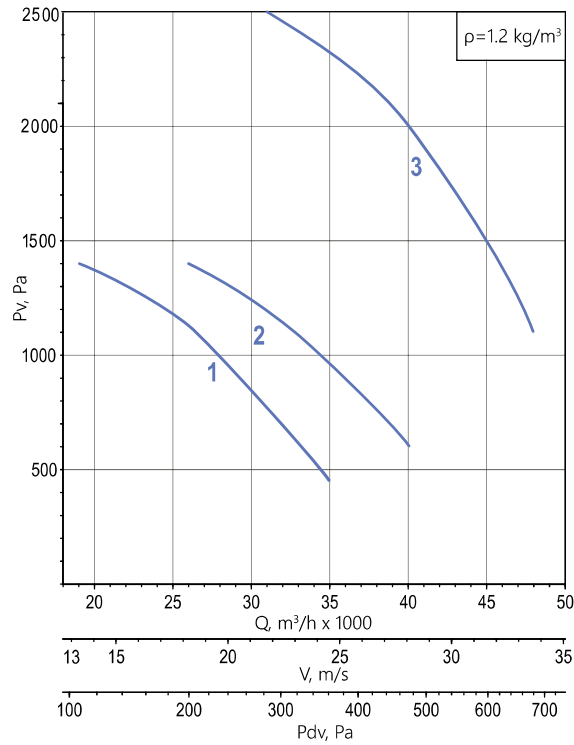

Motor size	L, mm
• 112 • 132	1400
• 160	1780

NOTE:

* Weight specified for OZA-F 300. When changing the motor type, the weight may change. The company reserves the right to change the size and configuration without prior notice.

ADDITIONAL EQUIPMENT

silencer OZA-GKK	inlet header OZA-VKO	flat adapter OZA-PEP	counter flange OZA-FOT	protective mesh OZA-SEM, OZA-SEB
check valve OZA-KLR	mounting support OZA-MOP	roof adapter OZA-PEK	weather protection hood OZA-ZNT	
grille OZA-R50	flexible connector OZA-COM	toroidal adapter OZA-PET	frequency converter ASC	straight section of the duct OZA-PUV
fan control cabinet SAU-PPV, SAU-SPV (up to 7.5 kW) separate cabinet for each motor				



OZA-F 300/301-080

Curve number	Number of poles	Motor size	Total power Nsum, kW	Impeller	α , deg	Current, A at 380V	Weight*, kg
1	6	80	1,5 (2x0,75)	B	50	4,58	132
2		80	2,2 (2x1,1)	L	52	6,36	136
3		90	3 (2x1,5)		57	8,4	153
4		100	4,4 (2x2,2)		65	11,8	169

Curve number	Number of poles	Motor size	Total power Nsum, kW	Impeller	α , deg	Current, A at 380V	Weight, kg
1	4	80	3 (2x1,5)	A	50	7,9	130,2
2		90	4,4 (2x2,2)	B	50	10,6	149,2
3		100	8 (2x4,0)	L	52	18,6	175
4		112	11 (2x5,5)		57	24,6	235
5		132	15 (2x7,5)		65	32,2	283

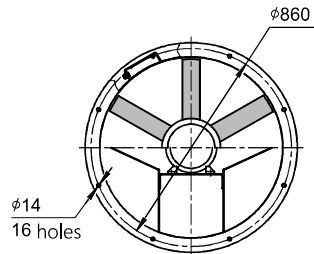
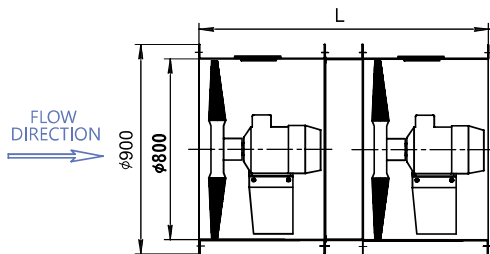
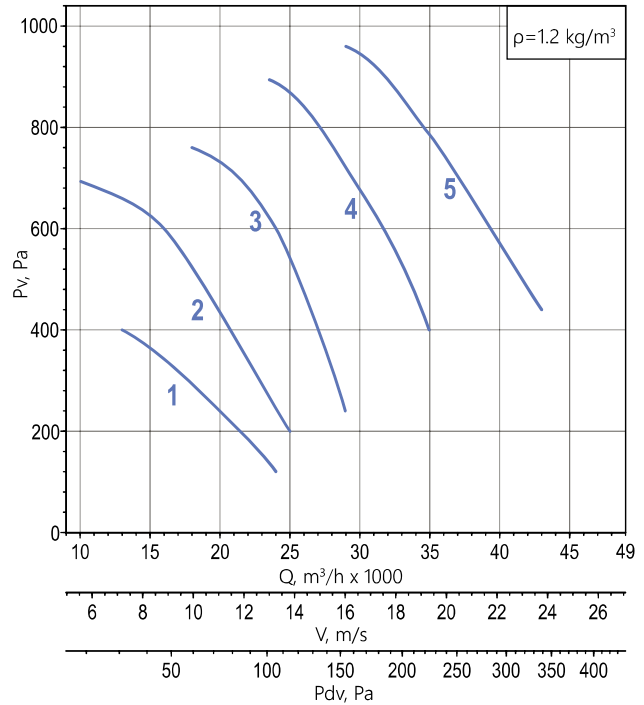
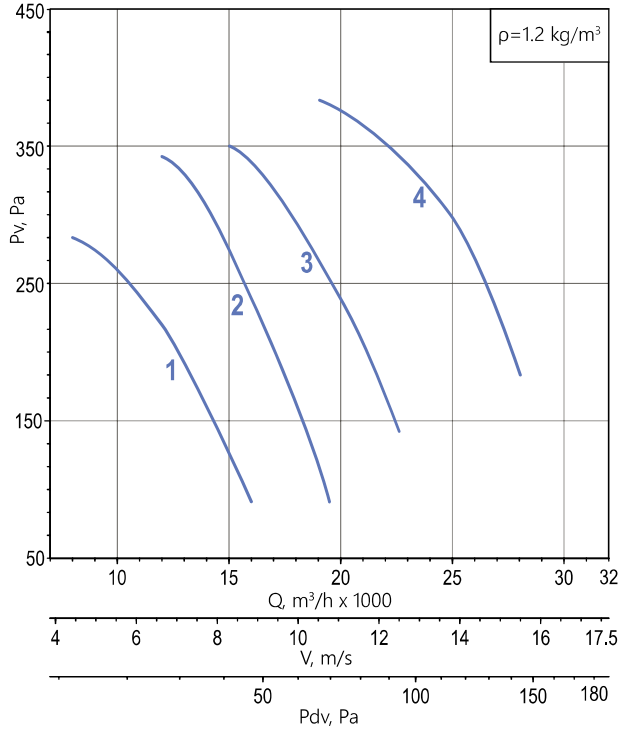

Motor size	L, mm
• 80	1030
• 90 • 100	1170
• 112 • 132	1400

NOTE:
 * Weight specified for OZA-F 300. When changing the motor type, the weight may change.
 The company reserves the right to change the size and configuration without prior notice.

ADDITIONAL EQUIPMENT				
silencer OZA-GKK	inlet header OZA-VKO	flat adapter OZA-PEP	counter flange OZA-FOT	protective mesh OZA-SEM, OZA-SEB
check valve OZA-KLR	mounting support OZA-MOP	roof adapter OZA-PEK	weather protection hood OZA-ZNT	
grille OZA-R50	flexible connector OZA-COM	toroidal adapter OZA-PET	frequency converter ASC	straight section of the duct OZA-PUV
fan control cabinet SAU-PPV, SAU-SPV (up to 7.5 kW) separate cabinet for each motor				



OZA-F 300/301-090

Curve number	Number of poles	Motor size	Total power Nsum, kW	Impeller	α , deg	Current, A at 380V	Weight*, kg
1	8	90	2,2 (2x1,1)	L	60	6,54	174,9
2		100	3 (2x1,5)		65	9,0	181,9
3					70	12,8	223,3
4		112	4,4 (2x2,2)	P	70	12,8	223,3

Curve number	Number of poles	Motor size	Total power Nsum, kW	Impeller	α , deg	Current, A at 380V	Weight, kg
1	6	80	2,2 (2x1,1)	B	52	6,36	150,9
2		100	4,4 (2x2,2)	L	55	11,8	187,9
3					60		
4					65		
5		132	11 (2x5,5)	P	70	26,8	311,3
6					70		

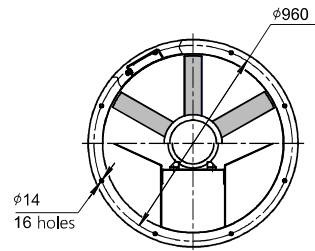
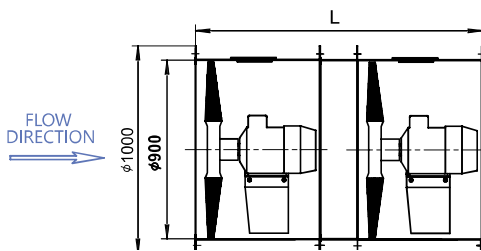
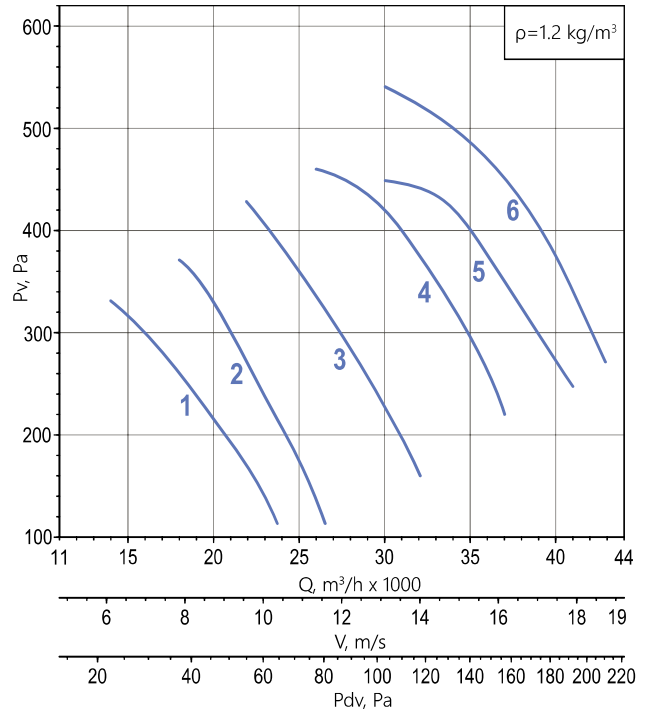
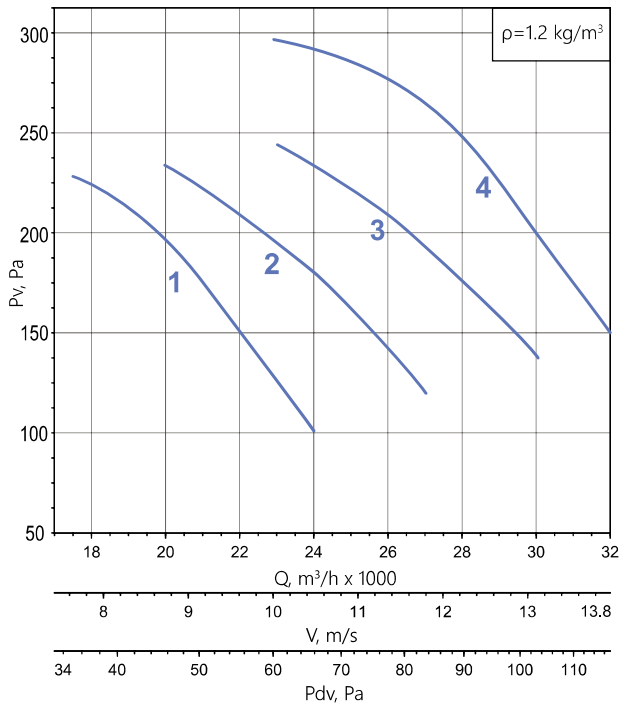

Motor size	L, mm
• 80	1030
• 90 • 100	1170
• 112 • 132	1400

NOTE:

* Weight specified for OZA-F 300. When changing the motor type, the weight may change. The company reserves the right to change the size and configuration without prior notice.

ADDITIONAL EQUIPMENT

silencer OZA-GKK	inlet header OZA-VKO	flat adapter OZA-PEP	counter flange OZA-FOT	protective mesh OZA-SEM, OZA-SEB
check valve OZA-KLR	mounting support OZA-MOP	roof adapter OZA-PEK	weather protection hood OZA-ZNT	
grille OZA-R50	flexible connector OZA-COM	toroidal adapter OZA-PET	frequency converter ASC	straight section of the duct OZA-PUV
fan control cabinet SAU-PPV, SAU-SPV (up to 7.5 kW) separate cabinet for each motor				



OZA-F 300/301-090

Curve number	Number of poles	Motor size	Total power Nsum, kW	Impeller	α , deg	Current, A at 380V	Weight*, kg
1	4	100	6 (2x3,0)	B	50	14,4	171,9
2		112	11 (2x5,5)		52	24,6	253,3
3		132	15 (2x7,5)		57	32,2	301,3
4		L	132	22 (2x11,0)	60	46,2	325,3
5					65	61,6	423,3
6			160	30 (2x15,0)	70	61,6	423,3
7			160	37 (2x18,5)	P	70	75,6

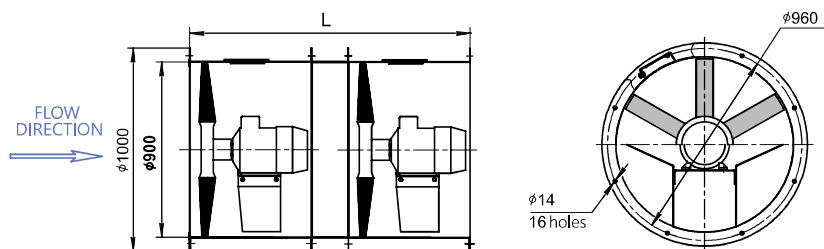
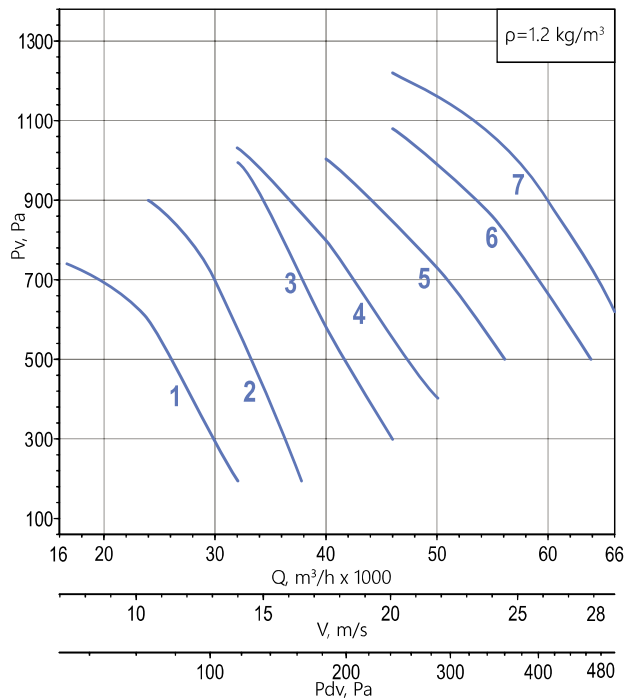

Motor size	L, mm
*100	1170
*112 *132	1400
*160	1780

NOTE:
 * Weight specified for OZA-F 300. When changing the motor type, the weight may change.
 The company reserves the right to change the size and configuration without prior notice.

ADDITIONAL EQUIPMENT				
silencer OZA-GKK	inlet header OZA-VKO	flat adapter OZA-PEP	counter flange OZA-FOT	protective mesh OZA-SEM, OZA-SEB
check valve OZA-KLR	mounting support OZA-MOP	roof adapter OZA-PEK	weather protection hood OZA-ZNT	
grille OZA-R50	flexible connector OZA-COM	toroidal adapter OZA-PET	frequency converter ASC	straight section of the duct OZA-PUV
fan control cabinet SAU-PPV, SAU-SPV (up to 7.5 kW) separate cabinet for each motor				





OZA-F 300/301-100

Curve number	Number of poles	Motor size	Total power Nsum, kW	Impeller	α , deg	Current, A at 380V	Weight*, kg
1	8	90	2,2 (2x1,1)	B	57	6,54	186,4
2		100	3 (2x1,5)	L	60	9,0	198,4
3		112	4,4 (2x2,2)	D	65	12,8	233,2
4		112	6 (2x3,0)		70	17,2	251,2
5				P	70	17,2	252

Curve number	Number of poles	Motor size	Total power Nsum, kW	Impeller	α , deg	Current, A at 380V	Weight, kg
1	6	90	3 (2x1,5)	B	50	8,4	183,4
2		100	4,4 (2x2,2)		55	11,8	199,4
3		112	6 (2x3,0)		60	15,8	257,2
4		132	11 (2x5,5)	D	65	26,8	321,2
5		132	15 (2x7,5)		70	34,4	357,2
6				P	70	34,4	358
7				T	70	49,2	447,2

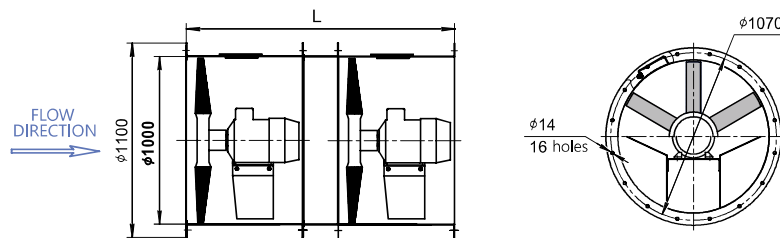
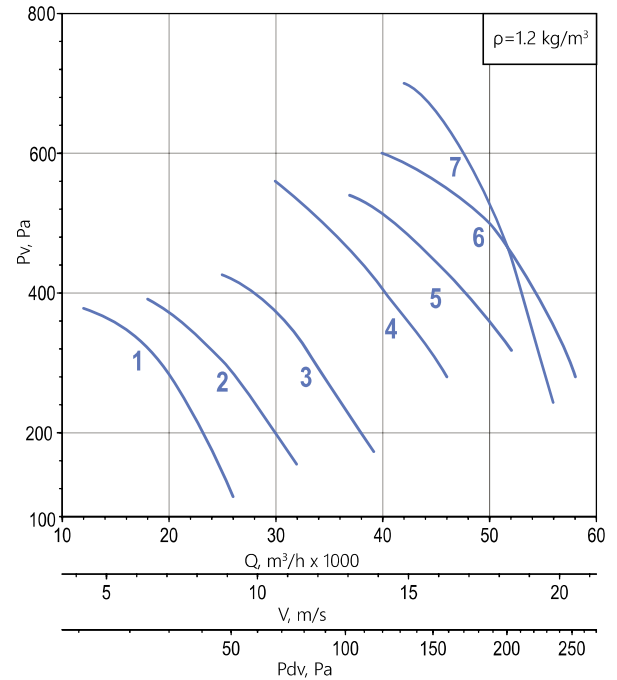
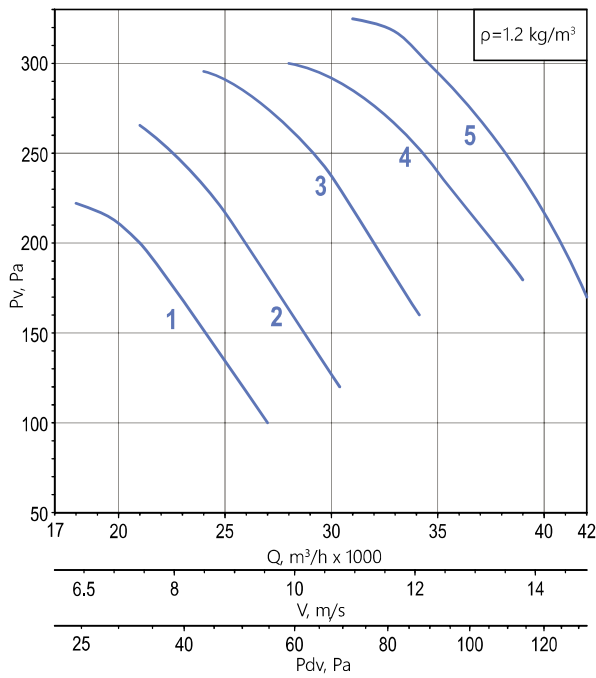

Motor size	L, mm
• 90 • 100	1170
• 112 • 132	1400
• 160	1780

NOTE:

* Weight specified for OZA-F 300. When changing the motor type, the weight may change.

The company reserves the right to change the size and configuration without prior notice.

ADDITIONAL EQUIPMENT

silencer OZA-GKK	inlet header OZA-VKO	flat adapter OZA-PEP	counter flange OZA-FOT	protective mesh OZA-SEM, OZA-SEB
check valve OZA-KLR	mounting support OZA-MOP	roof adapter OZA-PEK	weather protection hood OZA-ZNT	
grille OZA-R50	flexible connector OZA-COM	toroidal adapter OZA-PET	frequency converter ASC	straight section of the duct OZA-PUV

fan control cabinet
SAU-PPV, SAU-SPV

(up to 7.5 kW) separate cabinet for each motor





OZA-F 300/301-100

Curve number	Number of poles	Motor size	Total power Nsum, kW	Impeller	α , deg	Current, A at 380V	Weight*, kg
1	4	100	6 (2x3,0)	B	45	14,4	187,4
2		112	11 (2x5,5)		50	24,6	265,2
3		132	15 (2x7,5)		55	32,2	313,5
4		132	22 (2x11,0)		60	46,2	337,2
5		160	37 (2x18,5)	D	65	75,6	482
6		180	44 (2x22,0)		70	88,8	525
7		180	60 (2x30,0)		P	70	119,2

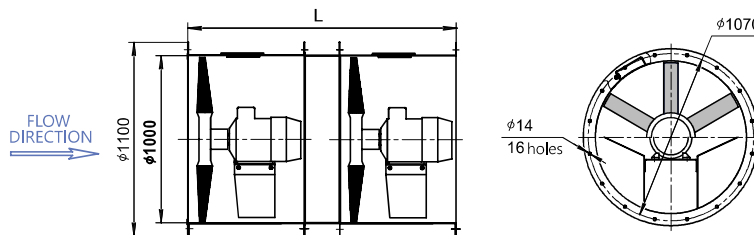
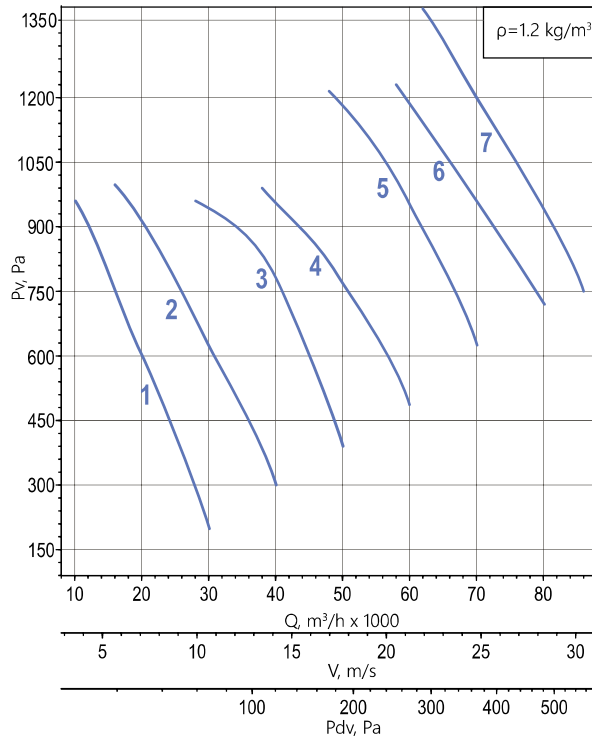

Motor size	L, mm
• 100	1170
• 112 • 132	1400
• 160 • 180	1780

NOTE:
 * Weight specified for OZA-F 300. When changing the motor type, the weight may change.
 The company reserves the right to change the size and configuration without prior notice.

ADDITIONAL EQUIPMENT				
silencer OZA-GKK	inlet header OZA-VKO	flat adapter OZA-PEP	counter flange OZA-FOT	protective mesh OZA-SEM, OZA-SEB
check valve OZA-KLR	mounting support OZA-MOP	roof adapter OZA-PEK	weather protection hood OZA-ZNT	
grille OZA-R50	flexible connector OZA-COM	toroidal adapter OZA-PET	frequency converter ASC	straight section of the duct OZA-PUV
fan control cabinet SAU-PPV, SAU-SPV (up to 7.5 kW) separate cabinet for each motor				





OZA-F 300/301-112

Curve number	Number of poles	Motor size	Total power Nsum, kW	Impeller	α , deg	Current, A at 380V	Weight*, kg	Curve number	Number of poles	Motor size	Total power Nsum, kW	Impeller	α , deg	Current, A at 380V	Weight, kg	
1	8	90	2,2 (2x1,1)	G	52	6,54	209,5	1	6	112	6 (2x3,0)	G	52	15,8	281	
2		100	3 (2x1,5)	M	55	9,0	215,6	2		112	8 (2x4,0)	M	55	20,6	299	
3		112	4,4 (2x2,2)		60	12,8	237	3		132	11 (2x5,5)		D	60	26,8	345,5
4		112	6 (2x3,0)	D	65	17,2	267,5	4		132	15 (2x7,5)	D		65	34,4	373
5		132	8 (2x4,0)		T	70	21,6	293		5	160			22 (2x11,0)	T	70
6		132	11 (2x5,5)	70		29,4	327,5	6		160	30 (2x15,0)	70		66		545,5

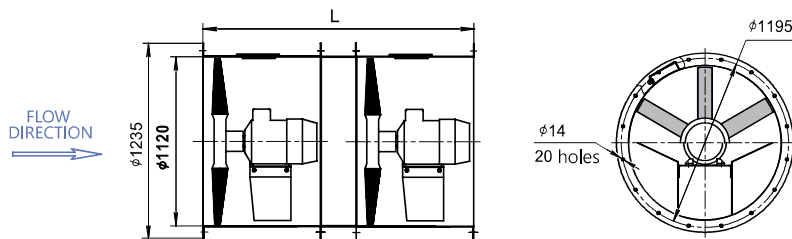
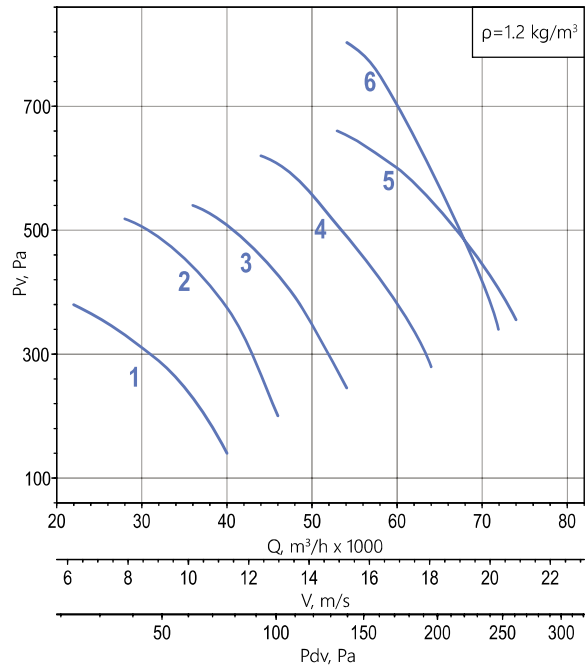
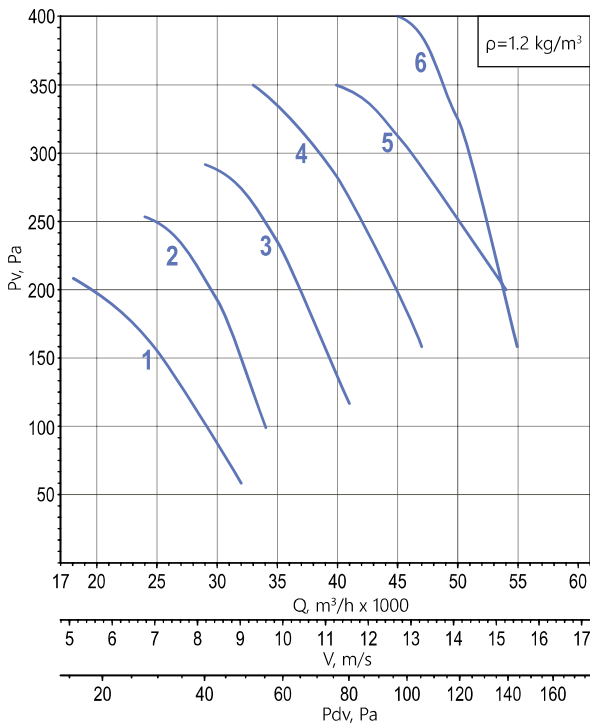

Motor size	L, mm
• 90 • 100	1170
• 112 • 132	1400
• 160	1780

NOTE:
 * Weight specified for OZA-F 300. When changing the motor type, the weight may change.
 The company reserves the right to change the size and configuration without prior notice.

ADDITIONAL EQUIPMENT

silencer OZA-GKK	inlet header OZA-VKO	flat adapter OZA-PEP	counter flange OZA-FOT	protective mesh OZA-SEM, OZA-SEB
check valve OZA-KLR	mounting support OZA-MOP	roof adapter OZA-PEK	weather protection hood OZA-ZNT	
grille OZA-R50	flexible connector OZA-COM	toroidal adapter OZA-PET	frequency converter ASC	straight section of the duct OZA-PUV
fan control cabinet SAU-PPV, SAU-SPV (up to 7.5 kW) separate cabinet for each motor				



OZA-F 300/301-112



Curve number	Number of poles	Motor size	Total power Nsum, kW	Impeller	α , deg	Current, A at 380V	Weight*, kg
1	4	100	8 (2×4,0)	G	45	18,6	220
2		132	15 (2×7,5)		50	32,2	333
3		132	22 (2×11,0)	M	52	46,2	357,5
4		160	37 (2×18,5)		57	75,6	509
5		180	44 (2×22,0)		60	88,8	545,5
6		180	60 (2×30,0)	D	65	119,2	611
7		200	74 (2×37,0)		70	146,2	730

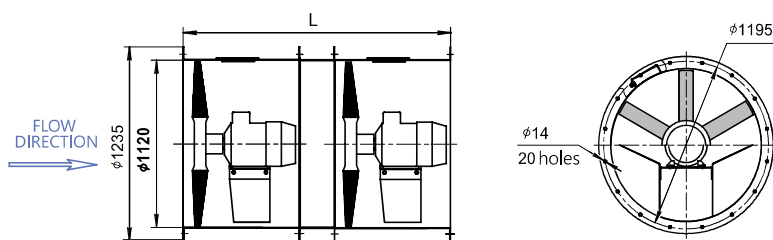
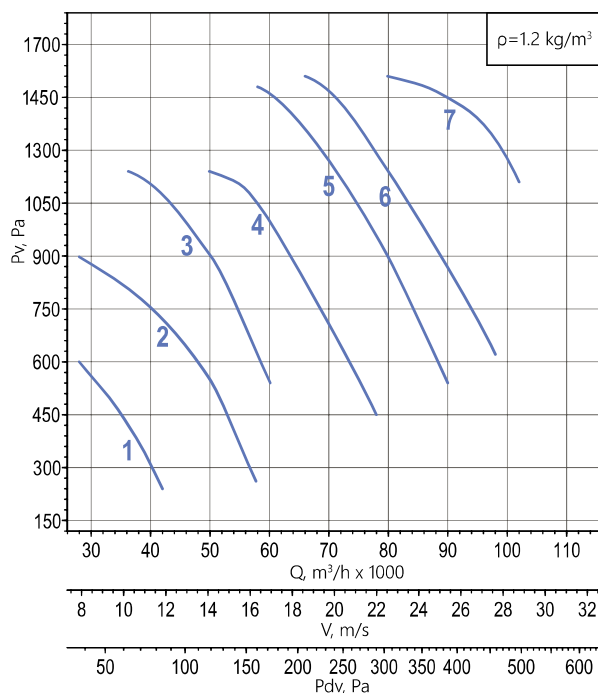

Motor size	L, mm
•100	1170
•112 •132	1400
•160 •180	1780
•200	2050

NOTE:
 * Weight specified for OZA-F 300. When changing the motor type, the weight may change.
 The company reserves the right to change the size and configuration without prior notice.

ADDITIONAL EQUIPMENT				
silencer OZA-GKK	inlet header OZA-VKO	flat adapter OZA-PEP	counter flange OZA-FOT	protective mesh OZA-SEM, OZA-SEB
check valve OZA-KLR	mounting support OZA-MOP	roof adapter OZA-PEK	weather protection hood OZA-ZNT	
grille OZA-R50	flexible connector OZA-COM	toroidal adapter OZA-PET	frequency converter ASC	straight section of the duct OZA-PUV
fan control cabinet SAU-PPV, SAU-SPV (up to 7.5 kW) separate cabinet for each motor				





OZA-F 301-125

Curve number	Number of poles	Motor size	Total power Nsum, kW	Impeller	α , deg	Current, A at 380V	Weight*, kg	Curve number	Number of poles	Motor size	Total power Nsum, kW	Impeller	α , deg	Current, A at 380V	Weight, kg
1	8	100	3 (2x1,5)	R	50	9,0	234	1	6	112	8 (2x4,0)	R	50	20,6	320
2		112	6 (2x3,0)	C	52	17,2	296	2		132	11 (2x5,5)	C	52	26,8	372
3		132	8 (2x4,0)		57	21,6	322	3		132	15 (2x7,5)		T	57	34,4
4		T	160	22 (2x11,0)	60	21,6	323	4		160	22 (2x11,0)	60		49,2	520
5			15 (2x7,5)	70	69	520	5	160		30 (2x15,0)	62	66		560	

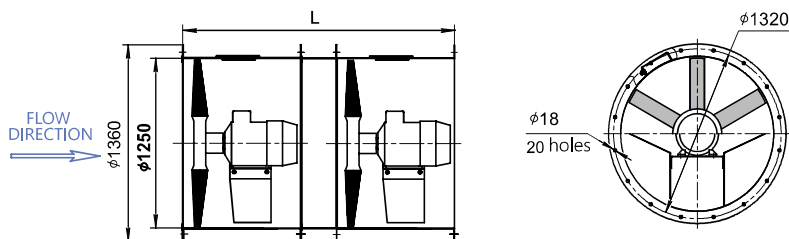
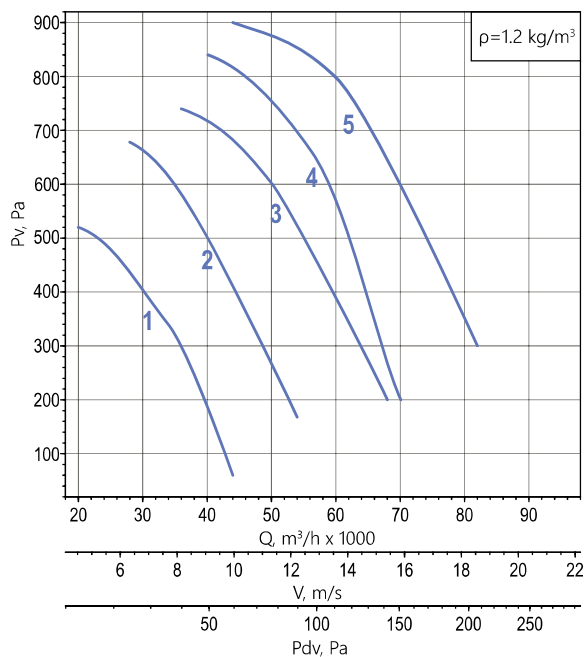
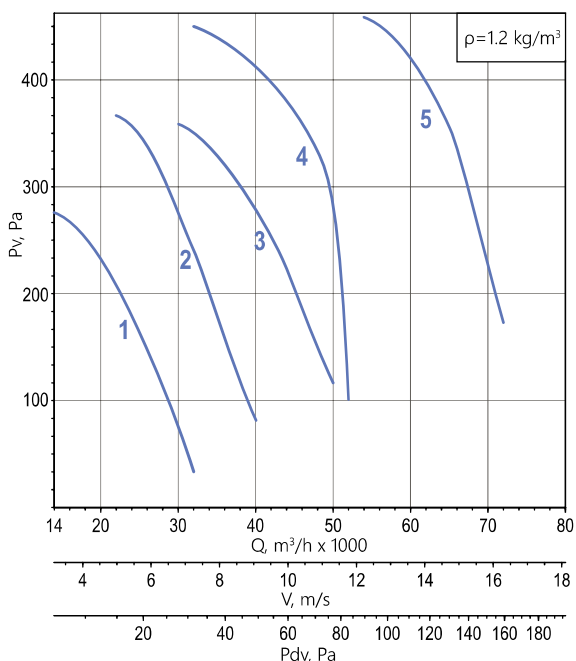

Motor size	L, mm
• 100	1170
• 112 • 132	1400
• 160	1780

NOTE:
 * Weight specified for OZA-F 300. When changing the motor type, the weight may change.
 The company reserves the right to change the size and configuration without prior notice.

ADDITIONAL EQUIPMENT

silencer OZA-GKK	inlet header OZA-VKO	flat adapter OZA-PEP	counter flange OZA-FOT	protective mesh OZA-SEM, OZA-SEB
check valve OZA-KLR	mounting support OZA-MOP	roof adapter OZA-PEK	weather protection hood OZA-ZNT	
grille OZA-R50	flexible connector OZA-COM	toroidal adapter OZA-PET	frequency converter ASC	straight section of the duct OZA-PUV
fan control cabinet SAU-PPV, SAU-SPV (up to 7.5 kW) separate cabinet for each motor				





OZA-F 301-125

Curve number	Number of poles	Motor size	Total power Nsum, kW	Impeller	α , deg	Current, A at 380V	Weight*, kg
1	4	132	22 (2x11,0)	R	50	46,2	386
2		180	44 (2x22,0)	C	52	88,8	578
3		180	60 (2x30,0)		57	119,2	644
4		200	74 (2x37,0)	T	60	146,2	776

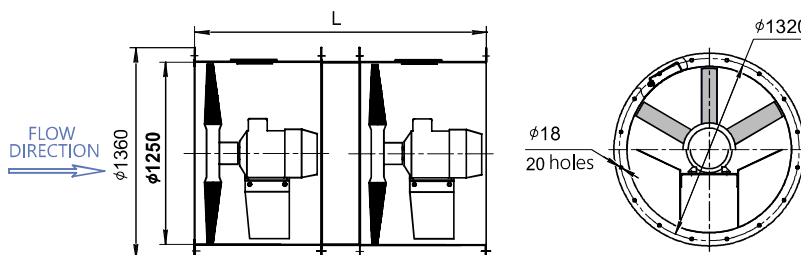
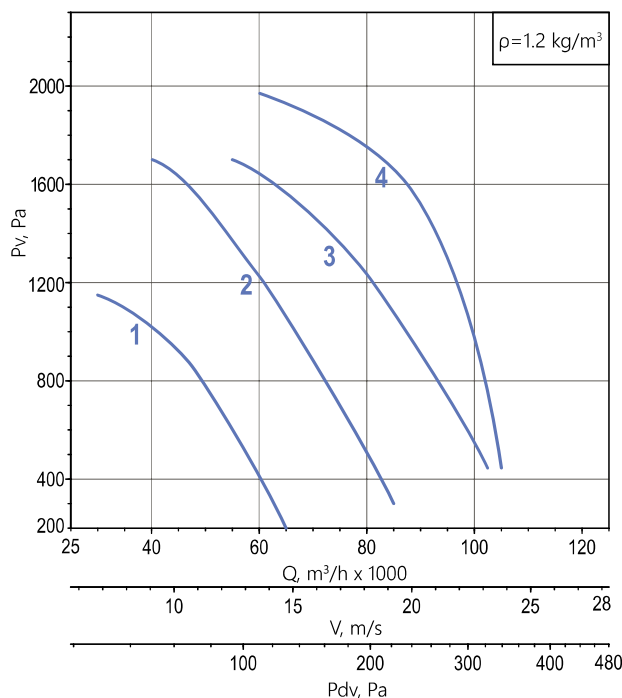

Motor size	L, mm
•132	1400
•180	1780
•200	2050

NOTE:
 * Weight specified for OZA-F 300. When changing the motor type, the weight may change.
 The company reserves the right to change the size and configuration without prior notice.

ADDITIONAL EQUIPMENT

silencer OZA-GKK	inlet header OZA-VKO	flat adapter OZA-PEP	counter flange OZA-FOT	protective mesh OZA-SEM, OZA-SEB
check valve OZA-KLR	mounting support OZA-MOP	roof adapter OZA-PEK	weather protection hood OZA-ZNT	
grille OZA-R50	flexible connector OZA-COM	toroidal adapter OZA-PET	frequency converter ASC	straight section of the duct OZA-PUV
fan control cabinet SAU-PPV, SAU-SPV (up to 7.5 kW) separate cabinet for each motor				





QUESTIONNAIRE

PLEASE FILL IN ALL THE NECESSARY DATA AND SEND IT TO THE NEAREST COMPANY OFFICE

HIGH PRESSURE AXIAL FAN

OZA-F 300 _____ **OZA-F 301** _____

Quantity, pcs: _____

Contact person: _____

Organization: _____

Tel.: _____ e-mail: _____

City: _____

PLEASE CHECK OR SPECIFY THE REQUIRED VALUE

operation mode	efficiency Q, m ³ /h		
	pressure at t=20° C, Pa	total pressure Pv	
		static pressure Psv	
fan size			
design fan	N – general purpose industrial		
	V – explosion-proof		
	CR1 – corrosion-resistant		
	VCR1 – corrosion-resistant explosion-proof		
climatic version	Y1 (Y1)		
	Y2 (Y2)		
	YHL1 (УХЛ1)		
motor	nominal power, kW		
	number of poles		
casing type	long case - 01		
	short case - 02		

Additional information

OZA-GKK silence			
OZA-KLR universal check valve			
OZA-VKO inlet header			
mounting support	OZA-MOP		
	OZA-MOB		
OZA-COM flexible connector	series		
	flange material	stainless steel	
		galvanized steel	
OZA-PEP flat adapter			
OZA-PET toroidal adapter			
OZA-PEK roof adapter			
OZA-PUV straight section of the air duct			
OZA-R50 grille			
protective mesh	OZA-SEM		
	OZA-SEB		
OZA-FOT counter flange			
OZA-ZNT weather protection hood			
FC-051 frequency converter			
SAU-PPV, SAU-SPV fan control cabinet			

Additional conditions:

Customer _____
(signature)

_____ (full name)





REVERSIBLE AXIAL FANS

OZA-RV

reversible axial fans of the OZA-RV series are low and medium pressure fans that can change the direction of rotation of the impeller to change the direction of the gas-and-air flow.

- ventilation and air heating systems;
- fans for drying chambers;
- other sanitary and technological installations.



•040 •045 •050 •056 •063 •071 •080

Reversible axial fans of the OZA-RV series are used in industrial ventilation systems, as well as in air conditioning, air heating and other applications where it is necessary to change the direction of air movement. The design of the fan allows for alternate supply of fresh and exhaust air by using a single device (instead of using the supply and exhaust fans separately).

OZA-RV fans consist of a specially designed impeller, an all-welded casing made of rolled sheet and an asynchronous motor placed in the air flow. Thanks to its special aerodynamic shape, the motor support stand serves as a guide apparatus.

The impeller is made with symmetrical rotary blades. The blade angle is adjustable to achieve maximum efficiency. The symmetrical shape of the blades makes it possible to change the direction of rotation of the impeller to change the direction of the gas-and-air flow (for suction or discharge).

Changing the direction of rotation of the impeller is carried out by changing the direction of rotation of the electric motor shaft. For the standard series of AIP motors with 380V power supply used, this is achieved by swapping the voltage phases connected to it. The operating mode of the fan does not change depending on the direction of the air mixture flow.

The fan housing flanges are solid-rolled, which provides increased rigidity and precision, and ensures the same minimum radial clearance between the wheel blades and the casing along the perimeter of the wheel.

The casing is made of stainless or carbon steel. By special order, it is possible to apply a protective and decorative coating on the fan casing.

The OZA-RV series fans are compact and easy to operate and maintain, creating a low noise level during operation.

They feature power consumption and long service life.

Additional equipment is offered with options: see section "Additional equipment" of the catalog.

- general purpose industrial (N);
- corrosion-resistant (CR1);
- heat-resistant (by special order) (T)

OPERATING CONDITIONS

- ambient temperature:
 - standard -40° C to +40° C;
 - by special order from -60° C to +100° C;
- conditions for the handled medium - presented in the table "Conditions for the handled medium".





EXAMPLE:

Reversible axial fan, size 040/E, impeller blade angle 55°, general purpose industrial design, nominal motor power $N_{nom} = 0.37$ kW, number of poles 4, climatic version Y2

OZA-RV 300-040/E-55-N-00037/4-Y2

- ▶ reversible axial fan
- ▶ fan size (040, 045, 050, 056, 063, 071, 080)
- ▶ impeller modification (B, E, I, L)
- ▶ impeller blade angle α , deg (40...60)
- ▶ design (•N, •CR1, •T)
- ▶ motor parameters²: •I/P
 - l³ - Motor Power Index - see Table 1
 - P - number of poles: 2 (3 000 rpm) 4 (1 500 rpm) 6 (1 000 rpm)
- ▶ climatic version •Y1, •Y2, •YHL1, •YHL2

NOTE:

¹By default all supplied fans are designed for 380V, 50Hz, direct start. Design types of other voltages and connection methods are available upon special agreement.

Special requirements for the fan are specified additionally and agreed upon with the manufacturer.

OZA-RV MOTOR POWER INDEX

Nominal power (N_{nom}), kW	0,18...0,75	1,1...7,5	11...90
Motor Power Index (I)	00018...00075	00110...00750	01100...09000

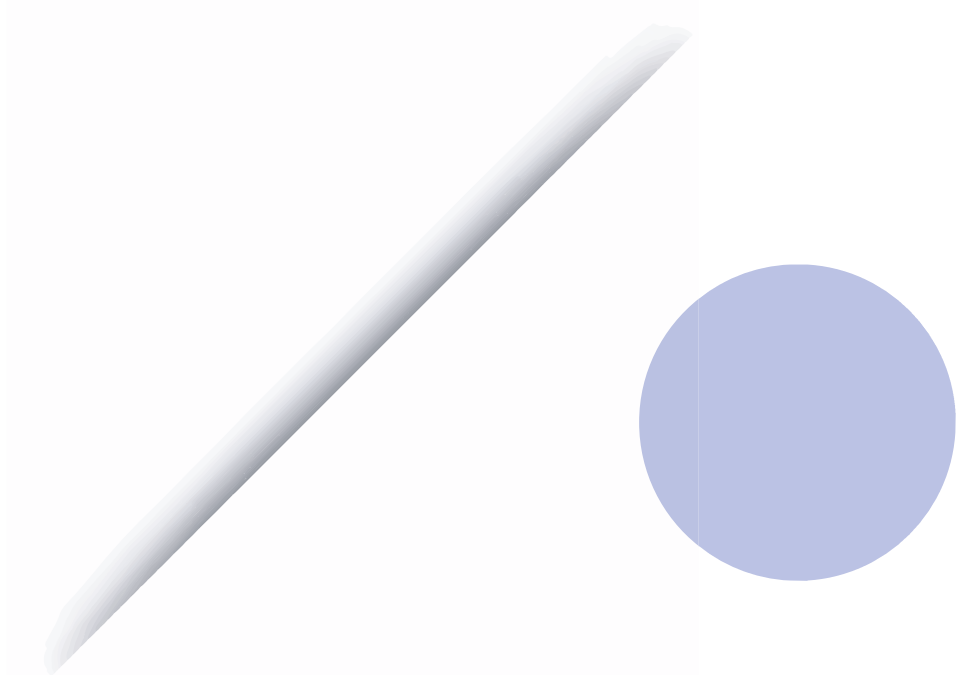



OZA-RV 300/301-040

Curve number	Number of poles	Nnom, kW	Impeller	α , deg	Current, A at 380V	Weight*, kg	Motor size
1	4	0,37	L	40	1,18	23,4	63
2				40		21,3	
3			B	45		21,3	
4				50		21,3	
5				55		21,3	

Curve number	Number of poles	Nnom, kW	Impeller	α , deg	Current, A at 380V	Weight, kg	Motor size
1	2	0,75	L	40	1,8	27,5	71
2				40		26,2	
3			B	45		29,4	
4				50		29,4	
5				L		57	

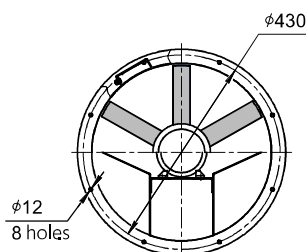
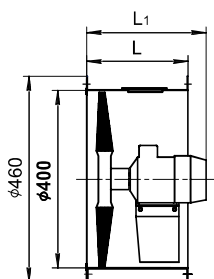
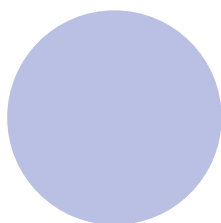
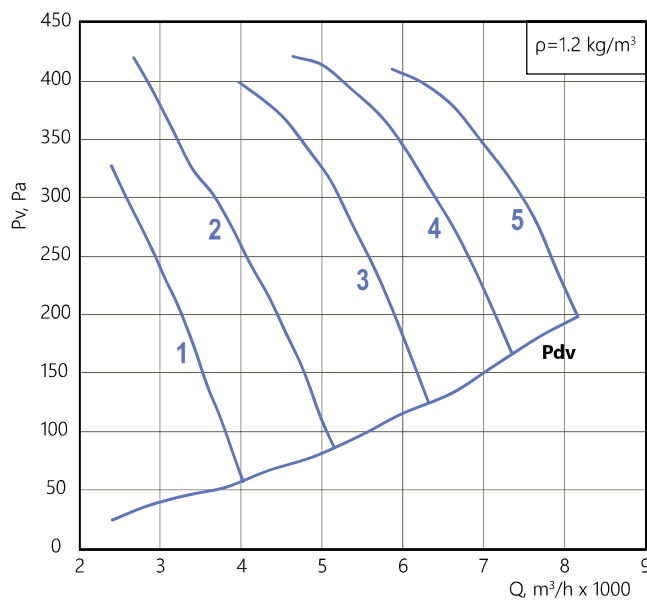
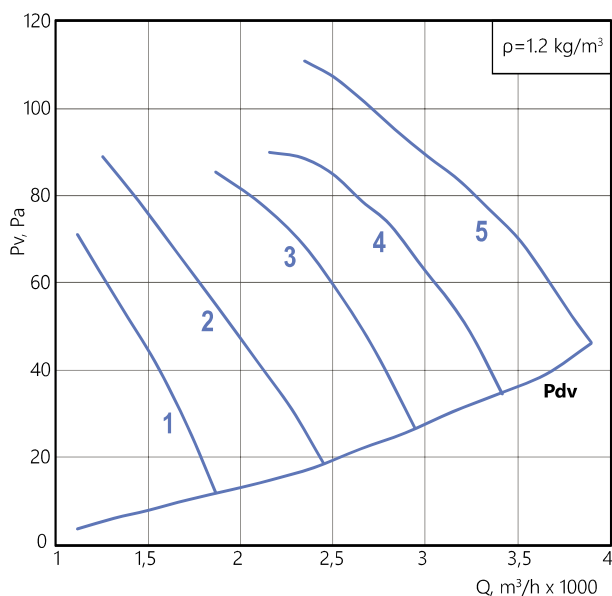

Motor size	L, mm	L1 max, mm
•63	320	380
•71 •80	370	440

NOTE:

* When changing the motor type, the weight may change.
The company reserves the right to change the size and configuration without prior notice.

ADDITIONAL EQUIPMENT

silencer OZA-GKK	inlet header OZA-VKO	flat adapter OZA-PEP	counter flange OZA-FOT	protective mesh OZA-SEM, OZA-SEB
check valve OZA-KLR	mounting support OZA-MOP	roof adapter OZA-PEK	weather protection hood OZA-ZNT	
grille OZA-R50	flexible connector OZA-COM	toroidal adapter OZA-PET	frequency converter ASC	straight section of the duct OZA-PUV
fan control cabinet SAU-PPV, SAU-SPV (up to 7.5 kW) separate cabinet for each motor				





OZA-RV 300/301-045

Curve number	Number of poles	Nnom, kW	Impeller	α, deg	Current, A at 380V	Weight*, kg	Motor size
1	4	0,37	B	45	1,18	24,2	63
2				52		24,2	
3		0,55	L	57	1,5	29,7	71
4				B		60	

Curve number	Number of poles	Nnom, kW	Impeller	α, deg	Current, A at 380V	Weight, kg	Motor size
1	2	2,2	B	45	4,6	34,4	80
2		3		50	6,5	39,9	90
3		4		55	8,4	46,9	100
4		5,5		60	11	52,4	

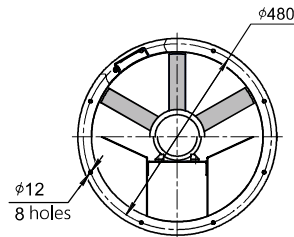
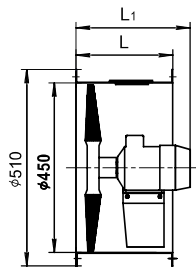
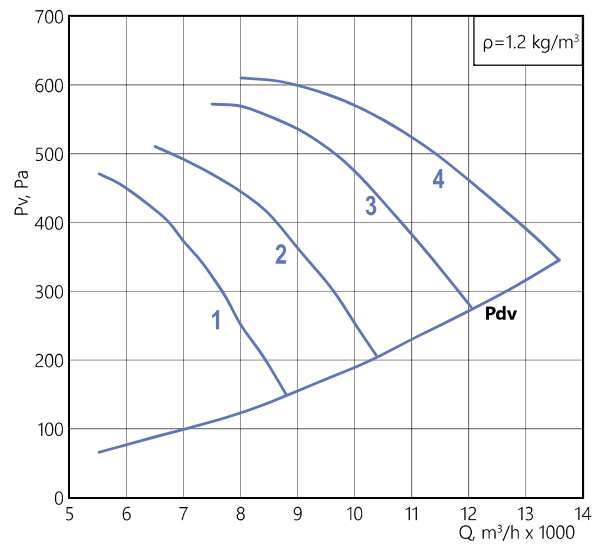
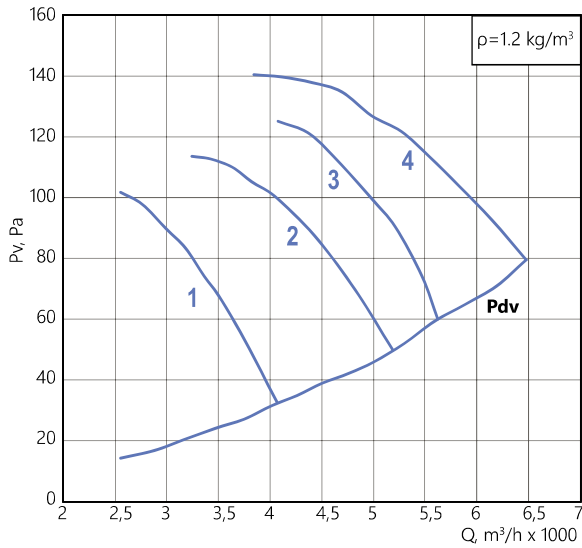

ENERGY EFFICIENT AXIAL FANS

Motor size	L, mm	L1 max, mm
•63	320	380
•71 •80	370	440
•90 •100	420	510

NOTE:

* When changing the motor type, the weight may change.
The company reserves the right to change the size and configuration without prior notice.

ADDITIONAL EQUIPMENT

silencer OZA-GKK	inlet header OZA-VKO	flat adapter OZA-PEP	counter flange OZA-FOT	protective mesh OZA-SEM, OZA-SEB
check valve OZA-KLR	mounting support OZA-MOP	roof adapter OZA-PEK	weather protection hood OZA-ZNT	
grille OZA-R50	flexible connector OZA-COM	toroidal adapter OZA-PET	frequency converter ASC	straight section of the duct OZA-PUV
fan control cabinet SAU-PPV, SAU-SPV (up to 7.5 kW) separate cabinet for each motor				

60





OZA-RV 300/301-050

Curve number	Number of poles	Nnom, kW	Impeller	α , deg	Current, A at 380V	Weight*, kg	Motor size
1	4	0,37	I	52	1,18	29,3	63
2		0,55	B	52	1,5	30,2	71
3		0,75		60	2,2	31,5	

Curve number	Number of poles	Nnom, kW	Impeller	α , deg	Current, A at 380V	Weight, kg	Motor size
1	2	2,2	B	40	4,6	37,1	80
2		3		45	6,5	42,4	90
3		4	L	52	8,4	51,7	100
4		5,5	B	55	11	54,9	
5		7,5		60	14,7	68,1	

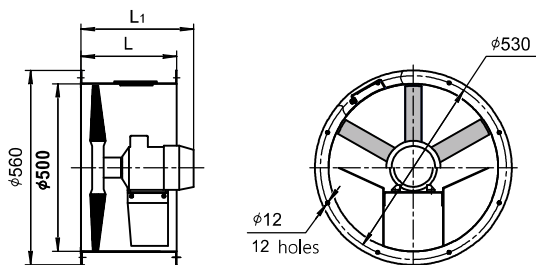
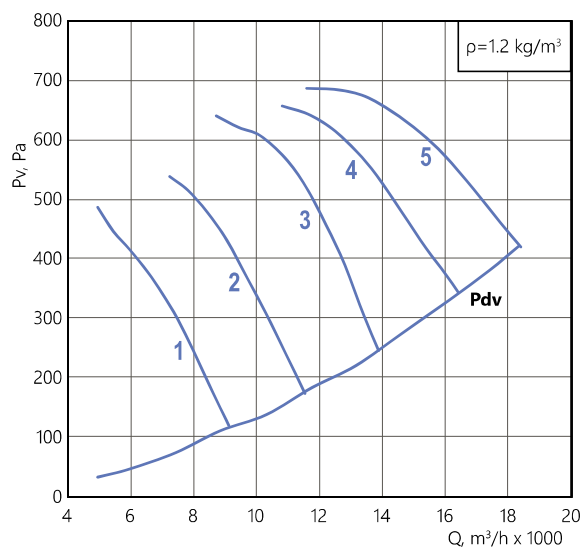
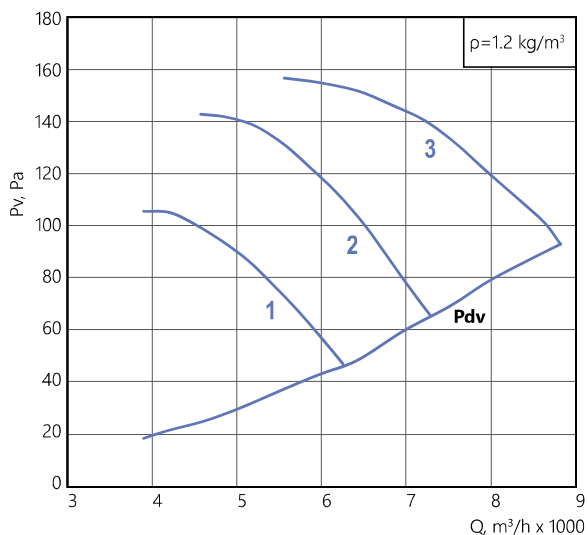

Motor size	L, mm	L1 max, mm
•63	320	380
•71	370	440
•80	370	440
•90 •100	420	510

NOTE:

* When changing the motor type, the weight may change.
The company reserves the right to change the size and configuration without prior notice.

ADDITIONAL EQUIPMENT				
silencer OZA-GKK	inlet header OZA-VKO	flat adapter OZA-PEP	counter flange OZA-FOT	protective mesh OZA-SEM, OZA-SEB
check valve OZA-KLR	mounting support OZA-MOP	roof adapter OZA-PEK	weather protection hood OZA-ZNT	
grille OZA-R50	flexible connector OZA-COM	toroidal adapter OZA-PET	frequency converter ASC	straight section of the duct OZA-PUV
fan control cabinet SAU-PPV, SAU-SPV (up to 7.5 kW) separate cabinet for each motor				





OZA-RV 300/301-056

Curve number	Number of poles	Nnom, kW	Impeller	α , deg	Current, A at 380V	Weight*, kg	Motor size
1	6	0,25	B	52	1,04	30,2	63
2				55		30,2	
3		0,37	L	60	1,31	33,4	71

Curve number	Number of poles	Nnom, kW	Impeller	α , deg	Current, A at 380V	Weight, kg	Motor size
1	4	0,55	B	50	1,5	33,5	71
2				55		39,6	
3		1,1	L	60	2,6	39,6	80

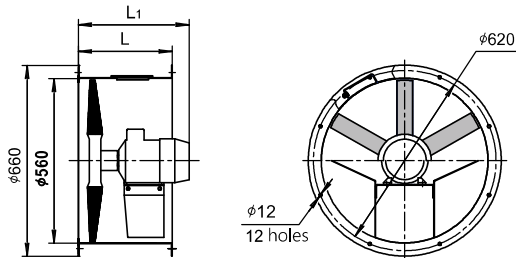
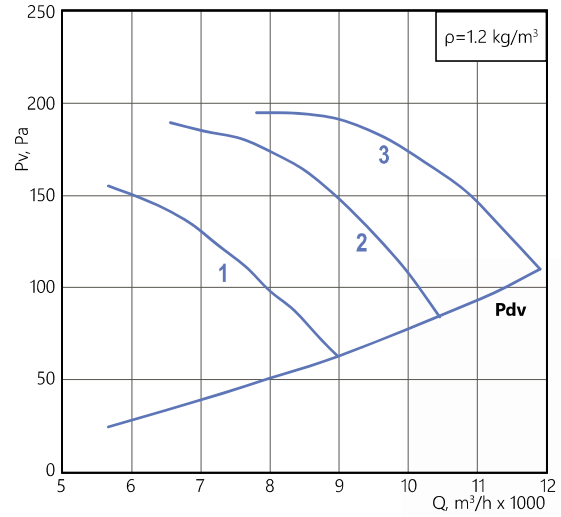
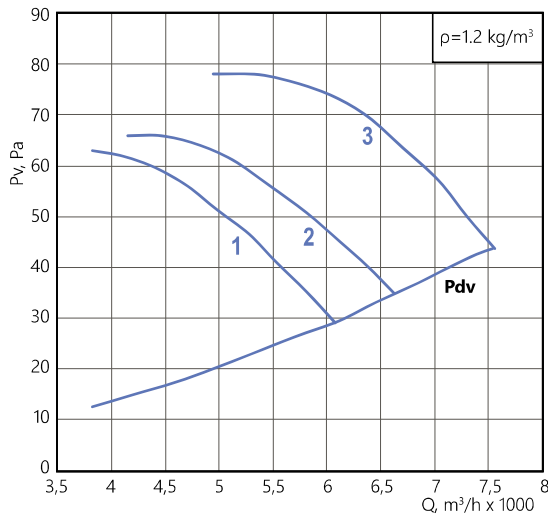

ENERGY EFFICIENT AXIAL FANS

Motor size	L, mm	L1 max, mm
•63 •71 •80	370	440
•90	420	510

NOTE:

* When changing the motor type, the weight may change.
The company reserves the right to change the size and configuration without prior notice.

ADDITIONAL EQUIPMENT

silencer OZA-GKK	inlet header OZA-VKO	flat adapter OZA-PEP	counter flange OZA-FOT	protective mesh OZA-SEM, OZA-SEB
check valve OZA-KLR	mounting support OZA-MOP	roof adapter OZA-PEK	weather protection hood OZA-ZNT	
grille OZA-R50	flexible connector OZA-COM	toroidal adapter OZA-PET	frequency converter ASC	straight section of the duct OZA-PUV
fan control cabinet SAU-PPV, SAU-SPV (up to 7.5 kW) separate cabinet for each motor				





OZA-RV 300/301-063

Curve number	Number of poles	Nnom, kW	Impeller	α , deg	Current, A at 380V	Weight*, kg	Motor size
1	6	0,25	B	52	1,04	34,1	63
2		0,37		55	1,31	36,4	71
3		0,55	L	60	1,74	40,3	

Curve number	Number of poles	Nnom, kW	Impeller	α , deg	Current, A at 380V	Weight, kg	Motor size
1	4	0,55	E	50	1,5	35,7	71
2		1,1	I	52	2,6	42,4	80
3		1,5	L	55	3,6	45,7	
4		2,2		60	5,1	51,4	90

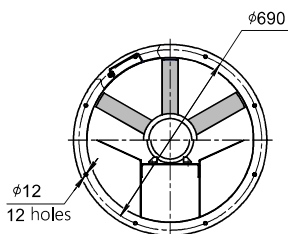
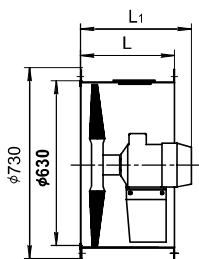
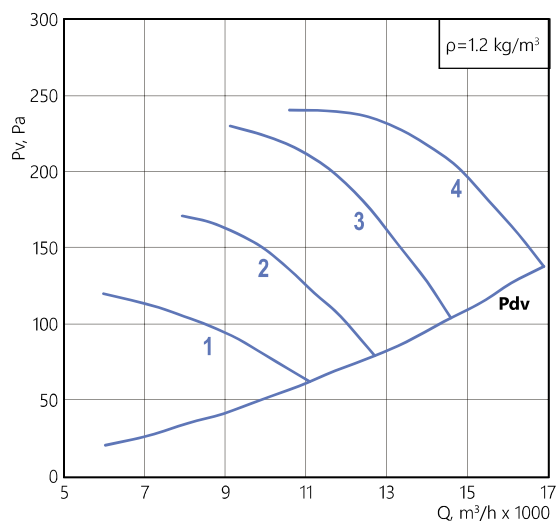
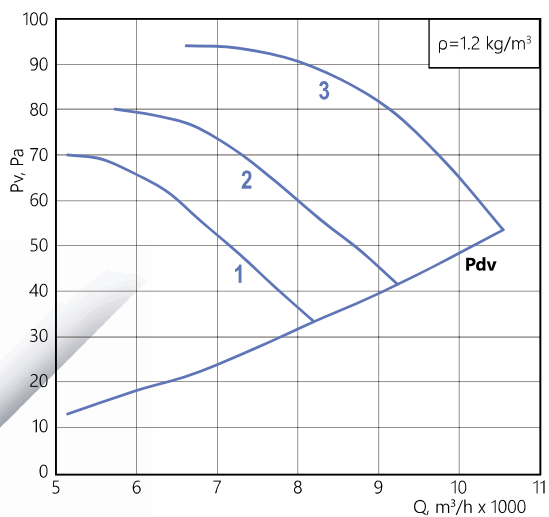

Motor size	L, mm	L1 max, mm
•63 •71 •80	370	440
•90	420	510

NOTE:

* When changing the motor type, the weight may change.
The company reserves the right to change the size and configuration without prior notice.

ADDITIONAL EQUIPMENT				
silencer OZA-GKK	inlet header OZA-VKO	flat adapter OZA-PEP	counter flange OZA-FOT	protective mesh OZA-SEM, OZA-SEB
check valve OZA-KLR	mounting support OZA-MOP	roof adapter OZA-PEK	weather protection hood OZA-ZNT	
grille OZA-R50	flexible connector OZA-COM	toroidal adapter OZA-PET	frequency converter ASC	straight section of the duct OZA-PUV
fan control cabinet SAU-PPV, SAU-SPV (up to 7.5 kW) separate cabinet for each motor				





OZA-RV 300/301-071

Curve number	Number of poles	Nnom, kW	Impeller	α , deg	Current, A at 380V	Weight*, kg	Motor size
1	6	0,37	L	50	1,31	42,9	71
2		0,55		55	1,74	44,2	
3		0,75		60	2,3	45,9	

Curve number	Number of poles	Nnom, kW	Impeller	α , deg	Current, A at 380V	Weight, kg	Motor size	
1	4	1,5	L	50	3,6	48,1	80	
2		2,2		55	5,1	55,2		90
3		3		60	7,3	60,1		

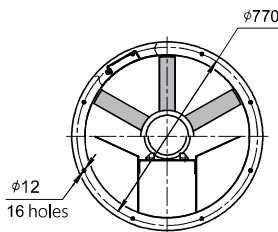
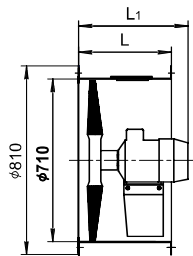
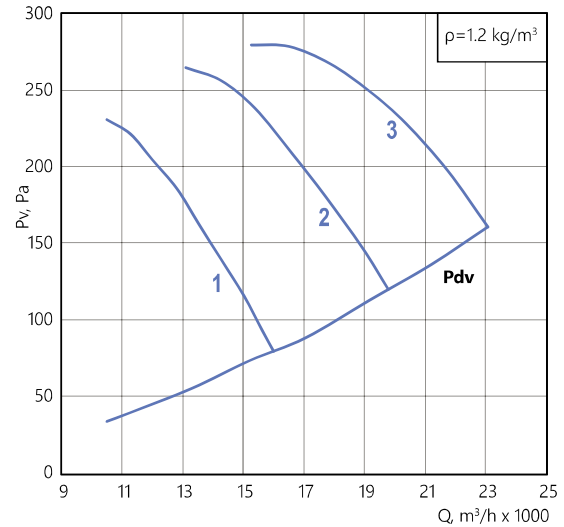
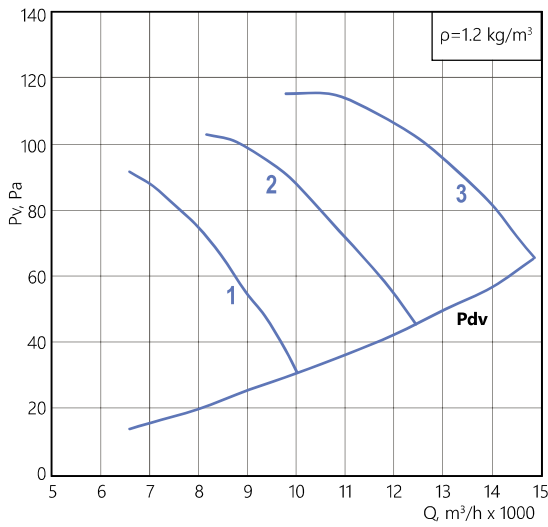

Motor size	L, mm	L1 max, mm
•71 •80	370	440
•90 •100	420	510

NOTE:

* When changing the motor type, the weight may change.
The company reserves the right to change the size and configuration without prior notice.

ADDITIONAL EQUIPMENT

silencer OZA-GKK	inlet header OZA-VKO	flat adapter OZA-PEP	counter flange OZA-FOT	protective mesh OZA-SEM, OZA-SEB
check valve OZA-KLR	mounting support OZA-MOP	roof adapter OZA-PEK	weather protection hood OZA-ZNT	
grille OZA-R50	flexible connector OZA-COM	toroidal adapter OZA-PET	frequency converter ASC	straight section of the duct OZA-PUV
fan control cabinet SAU-PPV, SAU-SPV (up to 7.5 kW) separate cabinet for each motor				





OZA-RV 300/301-080

Curve number	Number of poles	Nnom, kW	Impeller	α , deg	Current, A at 380V	Weight*, kg	Motor size
1	6	0,75	L	50	2,3	63,2	80
2		1,1		55	3,2	66,9	
3		1,5		60	4,1	74,8	

Curve number	Number of poles	Nnom, kW	Impeller	α , deg	Current, A at 380V	Weight, kg	Motor size
1	4	1,5	L	45	3,6	65,4	80
2		2,2		50	5,1	73,9	90
3		4		55	8,6	85	100
4		5,5		60	11,7	102,3	112

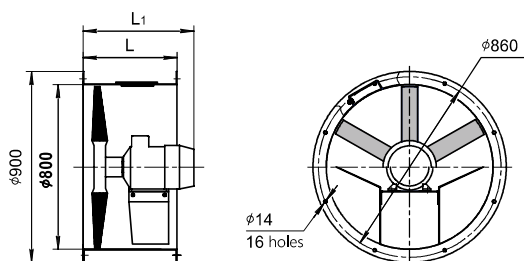
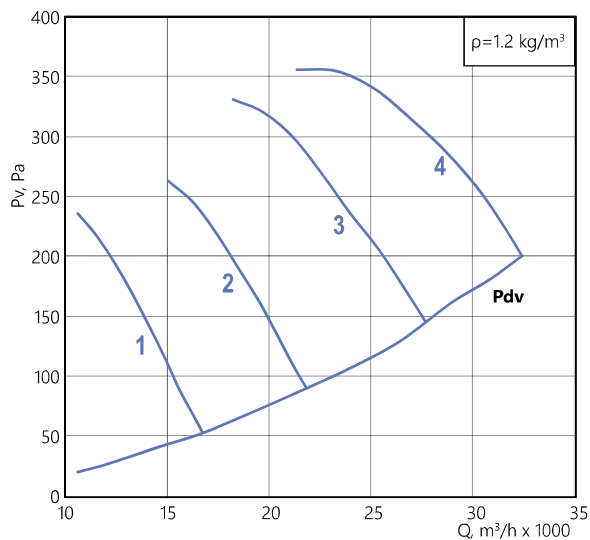
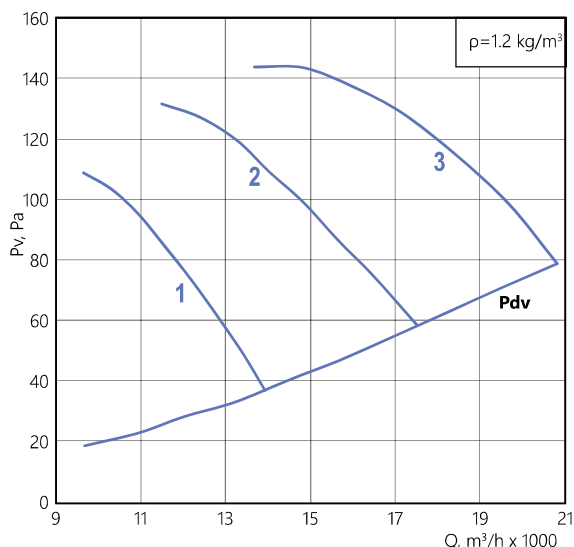

Motor size	L, mm	L1 max, mm
•80	370	440
•90 •100	420	510
•112	515	625

NOTE:

* When changing the motor type, the weight may change.
The company reserves the right to change the size and configuration without prior notice.

ADDITIONAL EQUIPMENT

silencer OZA-GKK	inlet header OZA-VKO	flat adapter OZA-PEP	counter flange OZA-FOT	protective mesh OZA-SEM, OZA-SEB
check valve OZA-KLR	mounting support OZA-MOP	roof adapter OZA-PEK	weather protection hood OZA-ZNT	
grille OZA-R50	flexible connector OZA-COM	toroidal adapter OZA-PET	frequency converter ASC	straight section of the duct OZA-PUV
fan control cabinet SAU-PPV, SAU-SPV (up to 7.5 kW) separate cabinet for each motor				





QUESTIONNAIRE

PLEASE FILL IN ALL THE NECESSARY DATA AND SEND IT TO THE NEAREST COMPANY OFFICE

AXIAL FAN

OZA-RV 300 _____

Quantity, pcs: _____

Contact person: _____

Organization: _____

Tel.: _____

e-mail: _____

City: _____

PLEASE CHECK OR SPECIFY THE REQUIRED VALUE

operation mode	efficiency Q, m ³ /h		
	pressure at t=20° C, Pa	total pressure Pv	
		static pressure Psv	
fan size			
design fan	N – general purpose industrial		
	V – explosion-proof		
	CR1 – corrosion-resistant		
	VCR1 – corrosion-resistant explosion-proof		
climatic version	Y1 (Y1)		
	Y2 (Y2)		
	YHL1 (YXJ11)		
motor	nominal power, kW		
	number of poles		
casing type	long case - 01		
	short case - 02		

Additional information

OZA-GKK silence			
OZA-KLR universal check valve			
OZA-VKO inlet header			
mounting support	OZA-MOP		
	OZA-MOB		
OZA-COM flexible connector	series		
	flange material	stainless steel	
		galvanized steel	
OZA-PEP flat adapter			
OZA-PET toroidal adapter			
OZA-PEK roof adapter			
OZA-PUV straight section of the air duct			
OZA-R50 grille			
protective mesh	OZA-SEM		
	OZA-SEB		
OZA-FOT counter flange			
OZA-ZNT weather protection hood			
FC-051 frequency converter			
SAU-PPV, SAU-SPV fan control cabinet			

Additional conditions:

Customer _____
(signature)

_____ (full name)





LOW-SPEED AXIAL FANS

OZA-HD 301

- ▶ OZA-HD series axial fans are designed for systems where it is necessary to provide the highest pressure-to-flow ratio with the smallest fan size or to minimize noise by using the fan at lower speeds;
- ▶ OZA-HD series fans have a number of advantages over other series:
 - ▶ high air capacity and high pressure are provided by the fan at low speed;
 - ▶ lower noise level;
 - ▶ compact, as it is possible to use a smaller fan size to provide the necessary air capacity at a given pressure;
 - ▶ low power consumption;
 - ▶ extended motor service life;
- ▶ fans are ideal for use in heat exchange equipment such as oil coolers, air cooling units, dry coolers and other purposes



•063 •071 •080 •090 •100 •112

OZA-HD fans consist of a specially designed impeller, an all-welded casing made of rolled sheet and an asynchronous motor placed in the air flow. Thanks to its special aerodynamic shape, the motor support stand serves as a guide apparatus.

The impeller is formed by wide rotary blades of complex shape. The blade angle is adjusted during the fan manufacturing process at the factory to achieve maximum efficiency.

The properties of the blade material allow for weight optimization, making the OZA-HD series fan impeller not only strong but also lightweight. The use of a lighter impeller increases the service life of motor bearings.

The fan casing flanges are all-rolled. This provides increased rigidity and precision, which ensures the same minimum radial clearance between the impeller blades and the casing along the perimeter of the impeller.

The case is made of carbon (design N) or stainless (design CR1) steel. By special order, it is possible to apply a protective and decorative coating on the fan casing.

Fans are made in two types of casing design: long case (01) and short case (02). The short fan casing does not completely cover the motor and characterized by light weight.

The OZA-HD series fans are compact and easy to operate and maintain, creating a low noise level during operation.

They feature power consumption and long service life.

Additional equipment is offered with options: see section "Additional equipment" of the catalog.

- ▶ ventilation and air heating systems;
- ▶ as part of heat exchange equipment;
- ▶ positive pressure ventilation systems (PD-systems);
- ▶ other sanitary and technological installations.

- ▶ general purpose industrial (N);
- ▶ corrosion-resistant (CR1);

OPERATING CONDITIONS

- ▶ ambient temperature:
 - standard -40° C to +40° C;
 - by special order from -60° C to +40° C;
- ▶ conditions for the handled air mixture are presented in Table "Environmental conditions"





EXAMPLE:

OZA-HD 301 axial fan, size 063, impeller blade angle 50°, general purpose industrial design, nominal motor power $N_{nom} = 2.2 \text{ kW}$, number of poles 4, climatic version Y1, casing type 01

OZA-HD 301-063-50-N-00220/4-Y1-01

- ▶ low-speed axial fan
- ▶ fan size (063, 071, 080, 090, 100, 112)
- ▶ impeller blade angle α , deg (50, 60, 70)
- ▶ design (•N, •CR1)
- ▶ motor parameters²: •I/P
I³ - Motor Power Index - see Table 1
P - number of Poles: 2 (3000 rpm), 4 (1500 rpm), 6 (1000 rpm), 8 (750 rpm)
- ▶ climatic version •Y1 •Y2 •YHL1
- ▶ casing type: 01 (fully enclosed casing), 02 (features minimum possible length)

NOTE:

¹By default all supplied fans are designed for 380 V, 50 Hz, direct start. Design types of other voltages and connection methods are available upon special agreement.

Special requirements for the fan are specified additionally and agreed upon with the manufacturer.

OZA-HD MOTOR POWER INDEX

Nominal power (N_{nom}), kW	0,18...0,75	1,1...7,5	11...90
Motor Power Index (I)	00018...00075	00110...00750	01100...09000

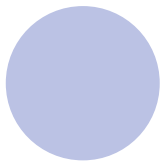



OZA-HD 301-063

Curve number	Number of poles	Nnom, kW	α , deg	Current, A at 380 V	Weight, kg		Motor size
					casing type		
					01	02	
1	6	0,55	50	1,74	42,8	38,2	71
2		1,1	60	3,2	49,7	45,1	80
3		1,5	70	4,1	55,4	50,1	90

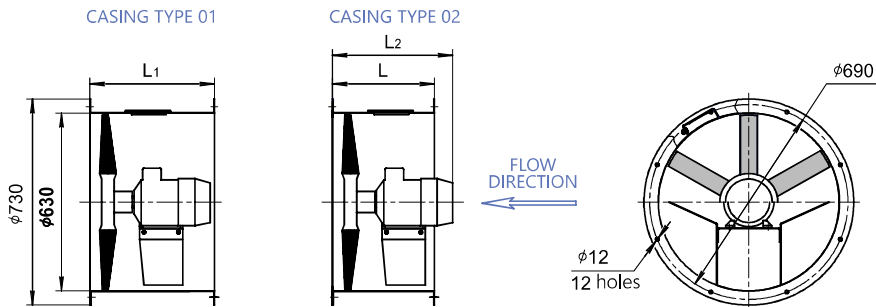
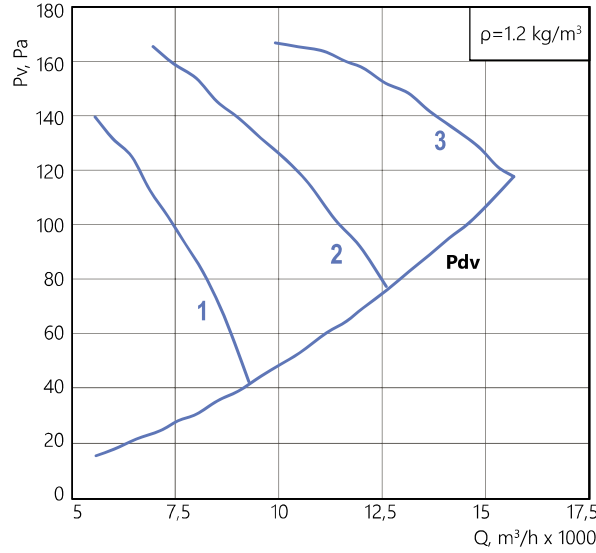

Motor size	L, mm	L1, mm	L2 max, mm
•71 •80	370	520	520

NOTE:
 * When changing the motor type, the weight may change.
 The company reserves the right to change the size and configuration without prior notice.

ADDITIONAL EQUIPMENT				
silencer OZA-GKK	inlet header OZA-VKO	flat adapter OZA-PEP	counter flange OZA-FOT	protective mesh OZA-SEM, OZA-SEB
check valve OZA-KLR	mounting support OZA-MOP	roof adapter OZA-PEK	weather protection hood OZA-ZNT	
grille OZA-R50	flexible connector OZA-COM	toroidal adapter OZA-PET	frequency converter ASC	straight section of the duct OZA-PUV
fan control cabinet SAU-PPV, SAU-SPV (up to 7.5 kW) separate cabinet for each motor				





OZA-HD 301-063

Curve number	Number of poles	Nnom, kW	α, deg	Current, A at 380 V	Weight, kg		Motor size
					casing type		
					01	02	
1	4	2,2	50	5,1	54,5	49,2	90
2		4	60	8,6	65,6	60,3	100
3		5,5	70	11,7	81,9	76	112

Curve number	Number of poles	Nnom, kW	α, deg	Current, A at 380 V	Weight, kg		Motor size
					casing type		
					01	02	
1	2	22	50	42,7	191,4	178,1	180
2		30	60	59,1	191,4	178,1	

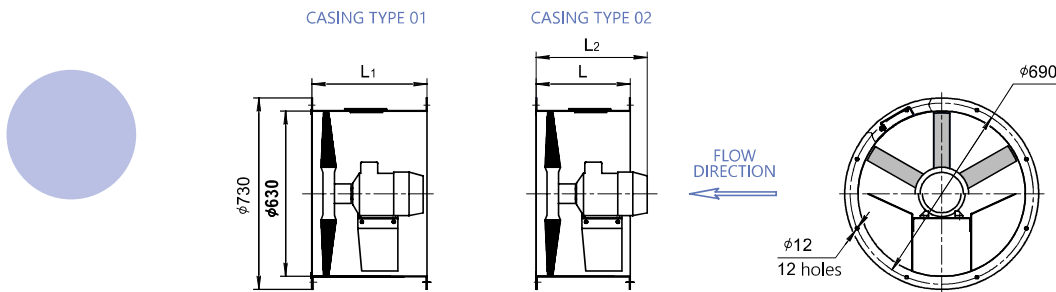
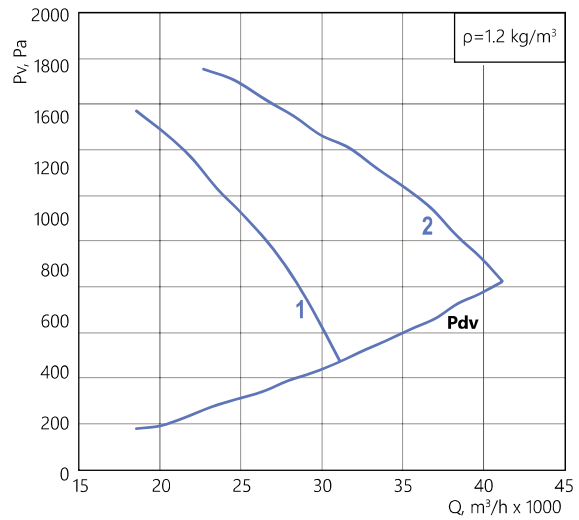
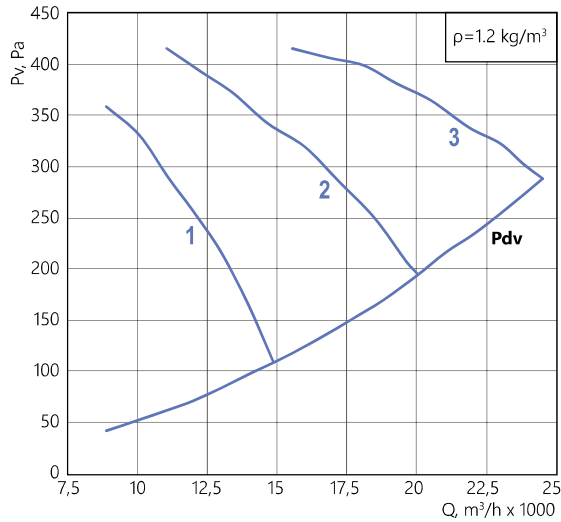

Motor size	L, mm	L1, mm	L2 max, mm
•90 •100	420	590	590
•112	515	705	705
•180	630	895	895

NOTE:

* When changing the motor type, the weight may change.
The company reserves the right to change the size and configuration without prior notice.

ADDITIONAL EQUIPMENT

silencer OZA-GKK	inlet header OZA-VKO	flat adapter OZA-PEP	counter flange OZA-FOT	protective mesh OZA-SEM, OZA-SEB
check valve OZA-KLR	mounting support OZA-MOP	roof adapter OZA-PEK	weather protection hood OZA-ZNT	
grille OZA-R50	flexible connector OZA-COM	toroidal adapter OZA-PET	frequency converter ASC	straight section of the duct OZA-PUV
fan control cabinet SAU-PPV, SAU-SPV (up to 7.5 kW) separate cabinet for each motor				



OZA-HD 301-071

Curve number	Number of poles	Nnom, kW	α, deg	Current, A at 380 V	Weight, kg		Motor size
					casing type		
					01	02	
1	8	0,55	50	2,17	55,1	49,8	80
2		0,75	60	2,43	61,5	55,6	90
3		1,1	70	3,1	64,3	58,4	

Curve number	Number of poles	Nnom, kW	α, deg	Current, A at 380 V	Weight, kg		Motor size
					casing type		
					01	02	
1	6	1,1	50	3,2	55,6	50,3	80
2		2,2	60	5,8	71,8	65,9	100
3		3	70	7	86,5	79,8	112

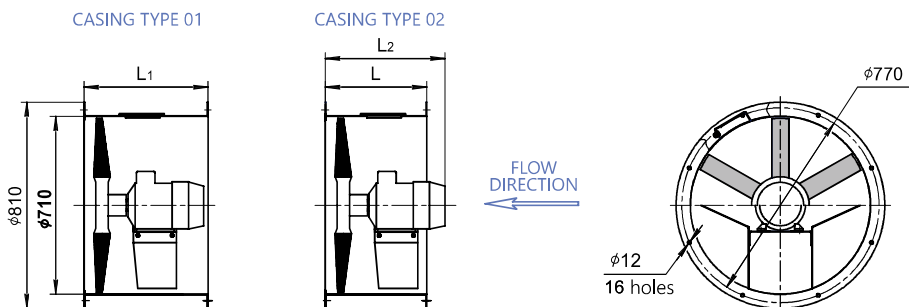
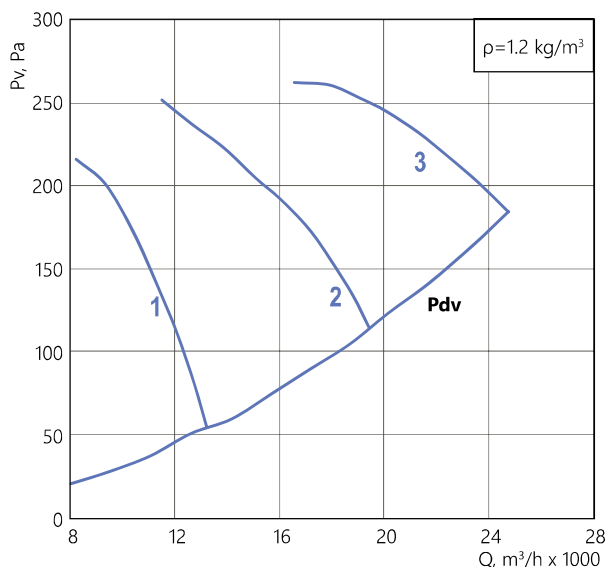
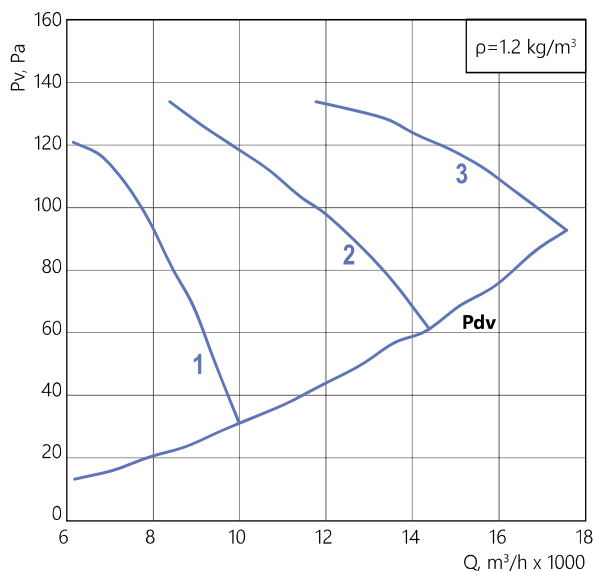

Motor size	L, mm	L1, mm	L2 max, mm
•80	370	520	520
•90 •100	420	590	590
•112	515	705	705

NOTE:
 * When changing the motor type, the weight may change.
 The company reserves the right to change the size and configuration without prior notice.

ADDITIONAL EQUIPMENT				
silencer OZA-GKK	inlet header OZA-VKO	flat adapter OZA-PEP	counter flange OZA-FOT	protective mesh OZA-SEM, OZA-SEB
check valve OZA-KLR	mounting support OZA-MOP	roof adapter OZA-PEK	weather protection hood OZA-ZNT	
grille OZA-R50	flexible connector OZA-COM	toroidal adapter OZA-PET	frequency converter ASC	straight section of the duct OZA-PUV
fan control cabinet SAU-PPV, SAU-SPV (up to 7.5 kW) separate cabinet for each motor				



OZA-HD 301-071

Curve number	Number of poles	Nnom, kW	α, deg	Current, A at 380 V	Weight, kg		Motor size
					casing type		
					01	02	
1	4	5,5	50	11,7	89,6	82,9	112
2		7,5	60	15,6	104,6	97,9	132
3		11	70	23	117,4	110,7	

Curve number	Number of poles	Nnom, kW	α, deg	Current, A at 380 V	Weight, kg		Motor size
					casing type		
					01	02	
1	2	37	50	67,9	331,6	320,6	200

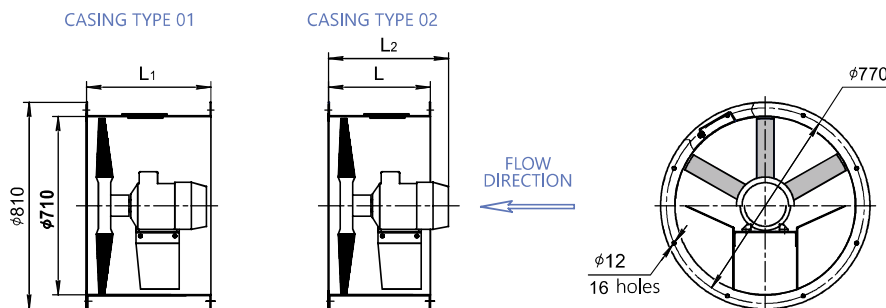
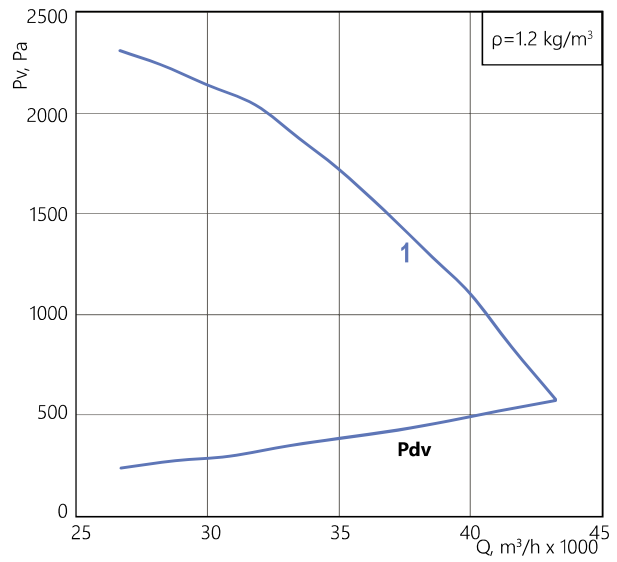
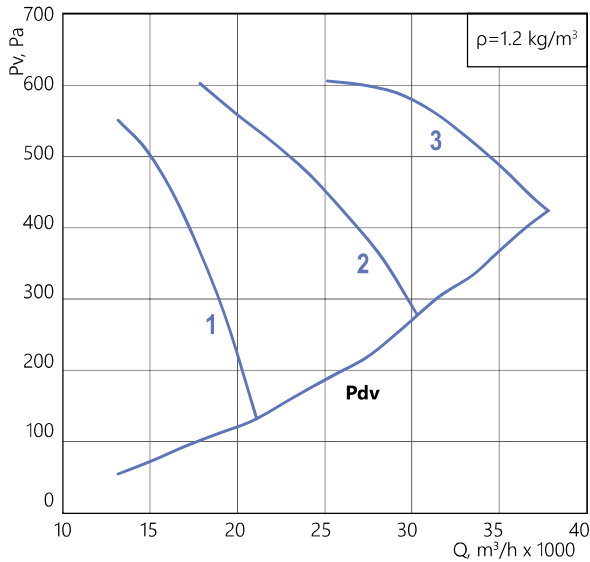

Motor size	L, mm	L1, mm	L2 max, mm
•112 •132	515	705	705
•200	820	1030	1030

NOTE:

* When changing the motor type, the weight may change.
The company reserves the right to change the size and configuration without prior notice.

ADDITIONAL EQUIPMENT				
silencer OZA-GKK	inlet header OZA-VKO	flat adapter OZA-PEP	counter flange OZA-FOT	protective mesh OZA-SEM, OZA-SEB
check valve OZA-KLR	mounting support OZA-MOP	roof adapter OZA-PEK	weather protection hood OZA-ZNT	
grille OZA-R50	flexible connector OZA-COM	toroidal adapter OZA-PET	frequency converter ASC	straight section of the duct OZA-PUV
fan control cabinet SAU-PPV, SAU-SPV (up to 7.5 kW) separate cabinet for each motor				





OZA-HD 301-080

Curve number	Number of poles	Nnom, kW	α , deg	Current, A at 380 V	Weight, kg		Motor size
					casing type		
					01	02	
1	4	7,5	50	15,6	132,6	121,1	132
2		11	60	23	145,4	133,9	
3		15	70	31	187,6	178,3	

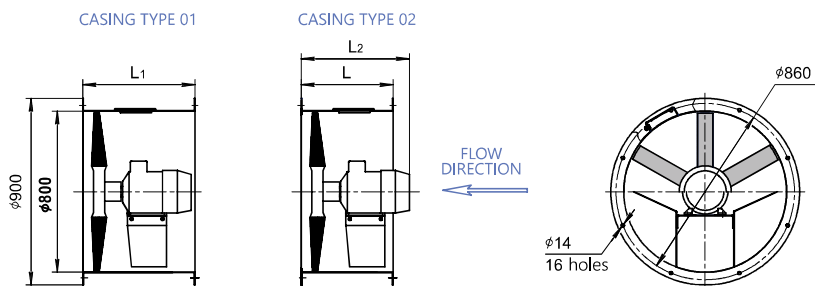
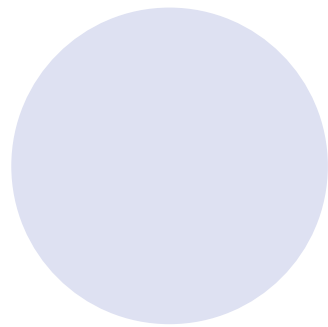
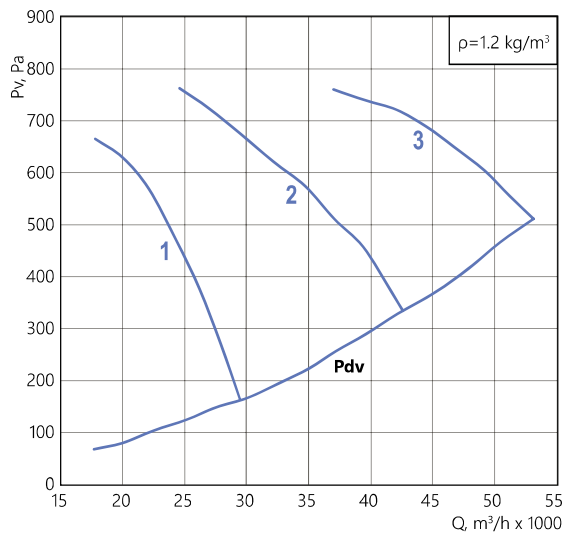

Motor size	L, mm	L1, mm	L2 max, mm
•132	515	705	705
•160	630	895	895

NOTE:

* When changing the motor type, the weight may change.
The company reserves the right to change the size and configuration without prior notice.

ADDITIONAL EQUIPMENT				
silencer OZA-GKK	inlet header OZA-VKO	flat adapter OZA-PEP	counter flange OZA-FOT	protective mesh OZA-SEM, OZA-SEB
check valve OZA-KLR	mounting support OZA-MOP	roof adapter OZA-PEK	weather protection hood OZA-ZNT	
grille OZA-R50	flexible connector OZA-COM	toroidal adapter OZA-PET	frequency converter ASC	straight section of the duct OZA-PUV
fan control cabinet SAU-PPV, SAU-SPV (up to 7.5 kW) separate cabinet for each motor				





OZA-HD 301-080

Curve number	Number of poles	Nnom, kW	α, deg	Current, A at 380 V	Weight, kg		Motor size
					casing type		
					01	02	
1	8	0,75	50	2,43	85,8	72,8	90
2		1,1	60	3,1	89,6	75,6	
3		2,2	70	6,3	113	98	

Curve number	Number of poles	Nnom, kW	α, deg	Current, A at 380 V	Weight, kg		Motor size
					casing type		
					01	02	
1	6	2,2	50	5,8	95,1	83,6	100
2		4	60	9	116,4	104,9	
3		5,5	70	12	129,9	118,4	

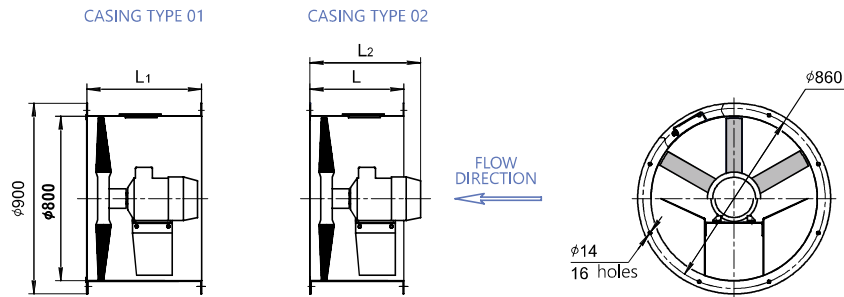
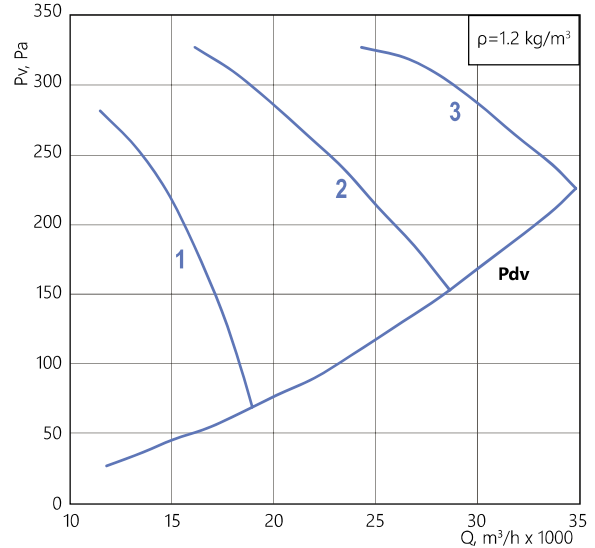
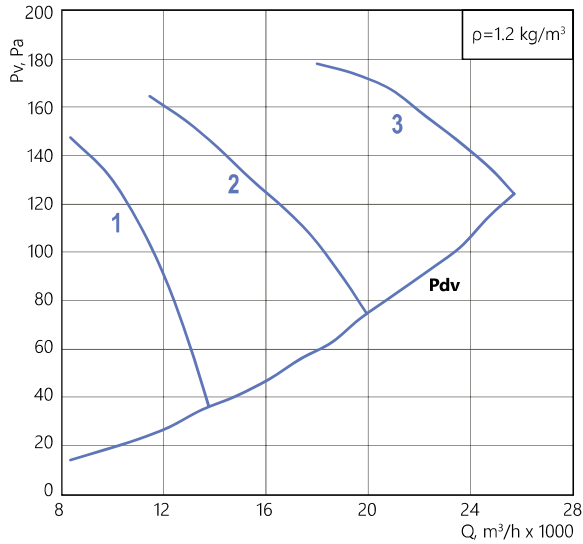

Motor size	L, mm	L1, mm	L2 max, mm
·90 ·100	420	590	590
·112 ·132	515	705	705

NOTE:

* When changing the motor type, the weight may change.
The company reserves the right to change the size and configuration without prior notice.

ADDITIONAL EQUIPMENT

silencer OZA-GKK	inlet header OZA-VKO	flat adapter OZA-PEP	counter flange OZA-FOT	protective mesh OZA-SEM, OZA-SEB
check valve OZA-KLR	mounting support OZA-MOP	roof adapter OZA-PEK	weather protection hood OZA-ZNT	
grille OZA-R50	flexible connector OZA-COM	toroidal adapter OZA-PET	frequency converter ASC	straight section of the duct OZA-PUV
fan control cabinet SAU-PPV, SAU-SPV (up to 7.5 kW) separate cabinet for each motor				

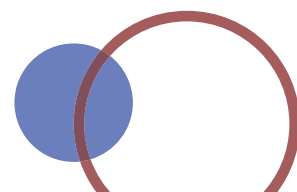



OZA-HD 301-090

Curve number	Number of poles	Nnom, kW	α, deg	Current, A at 380 V	Weight, kg		Motor size
					casing type		
					01	02	
1	4	11	50	23	154	141,3	132
2		22	60	44	221,9	204,7	180
3		30	70	56	242,9	225,7	

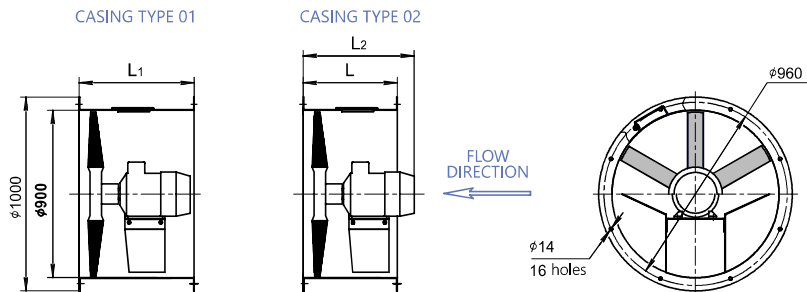
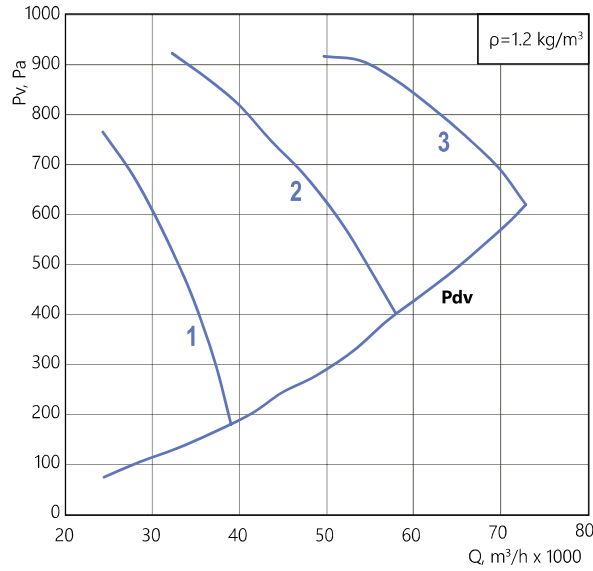

Motor size	L, mm	L1, mm	L2 max, mm
• 132	515	705	705
• 180	630	895	895

NOTE:
 * When changing the motor type, the weight may change.
 The company reserves the right to change the size and configuration without prior notice.

ADDITIONAL EQUIPMENT				
silencer OZA-GKK	inlet header OZA-VKO	flat adapter OZA-PEP	counter flange OZA-FOT	protective mesh OZA-SEM, OZA-SEB
check valve OZA-KLR	mounting support OZA-MOP	roof adapter OZA-PEK	weather protection hood OZA-ZNT	
grille OZA-R50	flexible connector OZA-COM	toroidal adapter OZA-PET	frequency converter ASC	straight section of the duct OZA-PUV
fan control cabinet SAU-PPV, SAU-SPV (up to 7.5 kW) separate cabinet for each motor				





OZA-HD 301-090

Curve number	Number of poles	Nnom, kW	α, deg	Current, A at 380 V	Weight, kg		Motor size
					casing type		
					01	02	
1	8	1,1	50	3,1	96,6	85,3	90
2		2,2	60	6,3	120,6	107,9	112
3		3	70	8	126,2	113,5	

Curve number	Number of poles	Nnom, kW	α, deg	Current, A at 380 V	Weight, kg		Motor size
					casing type		
					01	02	
1	6	3	50	7	120,6	107,9	112
2		5,5	60	12	139,5	126,8	132
3		7,5	70	17,5	151,7	139	

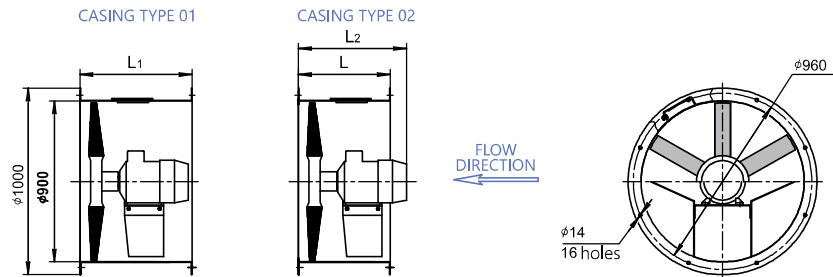
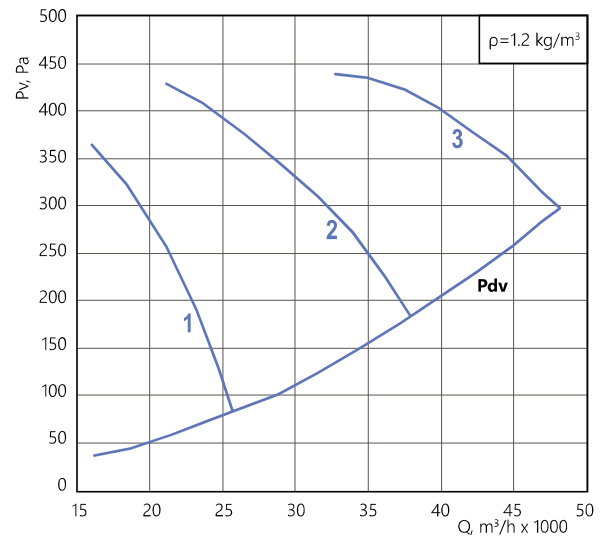
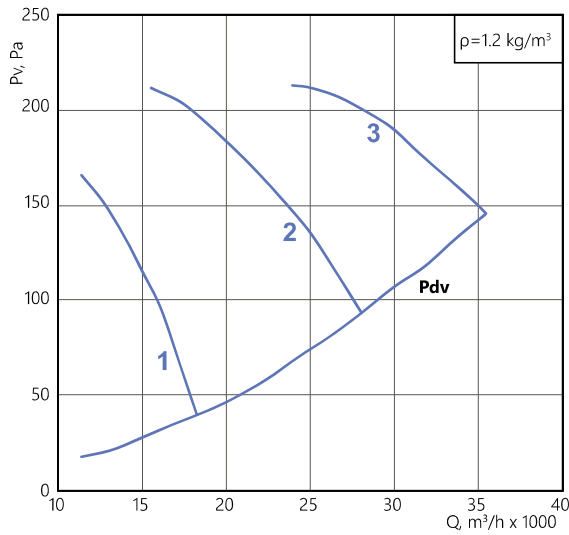

Motor size	L, mm	L1, mm	L2 max, mm
•90	420	590	590
•112 •132	515	705	705

NOTE:

* When changing the motor type, the weight may change.
The company reserves the right to change the size and configuration without prior notice.

ADDITIONAL EQUIPMENT				
silencer OZA-GKK	inlet header OZA-VKO	flat adapter OZA-PEP	counter flange OZA-FOT	protective mesh OZA-SEM, OZA-SEB
check valve OZA-KLR	mounting support OZA-MOP	roof adapter OZA-PEK	weather protection hood OZA-ZNT	
grille OZA-R50	flexible connector OZA-COM	toroidal adapter OZA-PET	frequency converter ASC	straight section of the duct OZA-PUV
fan control cabinet SAU-PPV, SAU-SPV (up to 7.5 kW) separate cabinet for each motor				





OZA-HD 301-100

Curve number	Number of poles	Nnom, kW	α, deg	Current, A at 380 V	Weight, kg		Motor size
					casing type		
					01	02	
1	4	15	50	31	226,8	207,1	160
2		30	60	56	280,6	260,9	180
3		37	70	70	408,3	392,7	200

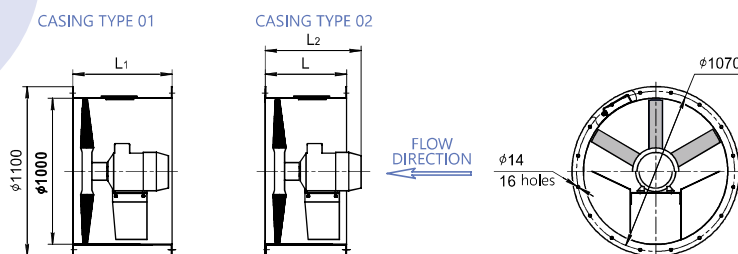
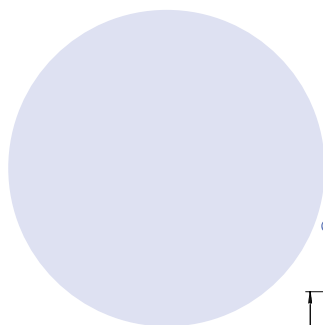
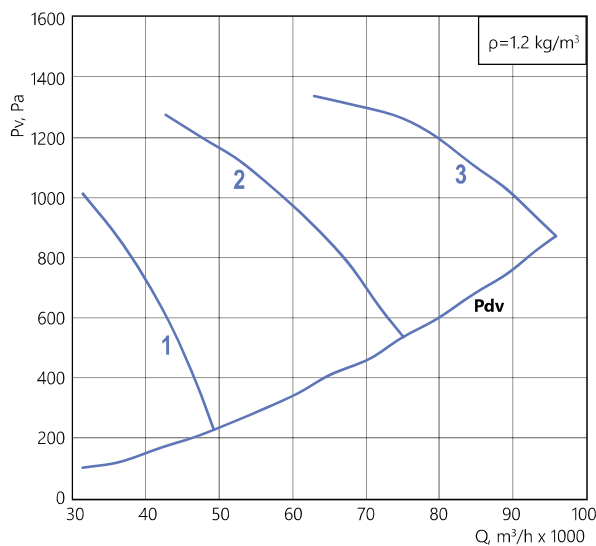

Motor size	L, mm	L1, mm	L2 max, mm
+160 +180	630	895	895
+200	820	1030	1030

NOTE:

* When changing the motor type, the weight may change.
The company reserves the right to change the size and configuration without prior notice.

ADDITIONAL EQUIPMENT				
silencer OZA-GKK	inlet header OZA-VKO	flat adapter OZA-PEP	counter flange OZA-FOT	protective mesh OZA-SEM, OZA-SEB
check valve OZA-KLR	mounting support OZA-MOP	roof adapter OZA-PEK	weather protection hood OZA-ZNT	
grille OZA-R50	flexible connector OZA-COM	toroidal adapter OZA-PET	frequency converter ASC	straight section of the duct OZA-PUV
fan control cabinet SAU-PPV, SAU-SPV (up to 7.5 kW) separate cabinet for each motor				





OZA-HD 301-100

Curve number	Number of poles	Nnom, kW	α, deg	Current, A at 380 V	Weight, kg		Motor size
					casing type		
					01	02	
1	8	1,5	50	4,6	108,4	95,8	100
2		3	60	8	134,7	120,3	112
3		5,5	70	13,6	157,9	143,5	132

Curve number	Number of poles	Nnom, kW	α, deg	Current, A at 380 V	Weight, kg		Motor size
					casing type		
					01	02	
1	6	4	50	9	134,5	120,1	112
2		7,5	60	17,5	161,2	146,8	132
3		11	70	24	230	210,3	160

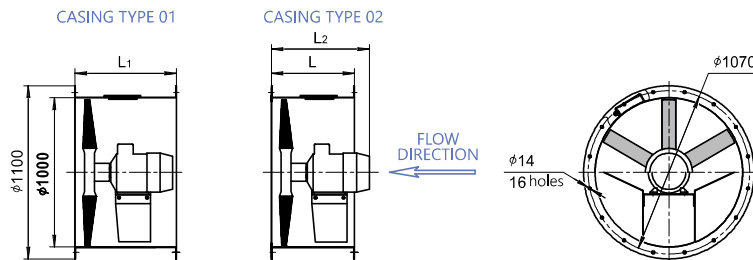
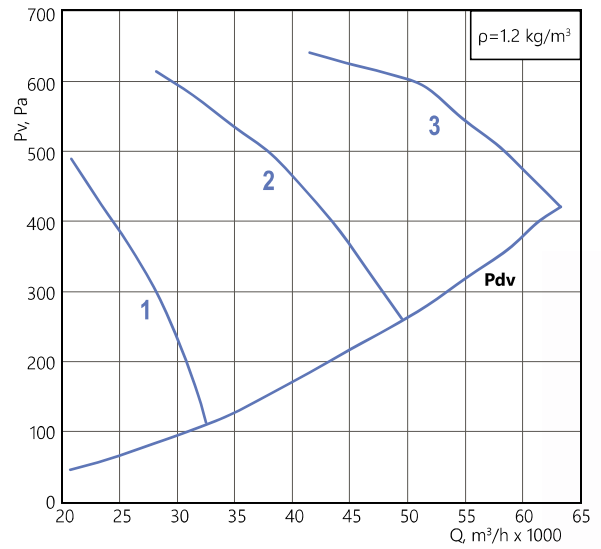
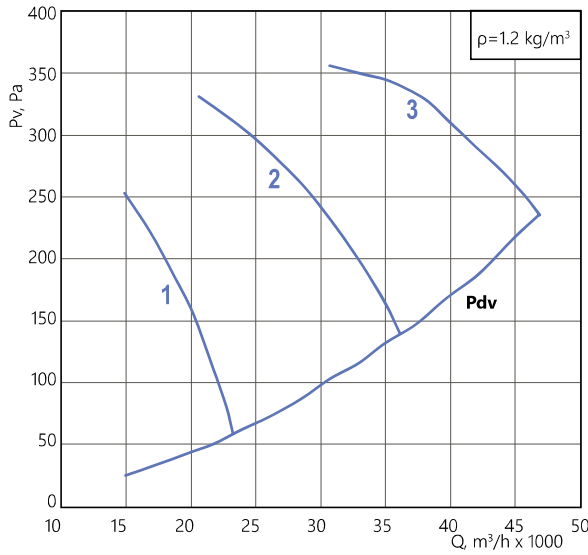

Motor size	L, mm	L1, mm	L2 max, mm
•100	420	590	590
•112 •132	515	705	705
•160	630	895	895

NOTE:

* When changing the motor type, the weight may change.
The company reserves the right to change the size and configuration without prior notice.

ADDITIONAL EQUIPMENT

silencer OZA-GKK	inlet header OZA-VKO	flat adapter OZA-PEP	counter flange OZA-FOT	protective mesh OZA-SEM, OZA-SEB
check valve OZA-KLR	mounting support OZA-MOP	roof adapter OZA-PEK	weather protection hood OZA-ZNT	
grille OZA-R50	flexible connector OZA-COM	toroidal adapter OZA-PET	frequency converter ASC	straight section of the duct OZA-PUV
fan control cabinet SAU-PPV, SAU-SPV (up to 7.5 kW) separate cabinet for each motor				





OZA-HD 301-112

Curve number	Number of poles	Nnom, kW	α, deg	Current, A at 380 V	Weight, kg		Motor size
					casing type		
					01	02	
1	4	22	50	44	279,5	257,5	180
2		37	60	70	427	407,8	200

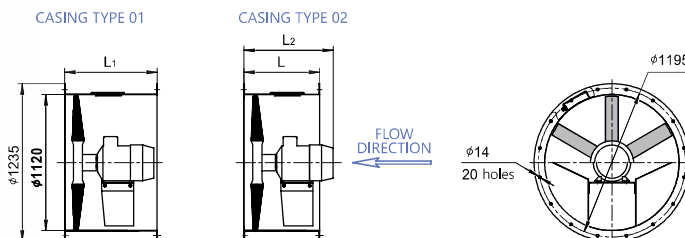
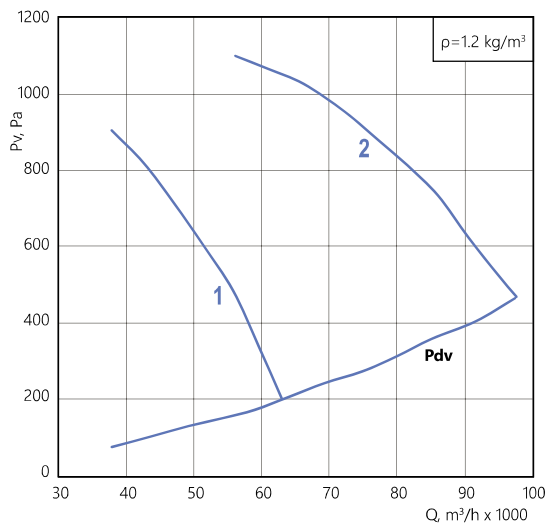

Motor size	L, mm	L1, mm	L2 max, mm
•180	630	895	895
•200	820	1030	1030

NOTE:
 * When changing the motor type, the weight may change.
 The company reserves the right to change the size and configuration without prior notice.

ADDITIONAL EQUIPMENT				
silencer OZA-GKK	inlet header OZA-VKO	flat adapter OZA-PEP	counter flange OZA-FOT	protective mesh OZA-SEM, OZA-SEB
check valve OZA-KLR	mounting support OZA-MOP	roof adapter OZA-PEK	weather protection hood OZA-ZNT	
grille OZA-R50	flexible connector OZA-COM	toroidal adapter OZA-PET	frequency converter ASC	straight section of the duct OZA-PUV
fan control cabinet SAU-PPV, SAU-SPV (up to 7.5 kW) separate cabinet for each motor				

ENERGY EFFICIENT AXIAL FANS





OZA-HD 301-112

Curve number	Number of poles	Nnom, kW	α, deg	Current, A at 380 V	Weight, kg		Motor size
					casing type		
					01	02	
1	8	2,2	50	6,3	143,2	127,5	112
2		4	60	10,5	163	147,3	132
3		7,5	70	18	235	213	160

Curve number	Number of poles	Nnom, kW	α, deg	Current, A at 380 V	Weight, kg		Motor size
					casing type		
					01	02	
1	6	5,5	50	12	162,1	146,4	132
2		11	60	24	244,4	222,4	160
3		15	70	32	260	238	160

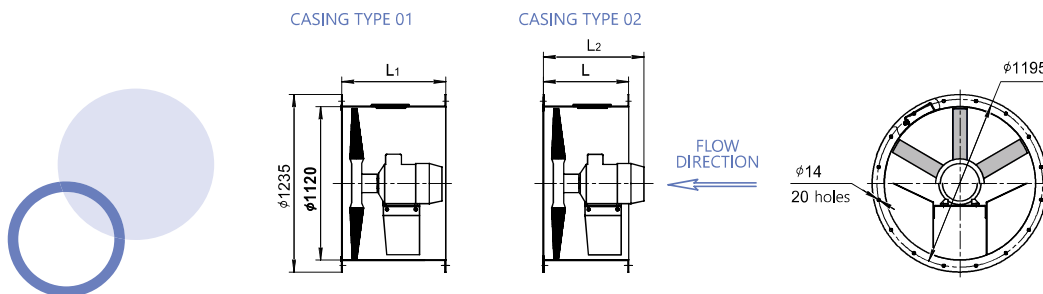
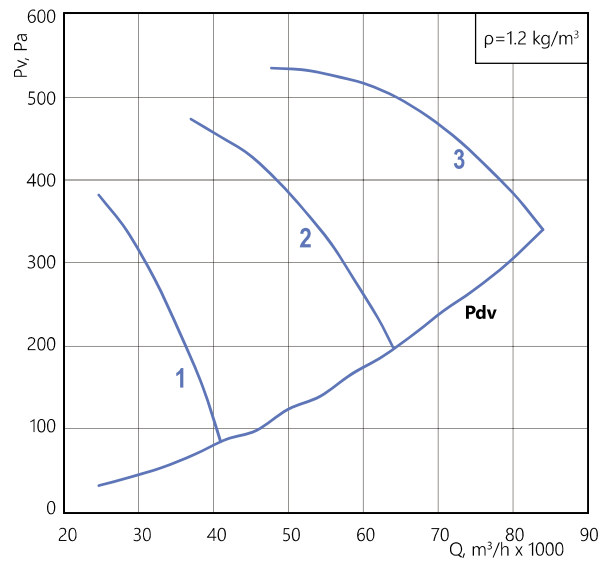
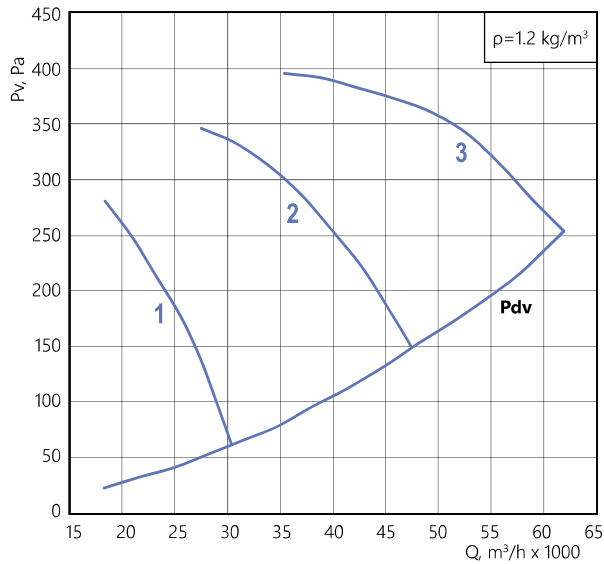

Motor size	L, mm	L1, mm	L2 max, mm
•112 •132	515	705	705
•160	630	895	895

NOTE:
 * When changing the motor type, the weight may change.
 The company reserves the right to change the size and configuration without prior notice.

ADDITIONAL EQUIPMENT				
silencer OZA-GKK	inlet header OZA-VKO	flat adapter OZA-PEP	counter flange OZA-FOT	protective mesh OZA-SEM, OZA-SEB
check valve OZA-KLR	mounting support OZA-MOP	roof adapter OZA-PEK	weather protection hood OZA-ZNT	straight section of the duct OZA-PUV
grille OZA-R50	flexible connector OZA-COM	toroidal adapter OZA-PET	frequency converter ASC	
fan control cabinet SAU-PPV, SAU-SPV (up to 7.5 kW) separate cabinet for each motor				

ENERGY EFFICIENT AXIAL FANS



QUESTIONNAIRE

PLEASE FILL IN ALL THE NECESSARY DATA AND SEND IT TO THE NEAREST COMPANY OFFICE

AXIAL FAN

OZA-HD 301

Quantity, pcs: _____

Contact person: _____

Organization: _____

Tel.: _____ e-mail: _____

City: _____

PLEASE CHECK OR SPECIFY THE REQUIRED VALUE

operation mode	efficiency Q, m ³ /h		
	pressure at t=20° C, Pa	total pressure Pv	
fan size		static pressure Psv	
design fan	N – general purpose industrial		
	V – explosion-proof		
	CR1 – corrosion-resistant		
	VCR1 – corrosion-resistant explosion-proof		
climatic version	Y1 (Y1)		
	Y2 (Y2)		
	YHL1 (УХЛ1)		
motor	nominal power, kW		
	number of poles		
casing type	long case - 01		
	short case - 02		

Additional information

OZA-GKK silence			
OZA-KLR universal check valve			
OZA-VKO inlet header			
mounting support	OZA-MOP		
	OZA-MOB		
OZA-COM flexible connector	series		
	flange material	stainless steel	
		galvanized steel	
OZA-PEP flat adapter			
OZA-PET toroidal adapter			
OZA-PEK roof adapter			
OZA-PUV straight section of the air duct			
OZA-R50 grille			
protective mesh	OZA-SEM		
	OZA-SEB		
OZA-FOT counter flange			
OZA-ZNT weather protection hood			
FC-051 frequency converter			
SAU-PPV, SAU-SPV fan control cabinet			

Additional conditions:

Customer _____
(signature)

_____ (full name)



ADDITIONAL EQUIPMENT

SILENCER | OZA-GKK

► OZA-GKK axial fan silencers are designed for direct connection to the fan inlet and outlet.



•040 •045 •050 •056 •063 •071 •080 •090 •100 •112 •125

These silencers provide a high degree of sound and noise reduction in the ventilation duct. The modification with an additional acoustic cassette improves the aerodynamic characteristics of the fan, ensuring the restoration of static pressure.

The acoustic cassette has almost the same diameter as the fan hub and, thus, provides an air channel that reduces the pressure drop in the system. The design of the OZA-GKK silencer ensures reliable operation at high fan speeds.

OZA-GKK-063-ZS

- silencer
- OZA fan size (•040 •045 •050 •056 •063 •071 •080 •090 •100 •112 •125)
- material (•C – St3 steel; •NS – stainless steel; •ZS – galvanized steel)

ENERGY EFFICIENT AXIAL FANS

ADDITIONAL EQUIPMENT

mounting support
OZA-MOB

protective mesh
OZA-SEM





OZA-GKK

SILENCER WITHOUT ADDITIONAL ACOUSTIC CASSETTE

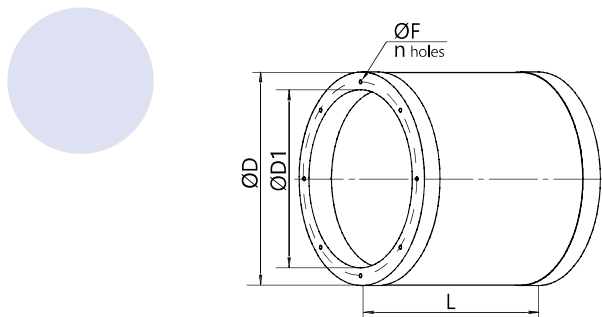

STANDARD SIZE	040	045	050	056	063	071	080	090	100	112	125
L, mm	400	450	500	560	630	710	800	900	1000	1120	1250
D, mm	600	650	700	760	830	910	1000	1100	1200	1320	1450
D1, mm	400	450	500	560	630	710	800	900	1000	1120	1250
n, mm	8	8	12	12	12	16	16	16	16	20	20
F, mm	M10	M10	M10	M10	M10	M10	M10	M12	M12	M12	M12
Weight, kg	16	20	23	25	30	34	73	92	111	143	188

OZA-GKK-L

EXTENDED SILENCER WITHOUT ADDITIONAL ACOUSTIC CASSETTE

STANDARD SIZE	040	045	050	056	063	071	080	090	100	112	125
L, mm	800	900	1000	1120	1260	1420	1600	1800	2000	2240	2400
D, mm	600	650	700	760	830	910	1000	1100	1200	1320	1450
D1, mm	400	450	500	560	630	710	800	900	1000	1120	1250
n, mm	8	8	12	12	12	16	16	16	16	20	20
F, mm	M10	M10	M10	M10	M10	M10	M10	M12	M12	M12	M12
Weight, kg	30	38	42	47	56	63	133	166	203	261	343

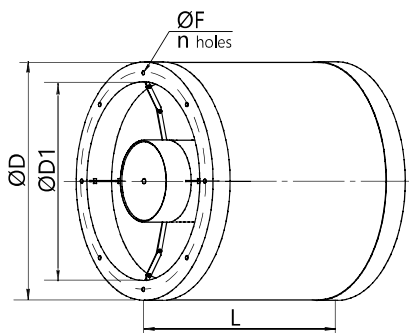

OZA-GKK-K

SILENCER WITH OPTIONAL ACOUSTIC CASSETTE

STANDARD SIZE	040	045	050	056	063	071	080	090	100	112	125
L, mm	400	450	500	560	630	710	800	900	1000	1120	1250
D, mm	600	650	700	760	830	910	1000	1100	1200	1320	1450
D1, mm	400	450	500	560	630	710	800	900	1000	1120	1250
n, mm	8	8	12	12	12	16	16	16	16	20	20
F, mm	M10	M10	M10	M10	M10	M10	M10	M12	M12	M12	M12
Weight, kg	23	30	33	37	44	50	105	132	160	206	269

OZA-GKK-KL

EXTENDED SILENCER WITH OPTIONAL ACOUSTIC CASSETTE

STANDARD SIZE	040	045	050	056	063	071	080	090	100	112	125
L, mm	800	900	1000	1120	1260	1420	1600	1800	2000	2240	2400
D, mm	600	650	700	760	830	910	1000	1100	1200	1320	1450
D1, mm	400	450	500	560	630	710	800	900	1000	1120	1250
n, mm	8	8	12	12	12	16	16	16	16	20	20
F, mm	M10	M10	M10	M10	M10	M10	M10	M12	M12	M12	M12
Weight, kg	43	55	61	68	80	91	191	241	291	373	490





AERODYNAMIC CHARACTERISTICS

OZA-GKK

SILENCER WITHOUT ADDITIONAL ACOUSTIC CASSETTE

STANDARD SIZE	125	250	500	1K	2K	4K	8K
OZA-GKK-040	-2	-3	-5	-7	-9	-6	-5
OZA-GKK-045	-2	-3	-6	-7	-8	-6	-5
OZA-GKK-050	-2	-3	-6	-8	-8	-6	-4
OZA-GKK-056	-2	-4	-7	-8	-8	-5	-4
OZA-GKK-063	-2	-4	-8	-9	-8	-5	-4
OZA-GKK-071	-3	-5	-8	-9	-7	-5	-4
OZA-GKK-080	-3	-5	-9	-8	-7	-4	-3
OZA-GKK-090	-3	-6	-9	-8	-6	-4	-2
OZA-GKK-100	-3	-6	-9	-8	-6	-4	-2
OZA-GKK-112	-4	-6	-9	-7	-6	-3	-2
OZA-GKK-125	-4	-7	-9	-7	-5	-3	-2

OZA-GKK-L

EXTENDED SILENCER WITHOUT ADDITIONAL ACOUSTIC CASSETTE

STANDARD SIZE	125	250	500	1K	2K	4K	8K
OZA-GKK-L-040	-3	-3	-7	-13	-14	-12	-8
OZA-GKK-L-045	-3	-4	-8	-13	-14	-11	-7
OZA-GKK-L-050	-3	-4	-10	-14	-13	-10	-7
OZA-GKK-L-056	-3	-5	-12	-14	-13	-10	-7
OZA-GKK-L-063	-3	-6	-13	-15	-13	-9	-6
OZA-GKK-L-071	-4	-6	-13	-15	-12	-9	-6
OZA-GKK-L-080	-4	-8	-14	-14	-11	-8	-5
OZA-GKK-L-090	-5	-10	-15	-14	-10	-6	-3
OZA-GKK-L-100	-6	-11	-15	-14	-10	-6	-3
OZA-GKK-L-112	-6	-11	-15	-13	-10	-6	-3
OZA-GKK-L-125	-6	-12	-15	-12	-9	-5	-3

NOTE: the pressure drop is negligible.

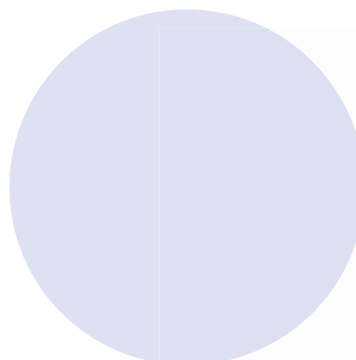



OZA-GKK-K

SILENCER WITH OPTIONAL ACOUSTIC CASSETTE

STANDARD SIZE	125	250	500	1K	2K	4K	8K	K
OZA-GKK-K-040	-3	-7	-14	-18	-16	-11	-8	8,2
OZA-GKK-K-045	-4	-7	-15	-18	-16	-11	-8	6,2
OZA-GKK-K-050	-4	-8	-15	-19	-15	-11	-8	4,0
OZA-GKK-K-056	-5	-8	-16	-21	-14	-11	-8	2,7
OZA-GKK-K-063	-5	-8	-16	-21	-14	-11	-8	1,5
OZA-GKK-K-071	-6	-9	-17	-20	-14	-11	-9	0,9
OZA-GKK-K-080	-6	-9	-18	-18	-14	-11	-9	0,55
OZA-GKK-K-090	-7	-10	-19	-17	-15	-11	-10	0,31
OZA-GKK-K-100	-7	-11	-19	-17	-14	-11	-10	0,22
OZA-GKK-K-112	-8	-12	-20	-17	-13	-11	-10	0,13
OZA-GKK-K-125	-8	-12	-20	-17	-13	-11	-10	0,08

NOTE:

pressure drop (Pa) = $K \times Q^2$,
 where **K** is the coefficient indicated in the table, **Q** is the air flow rate (m³/s)

OZA-GKK-KL

EXTENDED SILENCER WITH OPTIONAL ACOUSTIC CASSETTE

STANDARD SIZE	125	250	500	1K	2K	4K	8K	K
OZA-GKK-KL-040	-6	-11	-24	-29	-27	-20	-15	8,2
OZA-GKK-KL-045	-6	-12	-24	-30	-27	-21	-15	6,2
OZA-GKK-KL-050	-7	-12	-25	-32	-26	-21	-17	4,0
OZA-GKK-KL-056	-8	-13	-26	-34	-25	-22	-18	2,7
OZA-GKK-KL-063	-8	-13	-26	-34	-25	-22	-18	1,5
OZA-GKK-KL-071	-9	-14	-27	-32	-25	-21	-18	0,9
OZA-GKK-KL-080	-10	-15	-29	-30	-25	-20	-17	0,55
OZA-GKK-KL-090	-11	-16	-31	-29	-25	-20	-17	0,31
OZA-GKK-KL-100	-12	-17	-32	-29	-23	-19	-17	0,22
OZA-GKK-KL-112	-14	-18	-33	-29	-22	-18	-16	0,13
OZA-GKK-KL-125	-14	-18	-33	-29	-22	-18	-16	0,081

NOTE:

pressure drop (Pa) = $K \times Q^2$,
 where **K** is the coefficient indicated in the table, **Q** is the air flow rate (m³/s)





UNIVERSAL CHECK VALVE | OZA-KLR

- ▶ the standard universal check valve is designed to automatically close the air duct cross-section in order to prevent free air flow in ventilation systems when the axial fan is not operating;
- ▶ OZA-KLR valves are gravitational valves: the flaps of such valves open under the action of the air flow (the air speed in the cross-section on horizontal sections should be at least 6 m/s, on vertical sections – at least 4 m/s) and automatically return to the original closed position when the air supply is stopped;
- ▶ the valves consist of a solid-rolled round body and a simple metal sheet flap, also made of galvanized steel;
- ▶ the main difference of OZA-KLR valves is the reinforced casing, which allows withstanding short-term power loads, and is additionally protected from possible distortions during installation. On the side surface, it is possible to adjust the counterweight to ensure that the valve can be adjusted during installation depending on the installation plane, which allows such valves to remain operational regardless of spatial orientation.



- ▶ general purpose industrial (N);
- ▶ corrosion-resistant (CR);
- ▶ explosion-proof (V).

•040 •045 •050 •056 •063 •071 •080 •090 •100 •112 •125

INTENDED USE	check valve (flap-type)
OPERATING PRESSURE	up to 800 Pa
AIR FLOW RATE:	
- on vertical sections	4..12 m/s
- on horizontal sections	6..12 m/s
LEAKAGE LEVEL	0 (no requirement)
SPATIAL ORIENTATION	any possible
CLIMATIC VERSION	YHL, placement category • 2 • 3
THERMAL CONDUCTIVITY	no requirement

ENERGY EFFICIENT AXIAL FANS

OZA-KLR-050-N

- ▶ universal check valve
- ▶ OZA fan size (•040 •045 •050 •056 •063 •071 •080 •090 •100 •112 •125)
- ▶ design (• N - general purpose industrial; • CR - corrosion-resistant • V -explosion-proof)



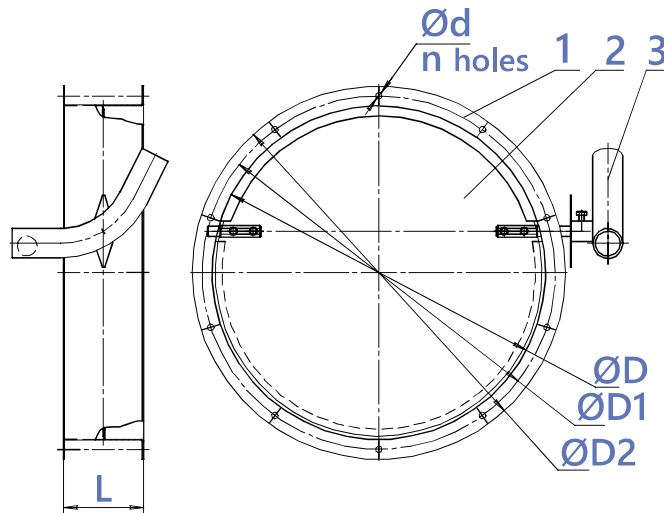

1- casing; 2 - flap; 3 - counterweight

GENERAL PURPOSE INDUSTRIAL AND CORROSION-RESISTANT DESIGN

STANDARD SIZE	D, mm	D1, mm	D2, mm	L, mm	d, mm	n	Weight, kg
OZA-KLR-040	400	430	460	120	Ø10	8	6
OZA-KLR-045	450	480	510				6,6
OZA-KLR-050	500	530	560				7,2
OZA-KLR-056	560	620	660	300	Ø12	12	11
OZA-KLR-063	630	690	730				15,2
OZA-KLR-071	710	770	810				18,7
OZA-KLR-080	800	860	900				21,8
OZA-KLR-090	900	960	1000				25
OZA-KLR-100	1000	1070	1100	20	Ø14	20	29,7
OZA-KLR-112	1120	1195	1235				34,1
OZA-KLR-125	1250	1320	1365				39,1

EXPLOSION-PROOF DESIGN

STANDARD SIZE	D, mm	D1, mm	D2, mm	L, mm	d, mm	n	Weight, kg		
OZA-KLR-040	400	430	460	385	Ø10	8	9,7		
OZA-KLR-045	450	480	510	435			11,3		
OZA-KLR-050	500	530	560	485			13,2		
OZA-KLR-056	560	620	660	545	Ø12	12	16,3		
OZA-KLR-063	630	690	730	615			23,1		
OZA-KLR-071	710	770	810	695			29,5		
OZA-KLR-080	800	860	900	785			16	16	36,6
OZA-KLR-090	900	960	1000	885					44,9
OZA-KLR-100	1000	1070	1100	985	55,5				
OZA-KLR-112	1120	1195	1235	1105	Ø14	20	68,5		
OZA-KLR-125	1250	1320	1365	1105			77,5		

ENERGY EFFICIENT AXIAL FANS





MOUNTING SUPPORT

OZA-MOP, OZA-MOB

- the OZA-MOP mounting support is used to install the fan in a horizontal position.
- the mounting support (large) of the OZA-MOV is used to install the fan in a horizontal position, with the OZA-KVO installed.

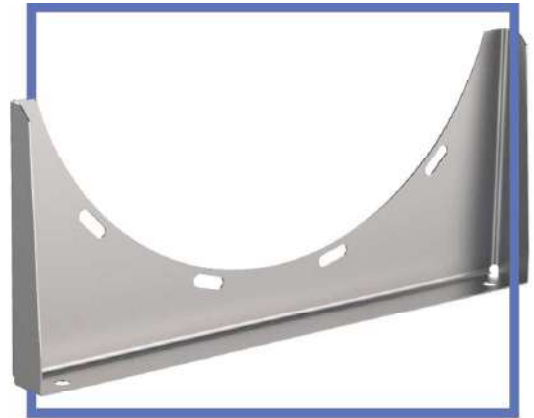

•040 •045 •050 •056 •063 •071 •080 •090 •100 •112 •125

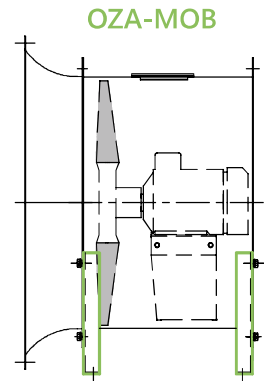
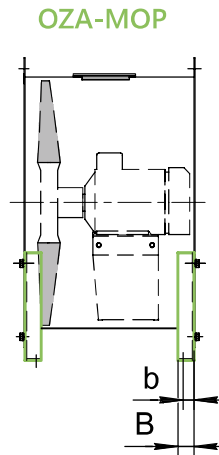
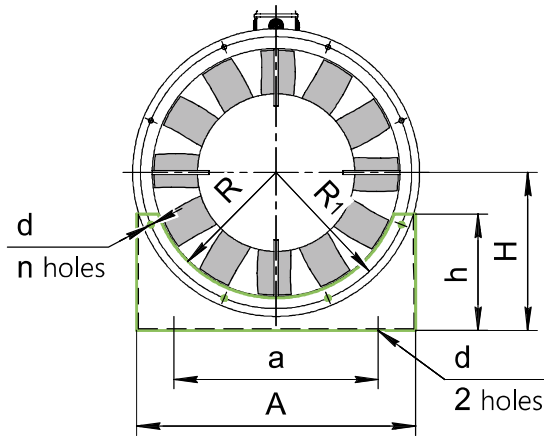

STANDARD SIZE	040	045	050	056	063	071	080	090	100	112	125	
A, mm	430	480	440	500	550	690	760	860	960	1100	1220	
a, mm	270	310	340	400	420	520	560	700	800	900	1000	
B, mm							50			57		
b, mm							25			30		
h, mm	OZA-MOP	203	223	196	236	185	260	280	345	360	470	
	OZA-MOB	253	273	246	286	235	330	375	445	460	520	
H, mm	OZA-MOP	270	300	330	380	380	420	465	520	575	700	
	OZA-MOB	320	350	380	430	430	490	560	620	675	750	
d, mm					12				14			
n	4				6				8			
R, mm	205	230	255	285	323	363	408	458	508	568	633	
R1, mm	215	240	265	310	345	385	430	480	535	597,5	660	
Weight, kg	OZA-MOP	1,2	1,4	1,3	1,8	2,2	3,2	3,6	4,4	5,3	8,1	
	OZA-MOB	1,6	1,9	1,7	2,2	3	4,5	5,5	6,6	7,8	10,5	

OZA-MOP-063-NS

- mounting frame
- OZA fan size
(•040 •045 •050 •056 •063 •071 •080 •090 •100 •112 •125)
- material (•NS - stainless steel •ZS - galvanized steel)





OZA-FOT COUNTER FLANGE



the OZA-FOT counter flange is used to connect the fan inlet or outlet to the air ducts by on-site welding.

•040 •045 •050 •056 •063 •071 •080 •090 •100 •112 •125

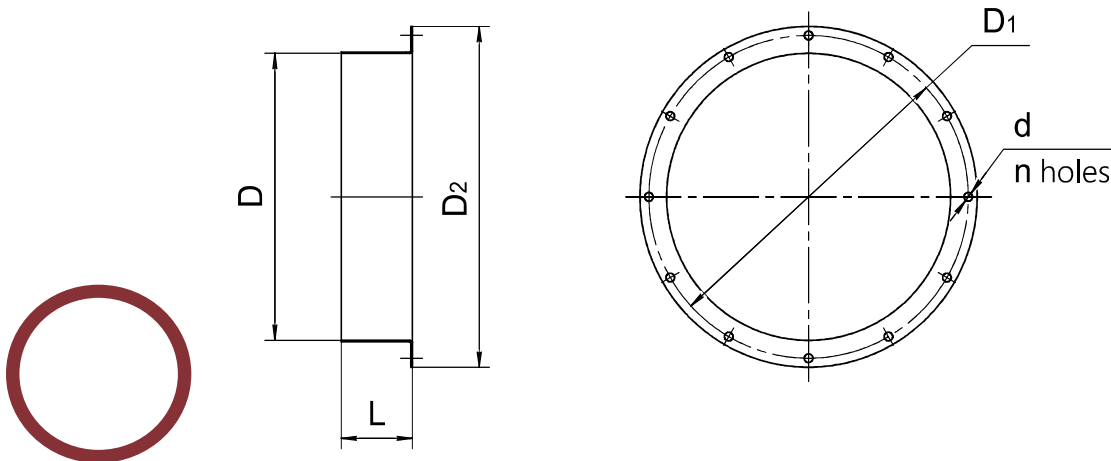

STANDARD SIZE	040	045	050	056	063	071	080	090	100	112	125
D, mm	400	450	500	560	630	710	800	900	1000	1120	1250
D1, mm	430	480	530	620	690	770	860	960	1070	1195	1320
D2, mm	460	510	560	660	730	810	900	1000	1110	1235	1360
L, mm	100	110	110	110	110	125	125	125	125	140	140
d, mm	12	12	12	12	12	12	12	14	14	14	14
n	8	8	12	12	12	16	16	16	16	20	20
Weight, kg	1,3	1,6	1,8	2,1	2,9	3,7	5,2	4,7	5,1	6,5	7,1

OZA-FOT-063-NS

- counter flange
- OZA fan size (•040 •045 •050 •056 •063 •071 •080 •090 •100 •112 •125)
- material (•NS - stainless steel •ZS - galvanized steel)





WEATHER PROTECTION HOOD

OZA-ZNT

for outdoor use of axial fans, the OZA-ZNT weather protection hood is provided.



•040 •045 •050 •056 •063 •071 •080 •090 •100 •112 •125

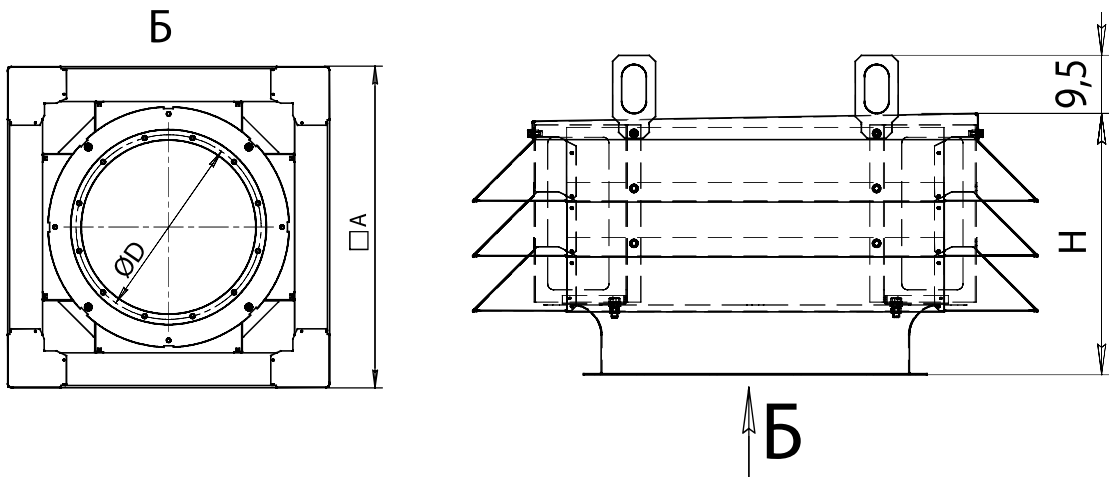

ENERGY EFFICIENT AXIAL FANS

STANDARD SIZE	040	045	050	056	063	071	080	090	100	112	125
A, mm	740	805	920	920	1030	1105	1201	1405	1560	1680	1680
H, mm	329	320	428	442	458	473	497	525	550	540	540
D, mm	430	480	530	620	690	770	860	960	1070	1195	1320
Weight, kg	15	17,5	28,1	31,5	34,2	37,4	48,3	55	68	80	82,5



OZA-ZNT-063-NS

- weather protection hood
- OZA fan size
(•040 •045 •050 •056 •063 •071 •080 •090 •100 •112 •125)
- material (•NS - stainless steel •ZS - galvanized steel)

90





OZA-VKO | INLET HEADER



the OZA-VKO inlet header is used to correctly form a uniform velocity diagram when the flow enters the blades of an axial fan impeller when operating without a network at the inlet. OZA-VKO must also be installed on the suction duct during subsequent installation of the fan, since with a flanged flow inlet into an axial fan or duct, there is a significant reduction in the flow rate and pressure generated by the fan due to losses at the flange edge;

one side of the OZA-VKO is attached to the inlet flange of the OZA series axial fan casing; to the other side can be attached, for example, the OZA-SEV (large protective mesh).

•040 •045 •050 •056 •063 •071 •080 •090 •100 •112 •125

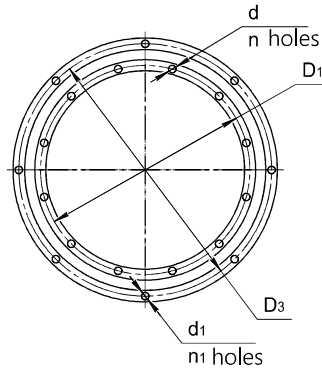
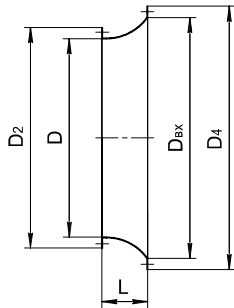
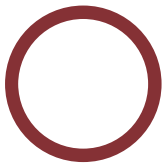

STANDARD SIZE	040	045	050	056	063	071	080	090	100	112	125
D, mm	400	450	500	560	630	710	800	900	1000	1120	1250
D1, mm	430	480	530	620	690	770	860	960	1070	1195	1320
D2, mm	460	510	560	660	730	810	900	1000	1110	1235	1360
D3, mm	540	585	650	720	805	910	1045	1145	1265	1410	1410
D4, mm	570	620	690	760	840	950	1090	1195	1315	1460	1460
Dbx, mm	485	546	606	680	764	861	970	1092	1213	1358	1358
L, mm	92	103	115	129	145	163	184	207	230	215	201
d, mm	12	12	12	12	12	12	12	14	14	14	14
n	8	8	12	12	12	16	16	16	16	20	20
d1, mm	12	12	12	12	12	12	11	11	11	11	11
n1	6	6	8	8	8	12	12	12	12	12	12
Weight, kg	3,4	3,5	3,5	5,9	7,7	9,9	13,1	14,5	21	27	28,3

OZA-VKO-063-NS

- inlet header
- OZA fan size (•040 •045 •050 •056 •063 •071 •080 •090 •100 •112 •125)
- material (•NS - stainless steel •ZS - galvanized steel)





FLEXIBLE CONNECTOR **OZA-COM**

- ▶ the OZA-COM flexible connector is designed to connect fans to air ducts or valves to prevent the transmission of vibration loads or resonant force effects of elements of air duct networks;
- ▶ the OZA-COM flexible connector consists of a special sleeve and metal flanges fixed in the sleeve through the rims with rivets. The flanges can be made of stainless or galvanized steel.
- ▶ DESIGN
 - OZA-COM-100 - general purpose industrial;
 - OZA-COM-120 - general purpose industrial, antistatic.

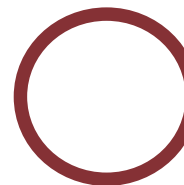
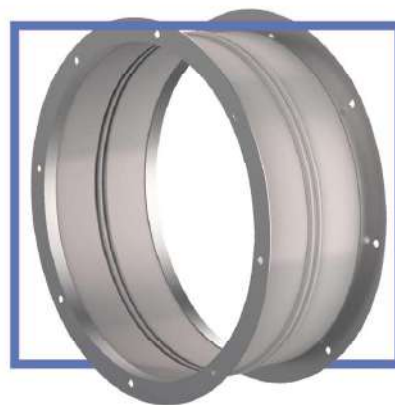

•040 •045 •050 •056 •063 •071 •080 •090 •100 •112 •125

SERIES	OPERATING CONDITIONS		
	HANDLED AIR MIXTURE	OPERATING PRESSURE, Pa	TEMPERATURE, °C
OZA-COM-100	non-aggressive	1500	від -40 до +70
OZA-COM-120	non-aggressive explosive (antistatic surface)	1500	від -40 до +70

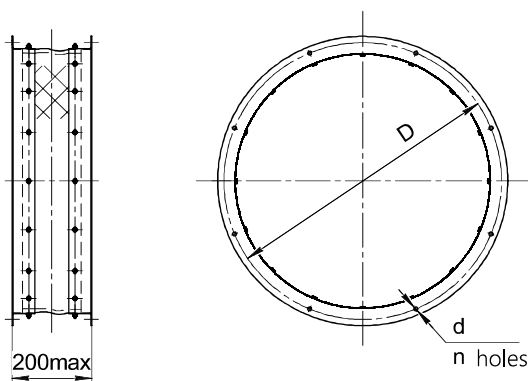

STANDARD SIZE	040	045	050	056	063	071	080	090	100	112	125
D, mm	430	480	530	620	690	770	860	960	1070	1195	1320
d, mm	12	12	12	12	12	12	12	14	14	14	14
n	8	8	12	12	12	16	16	16	16	20	20
Weight, kg	4,7	5,3	7,6	8,3	9,3	11,0	12,4	14,7	16,3	18,4	20,4

OZA-COM-100-063-NS

- ▶ flexible connector
- ▶ series (•100 •120)
- ▶ OZA fan size (•040 •045 •050 •056 •063 •071 •080 •090 •100 •112 •125)
- ▶ material (•NS - stainless steel •ZS - galvanized steel)



OZA-PEP | FLAT ADAPTER

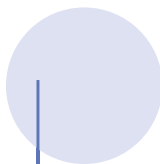
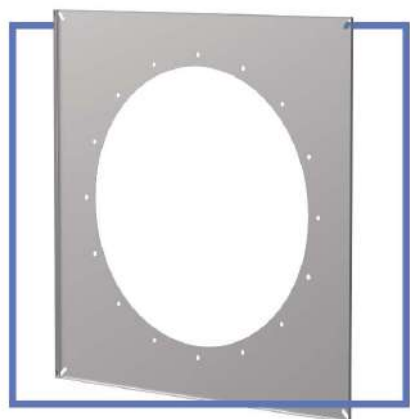

the OZA-PEP flat adapter is used as an adapter element for attaching a rectangular valve of the TUL, REG or GMK type to the output section of the axial fan OZA series.

•040 •045 •050 •056 •063 •071 •080 •090 •100 •112 •125

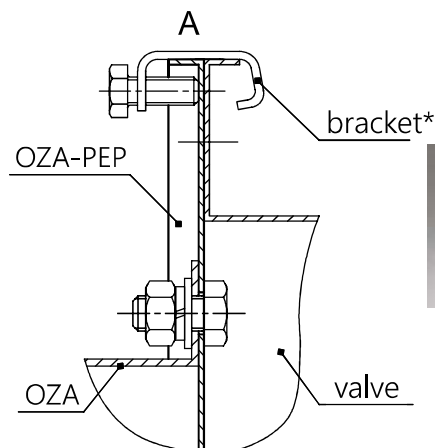
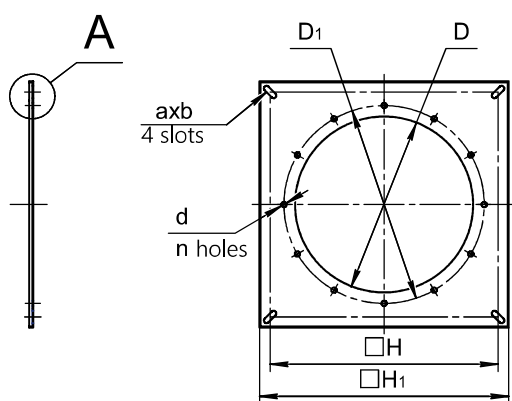

*it is allowed to install brackets

STANDARD SIZE	040	045	050	056	063	071	080	090	100	112	125
D, mm	400	450	500	560	630	710	800	900	1000	1120	1250
D1, mm	430	480	530	620	690	770	860	960	1070	1195	1320
H, mm		650		795		945	1085		1395	1545	
H1, mm		685		830		980	1130		1430	1580	
d, mm				12					14		
n	8	8	12	12	12	16	16	16	16	20	20
axb, mm			10x30					12x30			
Weight, kg	2,7	2,5	2,2	3,5	4,5	6,7	9,1	7,6	14,8	17,7	14,9

OZA-PEP-063-NS

- flat adapter
- OZA fan size
(•040 •045 •050 •056 •063 •071 •080 •090 •100 •112 •125)
- material (•NS - stainless steel •ZS - galvanized steel)





АДАПТЕР ТОРОЇДАЛЬНИЙ

OZA-PET

- the OZA-PET toroidal adapter is used to form a uniform velocity diagram when the flow enters the impeller blades. OZA-PET must necessarily be installed when the fan is operating in the discharge mode, since with a flanged flow inlet into the axial fan, there is a significant reduction in the flow rate and the pressure generated;
- one side of the OZA-PET adapter is attached to the inlet flange of the OZA series axial fan casing, and the other side is attached to a TUL, REG or GMK valve.



•040 •045 •050 •056 •063 •071 •080 •090 •100 •112 •125

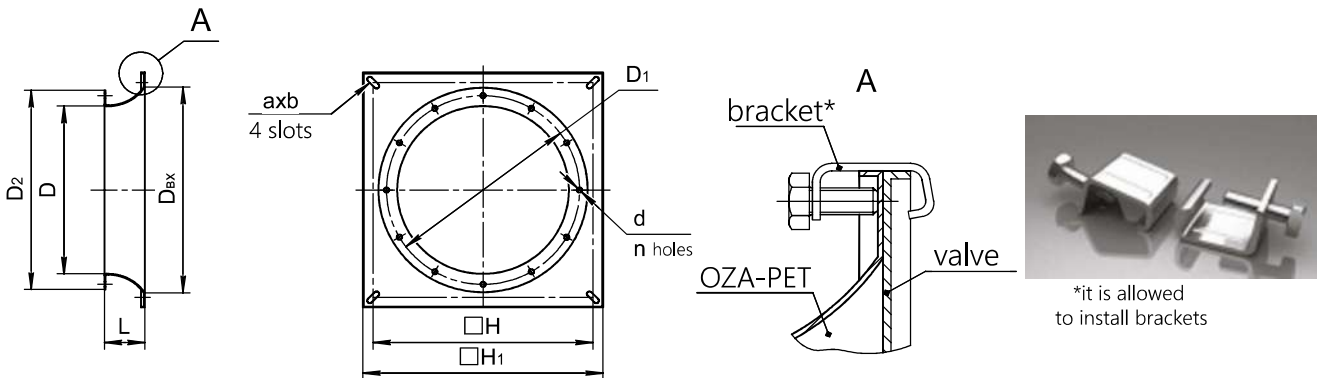

STANDARD SIZE	040	045	050	056	063	071	080	090	100	112	125	
D, mm	400	450	500	560	630	710	800	900	1000	1120	1250	
D1, mm	430	480	530	620	690	770	860	960	1070	1195	1320	
D2, mm	460	510	560	660	730	810	900	1000	1110	1235	1360	
Dax, mm	485	546	606	680	764	861	970	1092	1213	1358	1358	
L, mm	92	103	115	129	145	163	184	207	230	215	201	
H, mm	650			795			1085		1395		1545	
H1, mm	685		730	830	870	980	1130	1240	1430	1580		
d, mm						12			14			
n	8			12			16			20		
axb, mm	10x30					12x30						
Weight, kg	3,8	3,9	3,9	6,5	8,5	11,0	14,6	16,1	23,3	30,0	31,5	

ENERGY EFFICIENT AXIAL FANS

94

- toroidal adapter _____
- OZA fan size _____
(•040 •045 •050 •056 •063 •071 •080 •090 •100 •112 •125)
- material (•NS - stainless steel •ZS - galvanized steel) _____

OZA-PET-063-NS





OZA-PEK ROOF ADAPTER



- the OZA-PEK roof adapter is used to form a uniform velocity diagram when the flow enters the impeller blades;
- one side of the OZA-PEK adapter is attached to the inlet flange of the OZA fan casing, and the other side is attached to the STAM roof curb.

•040 •045 •050 •056 •063 •071 •080 •090 •100 •112 •125

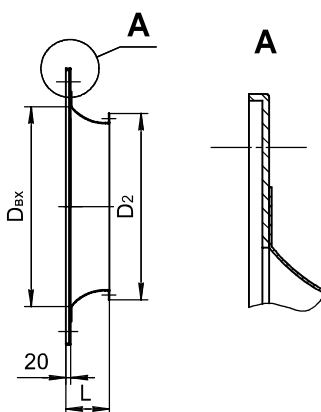
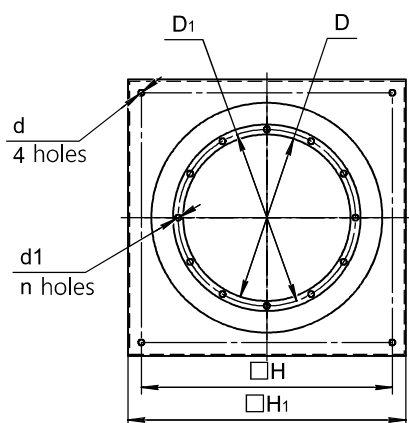

STANDARD SIZE OF COMBINED PRODUCTS

TYPE OF EQUIPMENT		
OZA	VKOP O	STAM
040	040	56
045	045	63
050	050	71
056	056	88
063	063	90
071	071	109
080	080	112
090	090	136
100	100	
112	112	
125	125	

STANDARD SIZE	040	045	050	056	063	071	080	090	100	112	125
D, mm	400	450	500	560	630	710	800	900	1000	1120	1250
D1, mm	430	480	530	620	690	770	860	960	1070	1195	1320
D2, mm	460	510	560	660	730	810	900	1000	1110	1235	1360
D _{ex} , mm	485	546	606	680	764	861	970	1092	1213	1358	1358
L, mm	110	121	133	147	163	181	202	225	248	233	219
H, mm	690	755	840	840	1005	1050	1220	1350	1505	1505	1505
H1, mm	740	805	890	890	1065	1105	1275	1405	1560	1560	1560
d, mm	14										18
d1, mm	12					14					
n	8			12			16			20	
Weight, kg	4,0	4,2	4,4	6,8	10,1	12,5	14,2	17,3	29,1	29,6	31,1

OZA-PEK-063-NS

- roof adapter _____
- OZA fan size _____
(•040 •045 •050 •056 •063 •071 •080 •090 •100 •112 •125)
- material (•NS - stainless steel •ZS - galvanized steel) _____





STRAIGHT SECTION OF THE DUCT

OZA-PUV

the straight section of the OZA-PUV air duct is used when installing axial fans in ventilation systems. Installation of a straight section is especially necessary in front of the fan if there are shaped elements in the inlet sections of the air ducts, as well as behind the outlet section of an axial fan without a guide apparatus.



•040 •045 •050 •056 •063 •071 •080 •090 •100 •112 •125

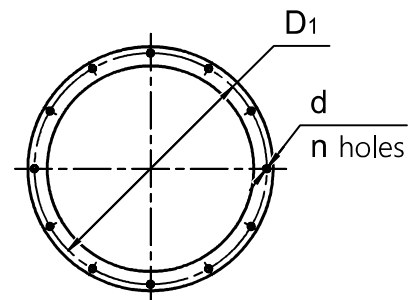
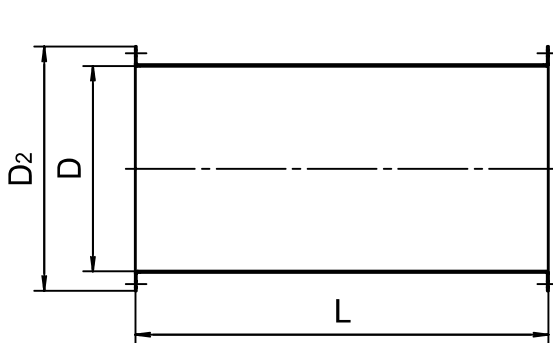

ENERGY EFFICIENT AXIAL FANS

STANDARD SIZE	040	045	050	056	063	071	080	090	100	112	125
D, mm	400	450	500	560	630	710	800	900	1000	1120	1250
D1, mm	430	480	530	620	690	770	860	960	1070	1195	1320
D2, mm	460	510	560	660	730	810	900	1000	1110	1235	1360
L, mm	800	900	1000	1120	1150	1150	1150	1150	1140	1135	1140
d, mm	12					14					
n	8	8	12	12	12	16	16	16	16	20	20
Weight, kg	8.5	11,0	13,2	17,7	27,7	31,2	35,1	39,4	43,5	49,0	54,0

OZA-PUV-063-NS

- straight section of the duct
- OZA fan size (•040 •045 •050 •056 •063 •071 •080 •090 •100 •112 •125)
- material (•NS - stainless steel •ZS - galvanized steel)





OZA-R50 | DECORATIVE GRILLE



- ▶ non-adjustable aluminum grilles of the OZA-R50 type are intended for external decoration of the outlets of ventilation shafts, air ducts, openings, and, if necessary, for decorating the facade of premises;
- ▶ the grilles can be equipped inside with a perforated metal mesh to prevent foreign objects from entering the protected area. The upper shelf of the OZA-R50 grille casing has a so-called "drip mold" to protect against precipitation entering the inner cavity of the grille.

•040 •045 •050 •056 •063 •071 •080 •090 •100 •112 •125

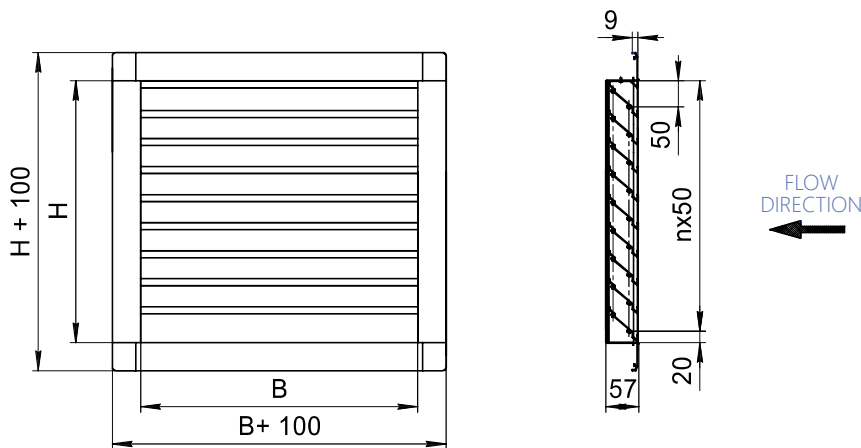

H, mm	B, mm														
	600	700	800	900	1000	1100	1200	1300	1400	1500	1600	1700	1800	1900	2000
520	-	0,218	0,250	0,281	0,312	0,343	0,374	0,406	0,437	0,468	0,499	0,530	0,562	0,593	0,624
620	-	0,260	0,298	0,335	0,372	0,409	0,446	0,484	0,521	0,558	0,595	0,632	0,670	0,707	0,744
720	-	0,302	0,346	0,389	0,432	0,475	0,518	0,562	0,605	0,648	0,691	0,734	0,778	0,821	0,864
820	-	0,344	0,394	0,443	0,492	0,541	0,590	0,640	0,689	0,738	0,787	0,836	0,886	0,935	0,984
920	-	0,386	0,442	0,497	0,552	0,607	0,662	0,718	0,773	0,828	0,883	0,938	0,994	1,049	1,104
1020	0,367	0,428	0,490	0,551	0,612	0,673	0,734	0,796	0,857	0,918	0,979	1,040	1,102	1,163	1,224
1120	0,403	0,470	0,538	0,605	0,672	0,739	0,806	0,874	0,941	1,008	1,075	1,142	1,210	1,277	1,344
1220	0,439	0,512	0,586	0,659	0,732	0,805	0,878	0,952	1,025	1,098	1,171	1,244	1,318	1,391	1,464
1320	0,475	0,554	0,634	0,713	0,792	0,871	0,950	1,030	1,109	1,188	1,267	1,346	1,426	1,505	1,584
1420	0,511	0,596	0,682	0,767	0,852	0,937	1,022	1,108	1,193	1,278	1,363	1,448	1,534	1,619	1,704
1520	0,547	0,638	0,730	0,821	0,912	1,003	1,094	1,186	1,277	1,368	1,459	1,550	1,642	1,733	1,824
1620	0,583	0,680	0,778	0,875	0,972	1,069	1,166	1,264	1,361	1,458	1,555	1,652	1,750	1,847	1,944
1720	0,619	0,722	0,826	0,929	1,032	1,135	1,238	1,342	1,445	1,548	1,651	1,754	1,858	1,961	2,064
1820	0,655	0,764	0,874	0,983	1,092	1,201	1,310	1,420	1,529	1,638	1,747	1,856	1,966	2,075	2,184
1920	0,691	0,806	0,922	1,037	1,152	1,267	1,382	1,498	1,613	1,728	1,843	1,958	2,074	2,189	2,304
2020	0,727	0,848	0,970	1,091	1,212	1,333	1,454	1,576	1,697	1,818	1,939	2,060	2,182	2,303	2,424
2120	0,763	0,890	1,018	1,145	1,272	1,399	1,526	1,654	1,781	1,908	2,035	2,162	2,290	2,417	2,544
2220	0,799	0,932	1,066	1,199	1,332	1,465	1,598	1,732	1,865	1,998	2,131	2,264	2,398	2,531	2,664
2320	0,835	0,974	1,114	1,253	1,392	1,531	1,670	1,810	1,949	2,088	2,227	2,366	2,506	2,645	2,784
2420	0,871	1,016	1,162	1,307	1,452	1,597	1,742	1,888	2,033	2,178	2,323	2,468	2,614	2,759	2,904
2520	0,907	1,058	1,210	1,361	1,512	1,663	1,814	1,966	2,117	2,268	2,419	2,570	2,722	2,873	3,024





When choosing OZA-R50 grilles, it is advisable to select the width (B) of the grille as a multiple of 10 mm, while its height (H) should be a multiple of 50 mm + 20 mm to the resulting value for "drip mold". The cross-section of the grille should not overlap the opening in the wall.

OZA-R50-820x800-C

- ▶ decorative grille
- ▶ useful cross section •HxB (H, mm - height; B, mm - width)
- ▶ availability of the mesh (•C – with mesh; •0 – without mesh)

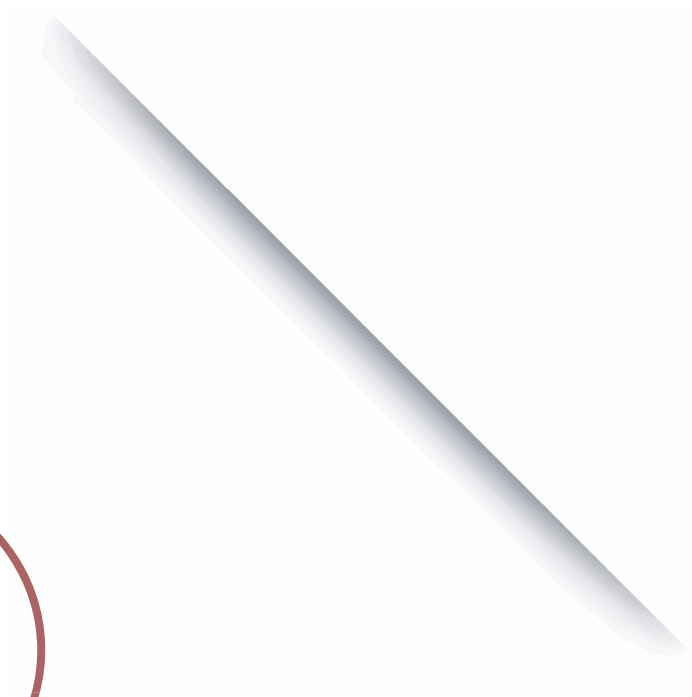

OZA-SEM, OZA-SEB | PROTECTIVE MESH

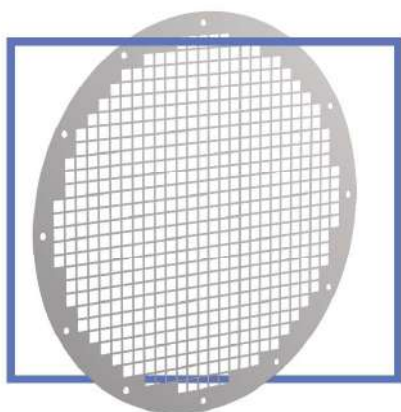

- the OZA-SEM, OZA-SEB protective mesh is used to prevent external mechanical impact and ingress of foreign objects larger than 50 mm into the OZA series axial fan;
- protection level IP1X;
- the OZA-SEM mesh (small) is installed at the outlet, and the OZA-SEB (large) mesh is installed at the free flow inlet to the fan;
- the protective mesh consists of a mounting flange and a welded or woven wire mesh.

•040 •045 •050 •056 •063 •071 •080 •090 •100 •112 •125

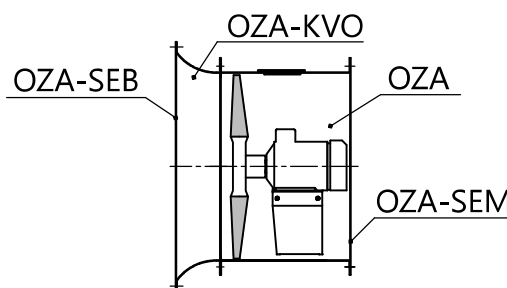
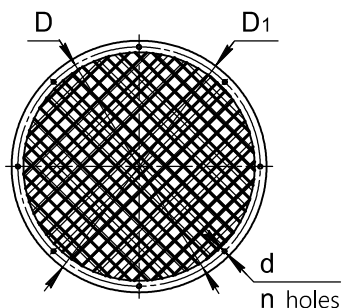

STANDARD SIZE	040	045	050	056	063	071	080	090	100	112	125
OZA-SEM											
D, mm	430	480	530	620	690	770	860	960	1070	1195	1320
D1, mm	460	510	560	660	730	810	900	1000	1110	1235	1360
d, mm	12	12	12	12	12	12	12	14	14	14	14
n	8	8	12	12	12	16	16	16	16	20	20
Weight, kg	0,5	0,6	0,8	1,1	2,0	2,4	3,0	3,7	4,5	4,7	6,8
OZA-SEB											
D, mm	540	585	650	720	805	910	1045	1145	1265	1410	1410
D1, mm	570	620	690	760	840	950	1090	1195	1315	1460	1460
d, mm	12	12	12	12	12	12	12	11	11	11	11
n	6	6	8	8	8	12	12	12	12	12	12
Weight, kg	0,8	1,0	1,2	1,4	2,6	3,3	4,4	5,3	6,4	7,9	7,9

OZA-SEM-063-NS

- protective mesh (•OZA-SEM •OZA-SEB)
- OZA fan size (•040 •045 •050 •056 •063 •071 •080 •090 •100 •112 •125)
- material (•NS - stainless steel •ZS - galvanized steel)

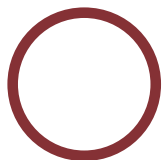

FREQUENCY CONVERTERS

ASC-150, ASC-310

- ▶ the ASC-150, ASC-310 series of frequency converters is universal for use in heating, ventilation and air conditioning systems with the possibility of integration into the upper level;
- ▶ energy savings;
- ▶ 98% EFFICIENCY, "Automatic Energy Optimization" function. The Automatic Energy Optimization (AEO) function built into the standard frequency converter ensures optimal motor magnetization at all speeds and loads. Thanks to this function, power consumption is reduced by 5-15% under partial load.
- ▶ POWER CONSUMPTION MONITORING. Ability to control power consumption using ASC-150, ASC-310 frequency converters for specified counting periods in hours, days or weeks.



TYPE	ASC-150	ASC-310
Operating voltage	3x380-480 V / 3x200-240 V	3x380-480 V/1x200-240 V
Mains frequency	45-66 Hz	45-66 Hz
Ingress protection rating	•IP20	•IP20 •IP21
Maximum motor cable length	30-60 m	30-60 m
Normal overload	(150%) within 1 min.и	within 1 min.

Model		Motor power, kW		Continuous output current, A		Weight, kg		Dimensions HxWxD, mm	
ASC-150	ASC-310	ASC-150	ASC-310	ASC-150	ASC-310	ASC-150	ASC-310	ASC-150	ASC-310
						IP20/IP21		IP20/IP21	
single-phase supply voltage, 200-240 V									
0,37	0,37	0,37	0,37	2,4	2,4	1,1	1,1	239x70x142	239x70x161
0,75	0,75	0,75	0,75	4,7	4,7	1,3	1,3		
1,1	1,1	1,1	1,1	6,7	6,7	1,3	1,3		
1,5	1,5	1,5	1,5	7,5	7,5	1,5	1,5	239x105x142	239x105x165
2,2	2,2	2,2	2,2	9,8	9,8	1,5	1,5		
three-phase supply voltage, 380-480 V									
0,37	0,37	0,37	0,37	1,2	1,3	1,1	1,1	239x70x142	239x70x161
0,55	0,55	0,55	0,55	1,9	2,1				
0,75	0,75	0,75	0,75	2,4	2,6	1,3	1,3	239x105x142	239x70x161
1,1	1,1	1,1	1,1	3,3	3,6				
1,5	1,5	1,5	1,5	4,1	4,5				
2,2	2,2	2,2	2,2	5,6	6,2				
3	3	3	3	7,3	8,0				
4	4	4	4	8,8	9,7	—	—	—	—
—	5,5	—	5,5	—	13,8				
—	7,5	—	7,5	—	17,2				
—	11	—	11	—	25,4				
—	15	—	15	—	34,1				
—	18,5	—	18,5	—	41,8	4,4	4,4	—	244x260x169
—	22	—	22	—	48,4				

Note: for motors over 37 kW, frequency converters are available on request

ENERGY EFFICIENT AXIAL FANS

100

frequency converter (•ASC-150 •ASC-310) model



ASC-310-7,5





SAU-PPV, SAU-SPV | FAN CONTROL CABINETS



- ▶ the SAU-PPV (SAU-SPV) fan control cabinet is implemented on the basis of a power disconnecter, contactor and thermal electrical relay;
- ▶ in the SAU-PPV (SAU-SPV) control cabinet, a special fire safety contact is connected, when triggered, the SAU-PPV (SAU-SPV) control cabinet blocks the operation of the fan motor. Fire safety connection is mandatory when controlling the fan;
- ▶ high protection level (IP54) allows the use of the SAU-PPV (SAU-SPV) fan control cabinet in industrial enterprises.

A contactor is a switching device that allows control of current in the main contact circuit by supplying control voltage to the coil (starter). The main purpose of the starter is remote starting of three-phase asynchronous motors by direct connection to the mains.

The thermal relay included protects the motors from overloads of unacceptable duration. In this case, the contactor is the same starter designed to control a 3 – phase motor. Thus, the SAU-PPV (SAU-SPV) control cabinet performs the function of a contactor and starter.

A contactor with a 380V control coil is a relevant solution for industrial enterprises and developers, since the use of a 380V coil allows avoiding additional costs during installation. The load in most cases is asynchronous 3-phase motors with a voltage of 380V. In case of using 220V coils, it is necessary to use a fourth neutral conductor and install it in the contactor control circuit, which accordingly results in additional financial costs and labor hours loss.

The control circuit and the versatility of serial production make it possible to avoid errors when connecting on site and reduce installation time, which is limited only by connecting to the mains. The SAU-PPV (SAU-SPV) fan control cabinet operates in a wide temperature range from -40° C to + 55° C, with a service life of at least 10 years. Careful design development allowed for getting a number of additional advantages and convenience during installation and operation. To increase safety, a metal casing is used, which is coated with high-quality powder paint, which provides protection against corrosion. In addition, the grounded casing provides shielding of electromagnetic fields that occur when switching high currents. This ensures the protection of equipment and the safety of personnel. Additionally, a built-in load disconnecter is provided, which allows increasing the safety of this equipment during motor maintenance.

WARNING!

The main difference between SAU-PPV and SAU-SPV is the presence of a power service voltage disconnector.

In order to increase the safety of operation and maintenance of the fan, it is recommended to use a cabinet with a SAU-PPV service switch.

For more information about the type of service switch, see the "Duct equipment" catalog.

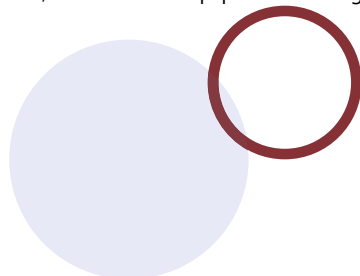

SAU-PPV-(7,0-10,0)

- ▶ fan control cabinet
- ▶ control type (•PPV - control cabinet with integrated voltage disconnector
•SPV - control cabinet without integrated voltage disconnector)
- ▶ range





The main distinguishing feature of the SAU-PPV (SAU-SPV) control cabinet is precise adjustment to the requirements of a specific network. It is known that regulatory documents and the Electrical Installation Code do not recommend using standard circuit breakers and fuses to protect motors, since they have only one setpoint and it is impossible to adjust them to a specific motor load. In contrast, the settings of thermal relays can be changed up to 50%.

Configuration algorithm. When connecting the load, it is necessary to set the relay setpoint to the maximum value first.

Then this value changes downwards until the relay is triggered. Thus, the exact value of the relay response threshold is determined. After that, the value is changed for the third time - just above the trigger threshold. For more precise threshold adjustment, this procedure can be repeated several times.

Fine adjustment is very important for low-power loads, namely for ventilation system motors. Correct relay settings will protect the motor from overloads that can be caused by aging of components, deterioration of insulation resistance, and drying out of grease in the bearings.

Restart. When the protection is triggered, the fan will not start using the "Start" button. In order to restart the fan, it is necessary to open the SAU-PPV (SAU-SPV) control cabinet, press the button to force return to the operating state of the thermal relay "R", close the SAU-PPV (SAU-SPV) control cabinet and then start the fan by pressing the "Start" button.

RANGE OF POSSIBLE SETTINGS OF THERMAL ELECTRICAL RELAYS

RELAY TYPE	ADJUSTMENT RANGE, A	RELAY TYPE	ADJUSTMENT RANGE, A
PTЛ 1001(M)	0,10-0,17	PTЛ 1008(M)	2,40-4,00
PTЛ 1002(M)	0,16-0,26	PTЛ 1010(M)	3,80-6,00
PTЛ 1003(M)	0,24-0,40	PTЛ 1012(M)	5,50-8,00
PTЛ 1004(M)	0,38-0,65	PTЛ 1014(M)	7,00-10,00
PTЛ 1005(M)	0,61-1,00	PTЛ 1016(M)	9,50-14,00
PTЛ 1006(M)	0,95-1,60	PTЛ-1021(M)	13,00-19,00
PTЛ 1007(M)	1,50-2,60		

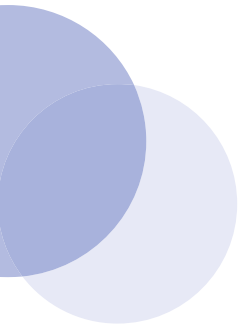

FOR NOTES

