



TABLE OF CONTENTS

COMPACT AIR HANDLING UNITS AEROSTART-EC-CF	3
Design	4
Model designation	4
Performance range	4
Example of using the aerodynamic characteristics and temperature efficiency graph of an integrated recuperative heat exchange	5
Standard series	6
Ceiling-suspended air handling units	6
Floor-mounted narrow profile air handling units	24
Floor-mounted air handling units	32
Automatic control system	48
CEILING-SUSPENDED AIR HANDLING UNITS WITH HEAT PUMP AEROSTART-EC-DX	51
Design	52
Model designation	52
Standard series	53
Automatic control system	61
AIR HANDLING UNITS AEROSMART-EC	63
Performance range	64
Model designation	64
Design	65
Design version	66
Example of using an aerodynamic characteristic	67
Standard series	68
Automatic control system	90
ADDITIONAL EQUIPMENT FOR AEROSTART-EC	
Universal duct air valve C-KVK	92
Insulated duct air valve C-GMK-C	93
Check valve for round ducts C-KOL-K	94
Single leaf damper C-DKK	94
Silencer for round ducts C-GKK	95
Filter for round ducts C-FKK	96
Bag filter for round ducts C-FKK-BAG	97
Compact filter for round ducts C-FKK-L	98
Electric air heater for round ducts C-EVN-K-S3	99
Electric air heater for rectangular ducts C-EVN-S3	101
Water/air-heater C-KVN-K	103
Water/air-heater C-KVN	103
Water/air-cooler C-VKO	104
Freon/air-cooler C-FKO	104

Rectangular adapter AD-PSKK	104
Supply and exhaust grille C-RPVC	106
Exhaust grille C-RVC	107
Air intake grille C-RVK	108
Non-adjustable grille RKN	109
Mounting clamp C-MK	110
Water mixing unit UWS	111

ADDITIONAL EQUIPMENT FOR AEROSMART-EC

Liquid air heater SMART-WH	115
Electric air heater SMART-EH	117
Liquid air cooler SMART-CW	120
Freon air cooler SMART-CF	122
Plate-type silencer SMART-S	124
Air filter SMART-F	126
Air valve SMART-HD	128
Insulated air valve SMART-ND	129

ADDITIONAL SENSORS

Duct air quality sensors AST-AQDM	131
Indoor air quality sensors AST-AQRM	131
CO ₂ sensor AST-CO2DM	131
Indoor CO ₂ sensor AST-CO2RM	131
Humidity sensor AST-RHDM	132
Indoor humidity sensor AST-RHRM	132
Hygrostat AST-RHDM-SW	132
Indoor hygrostat AST-RHDM-SW	132
CO ₂ detector-relay AST-CO2DM-SW	133
Indoor CO ₂ detector-relay AST-CO2RM-SW	133
Motion sensor AST-MSRM	133
Pressure-difference transducer AST-AFDM	134

AEROSTART-EC-CF

COMPACT AIR HANDLING UNIT

The AEROSTART-EC-CF compact air handling unit is designed for the organization of efficient mechanical supply and exhaust ventilation of various types of premises, ranging from residential premises to commercial construction objects, such as restaurants, shops, office premises, etc. The compact design of air handling units of suspended and floor (wall) design versions allows them to be conveniently placed in confined conditions.

BENEFITS:

- ✔ heat savings in the air handling units are achieved through the use of a highly efficient plate counter-flow recuperative heat exchanger with an efficiency of up to 95%. In air handling units of standard sizes 2000 and 3000, plate cross-flow recuperative heat exchangers with an efficiency of up to 70 are used;
- ✔ insulated housing of AEROSTART-EC-CF units effectively prevents heat loss, as well as the spread of noise generated by the running fans. The case is covered outside with protective and decorative powder paint, which eliminates the risk of corrosion;
- ✔ low noise is achieved through the use of an effective combination of low-noise fans and a noise-insulated casing;
- ✔ compact fans with EC motors significantly simplify the smooth control of air flow, which is very useful in terms of turning on ventilation as needed;
- ✔ automation system is fully placed inside the AEROSTART unit casing. In 900, 1300, 2000 and 3000 ceiling-suspended air handling units, the control board is located in the control cabinet, which is hung on the side wall of the air handling unit. There is no need to look for a place to install an external control cabinet. All air handling units are equipped with a remote control panel;
- ✔ convenient and easy installation. AEROSTART air handling units are designed according to the plug & play principle - only minimal actions are required for installation, connection and commissioning of the equipment





DESIGN

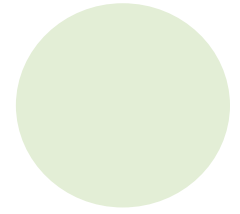

The casing of the AEROSTART-EC-CF units is made of galvanized steel with a protective and decorative powder paint coating, color RAL9016. Inside the casing, there are fans with electronically commutated (EC) motors that provide supply and exhaust of the air.

The air handling unit also includes compact air filters of M5 filtration class for both supply and exhaust air. A plate counter-flow air-to-air heat exchanger of the recuperative type is used as a recuperative heat exchanger. After the heat exchanger, a condensate collection pan is installed on the exhaust air side of the unit. The condensate drain pipe is located outside the unit casing.

An electric heater is installed inside the AEROSTART-EC-CF air handling unit casing (250, 500, 900 and 1300 standard sizes) to heat the air to the set temperature. Overheating protection of electric tubular heating elements is carried out by means of built-in protective thermostats.

Also, all actuators and automation devices located inside the AEROSTART-EC-CF unit casing are already connected to the built-in automation unit.

An electric optional heater is usually used as an air preheater that is installed upstream the recuperative heat exchanger.

AEROSTART-EC-CF-250-E-V-R

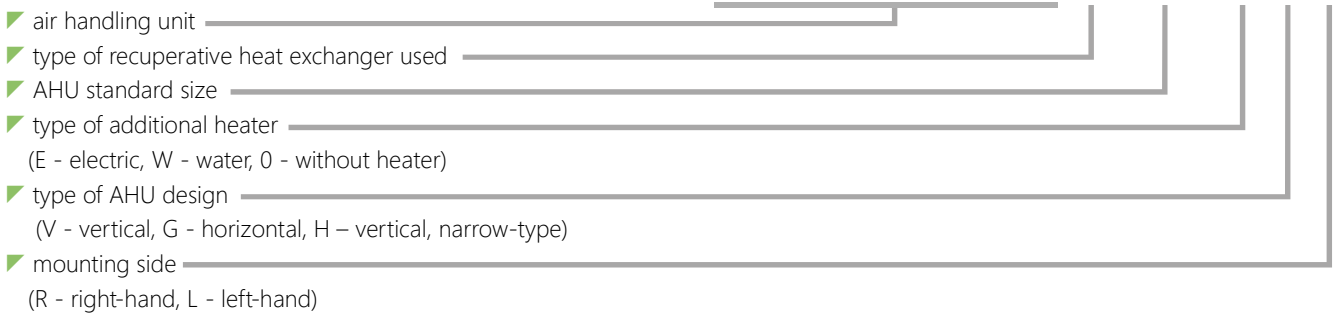

PERFORMANCE RANGE

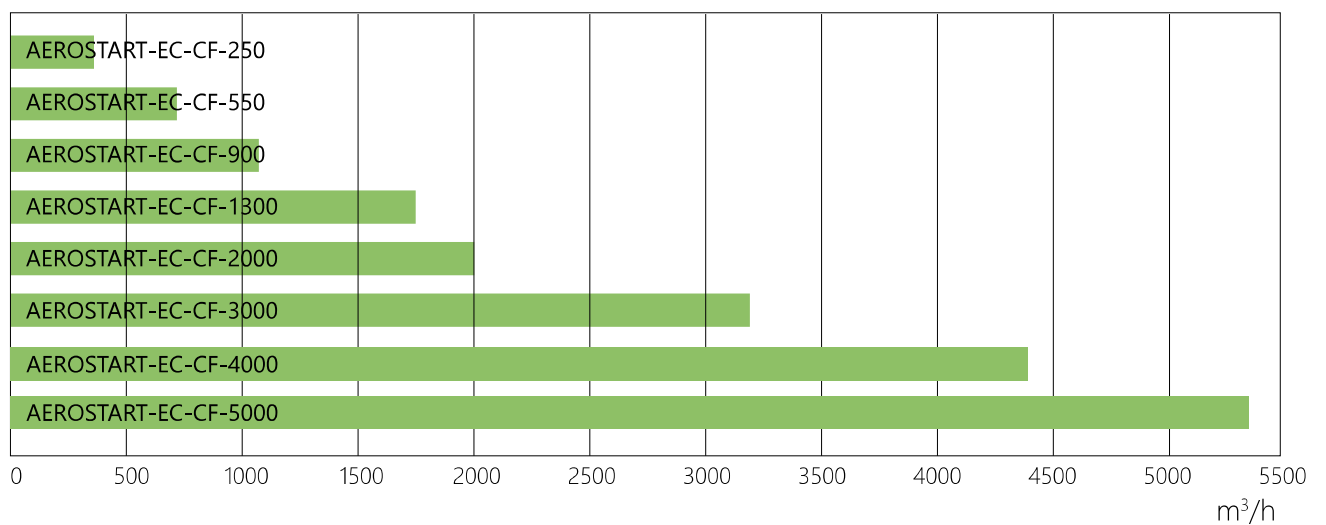

AIR HANDLING UNITS





EXAMPLE OF USING THE AERODYNAMIC CHARACTERISTIC AND TEMPERATURE EFFICIENCY GRAPH OF AN INTEGRATED RECUPERATIVE HEAT EXCHANGER

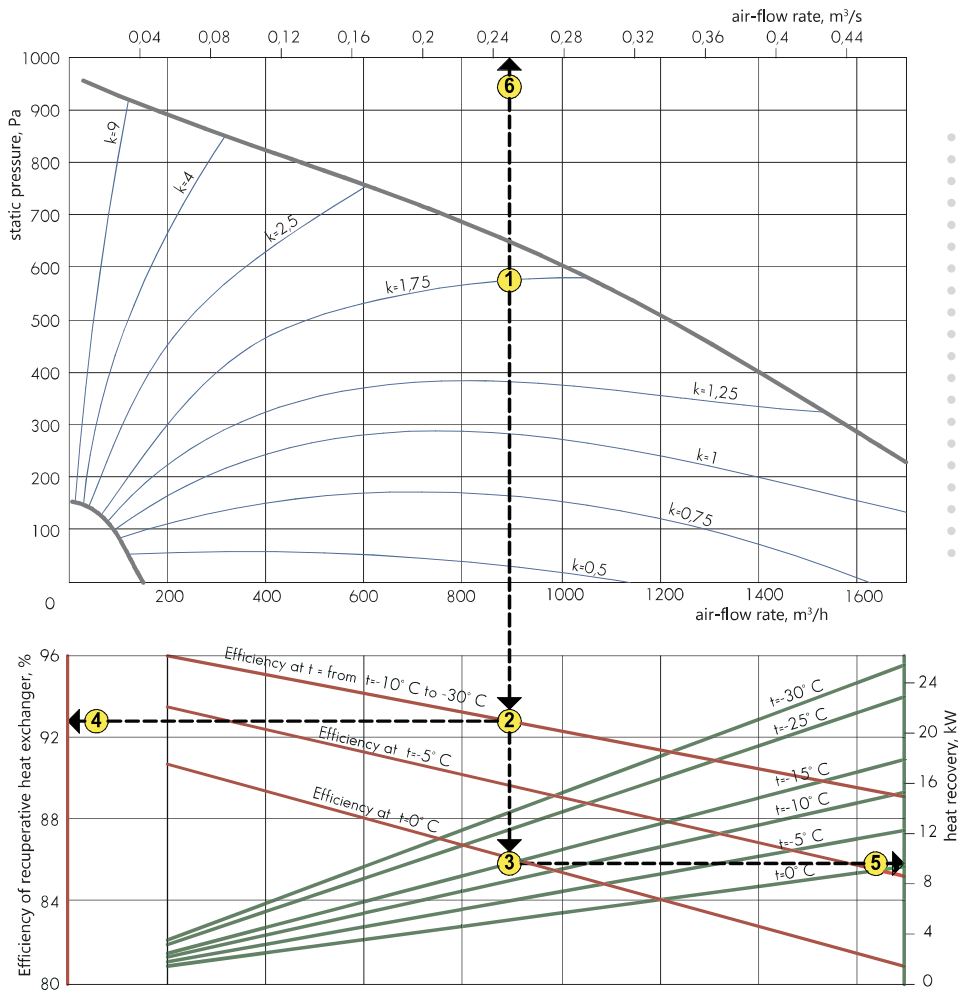

By selecting the required operating point on the aerodynamic diagram, we can determine the following:

- fan power consumption;
- efficiency of the recuperative heat exchanger for any flow rate within the operating range of the AHU, taking into account the parameters of outdoor air;
- total heat output of the recuperative heat exchanger.

EXAMPLE:

The AEROSTART-EC-CF-1300-G unit operates with an intake air flow rate of 900 m³/h at static pressure of 570 Pa, which corresponds to point 1.

In this case, we see that the closest curve to point 1 characterizing the fan power is the curve $k = 1.75$.

Following from point 1 vertically upwards to point 6, we obtain a volumetric flow rate of 0.25 m³/s.

Then, knowing the volumetric flow rate of the supply fan, we can calculate the power consumed by it using the formula:

$$N \text{ [kW]} = k \text{ [kW/(m}^3\text{/s)]} \times L \text{ [m}^3\text{/s]} = 1.75 \times 0.25 = 0.4375 \text{ kW}$$

Further, going down from point 1 to the graph of the temperature efficiency of the built-in recuperative heat exchanger, we can determine both the efficiency and its total heat output.

For an outdoor air temperature of $t = -15^\circ \text{C}$, the efficiency of the recuperative heat exchanger will be about 93% (points 2-4), and the total heat output will be about 9 kW (points 3-5). With a known recuperative heat exchanger capacity and supply air flow rate, it is easy to calculate the required heating power to a temperature of, for example, $+20^\circ \text{C}$:

- required power to heat 900 m³/g of air from outdoor temperature $t_1 = -15^\circ \text{C}$ to temperature $t_2 = +20^\circ \text{C}$:

$$Q = (L \times \rho \times c_{pe} \times (t_2 - t_1)) / 3600 = 900 \times 1.205 \times 1.005 \times (20 - (-15)) / 3600 = 10.6 \text{ kW}$$

- the required power for heating to temperature $t_2 = +20^\circ \text{C}$ is equal to the difference between the total required power calculated above and the total power of the recuperative heat exchanger

$$Q_{\text{heat}} = 10.6 - 9 = 1.6 \text{ kW}$$



AEROSTART-EC-CF-250-G

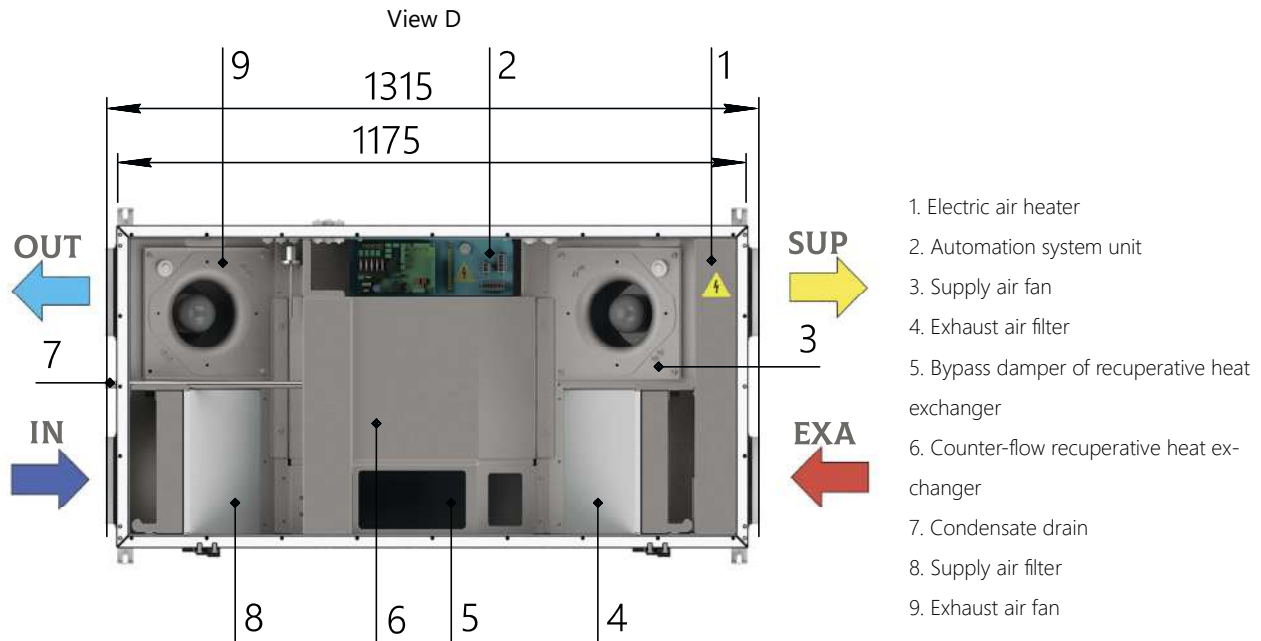

RIGHT-HAND VERSION

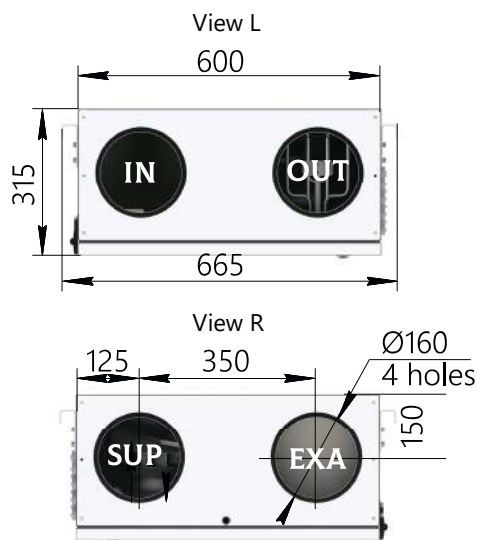

LEFT-HAND VERSION

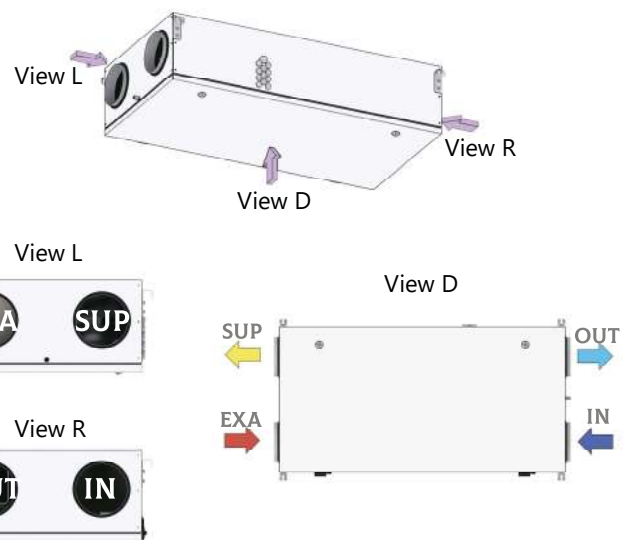

IN - outdoor air SUP - supply air EXA - exhaust air OUT - return air

AIR HANDLING UNITS

Parameter	VALUE
Nominal air-flow rate*, m ³ /h	250
External static pressure*, Pa	278
Maximum air flow rate (at static pressure 100 Pa), m ³ /h	340
Supply voltage	~1/220 V/50 Hz
Electric power of built-in electric heater, kW	0,9
Fan power (supply/exhaust), kW	0,08/0,08
Total electrical power of the AHU, kW	1,07
Filter (supply/exhaust)	M5/M5
Weight, kg, max	58

* The values are valid under normal conditions for both the supply and exhaust paths.

AEROSTART-EC-CF-250	Sound power level, dB								Total sound pressure level, dB(A)**
	Octave band mid-frequency, Hz*								
	63	125	250	500	1000	2000	4000	8000	
Input	49	48	48	50	43	38	32	26	49
Output	55	58	63	62	58	56	51	48	64
Surrounding	53	53	45	37	38	41	39	37	47

* At nominal flow rate and maximum fan speed.

** Total sound pressure level (not to be confused with power) at a distance of 3 meters.

AERODYNAMIC CHARACTERISTICS

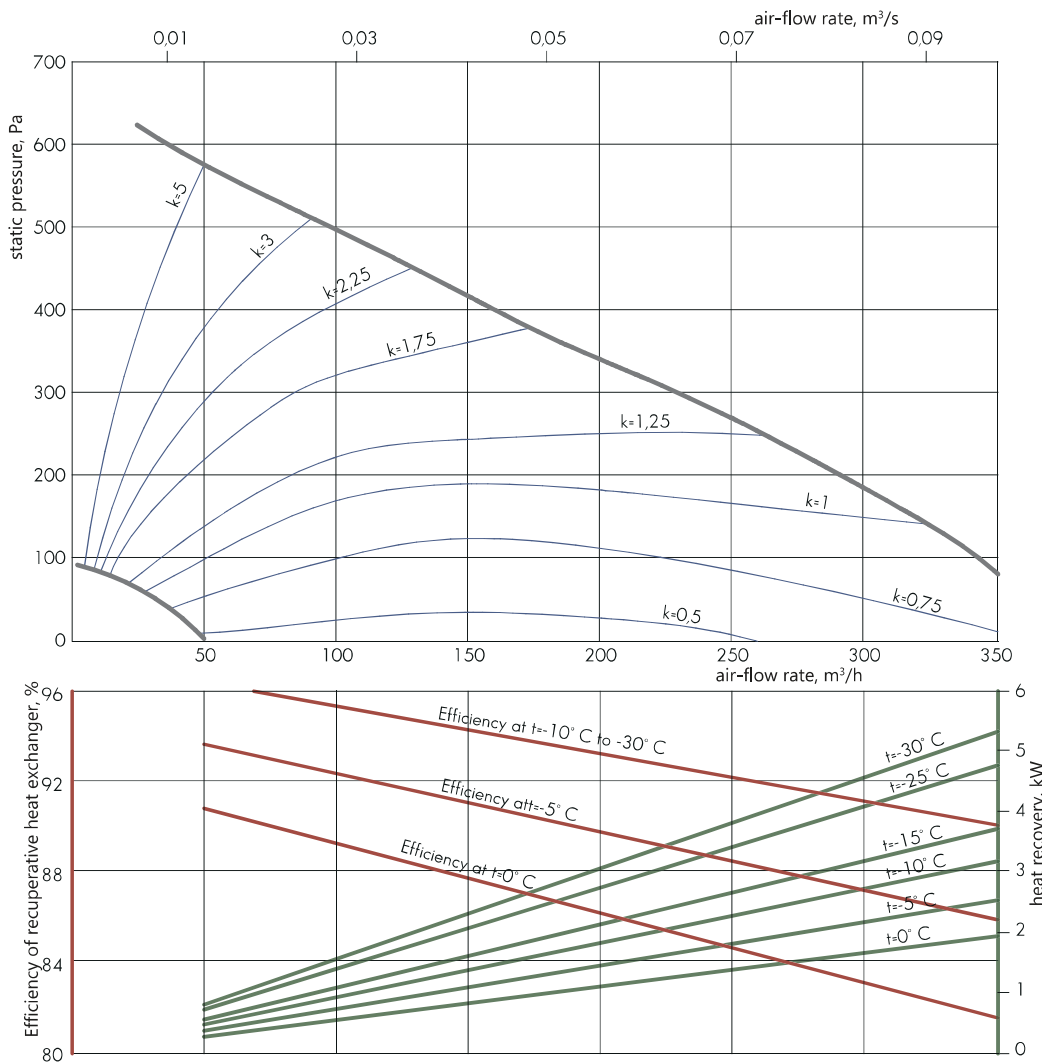

An example of using the aerodynamic characteristic and temperature efficiency graph is given above

TEMPERATURE EFFICIENCY

The temperature efficiency graph is shown at the same supply and exhaust air flow rates, and at the exhaust air temperature $t = +20^\circ\text{C}$, relative humidity $rh = 50\%$



- air valve
C-KVK-160
- insulated valve
C-GMK-C-40-20
- check valve
C-KOL-K-160
- single leaf damper
C-DKK-160
- duct silencer
C-GKK-160
- duct filter
C-FKK-160
- bag filter
C-FKK-160-BAG
- compact duct filter
C-FKK-L-160
- water/air-heater
C-KVN-K-160
- electric air heater
C-EVN-K-S3-160
- electric air heater
C-EVN-S3-40-20
- water/air-cooler
C-VKO-40-20
- Freon air cooler
C-FKO-40-20
- mounting clamp
C-MK-160
- adapter
AD-PSKK-400x200-160
- air intake grille
C-RVK-160
- exhaust grille
C-RVC-160
- supply and exhaust grille
C-RPVC-160
- non-adjustable grille
RKN-160
- water mixing unit
UWS

AIR HANDLING UNITS

AEROSTART-EC-CF-250-G-LITE

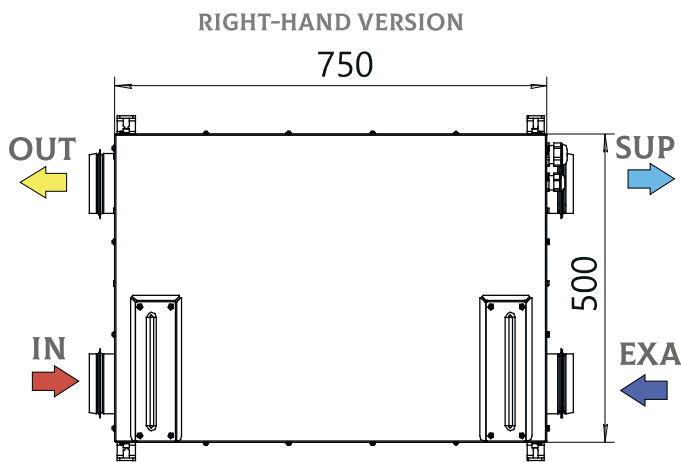
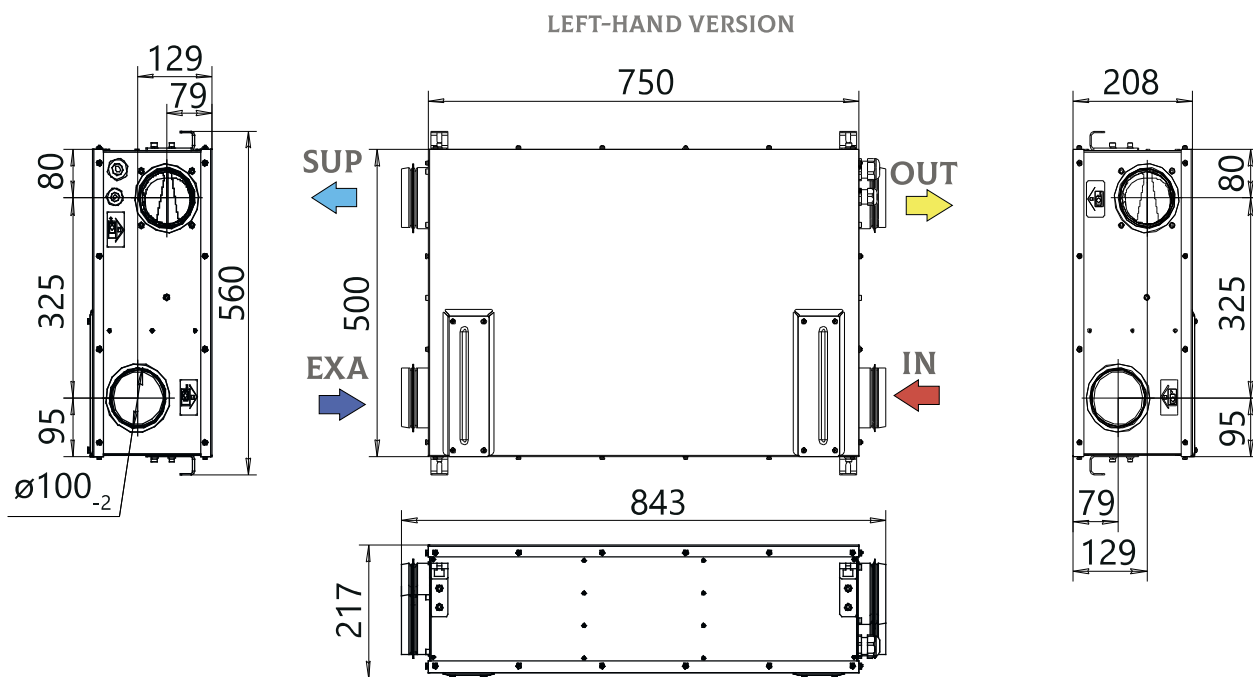

IN - outdoor air SUP - supply air EXA - exhaust air OUT - return air

AIR HANDLING UNITS

Parameter	VALUE
Nominal air-flow rate*, m ³ /h	250
Supply voltage	~1 / 220 V / 50 Hz
Maximum air flow rate (at static pressure 100 Pa), m ³ /h	230
Fan power (supply/exhaust), kW	0,085/0,085
Total electrical power of the AHU, kW	0,17
Filter (supply/exhaust)	G4/ G4
Weight, kg, max	20

* The values are valid in the absence of an air duct.

AEROSTART-EC-CF-250	Sound power level, dB								Total sound pressure level, dB(A)**
	Octave band mid-frequency, Hz*								
	63	125	250	500	1000	2000	4000	8000	
Input	35	44	44	53	49	47	47	44	55
Output	40	49	49	58	54	52	52	49	60
Surrounding	41	47	34	36	37	40	43	41	48

* At nominal flow rate and maximum fan speed.

** Total sound pressure level (not to be confused with power) at a distance of 3 meters.

AERODYNAMIC CHARACTERISTICS

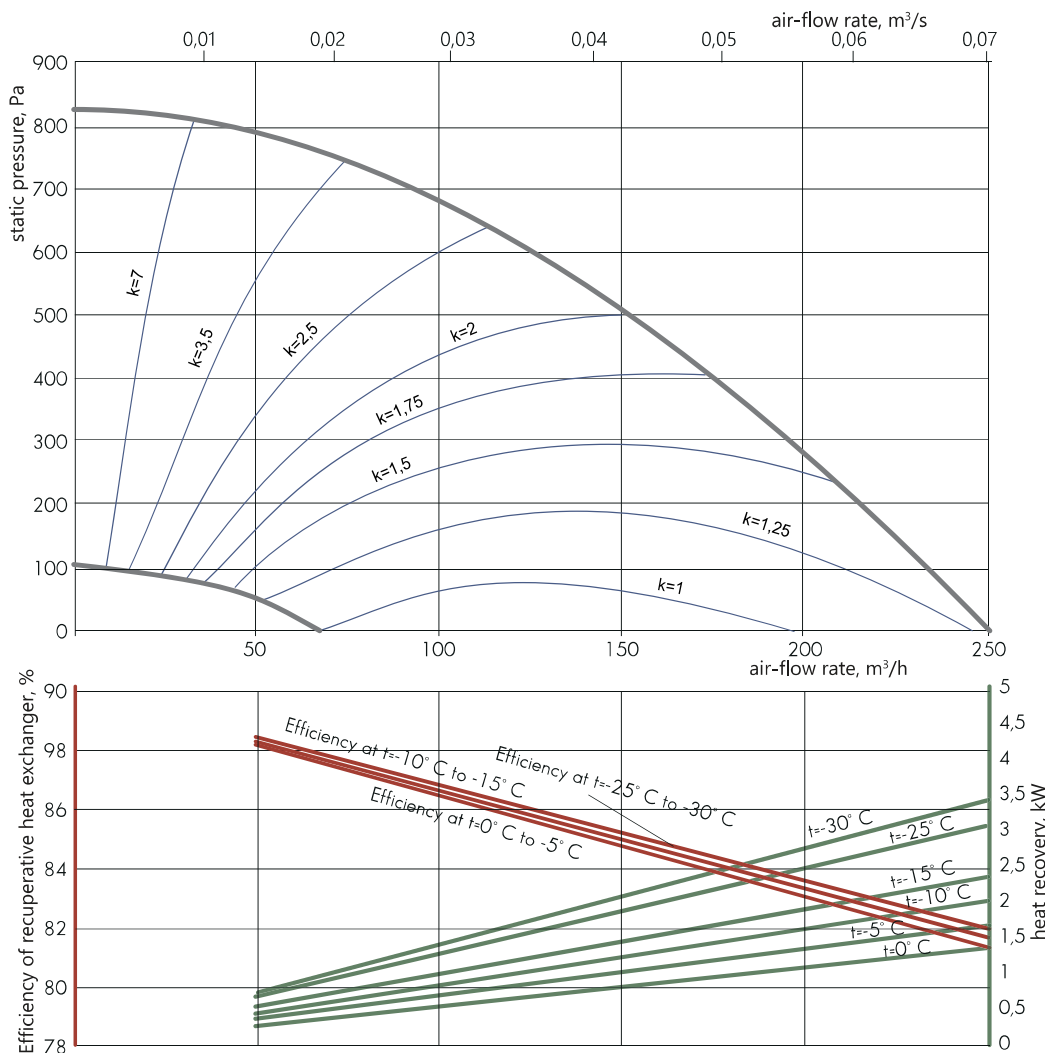

An example of using the aerodynamic characteristic and temperature efficiency graph is given above

TEMPERATURE EFFICIENCY

The temperature efficiency graph is shown at the same supply and exhaust air flow rates, and at the exhaust air temperature $t = +20^\circ\text{C}$, relative humidity $rh = 50\%$

- air valve
C-KVK-100
- check valve
C-KOL-K-100
- single leaf damper
C-DKK-100
- duct silencer
C-GKK-100
- duct filter
C-FKK-100
- bag filter
C-FKK-100-BAG
- compact duct filter
C-FKK-L-100
- electric air heater
C-EVN-K-S3-100
- electric air heater
C-EVN-S3-40-20
- mounting clamp
C-MK-100
- air intake grille
C-RVK-100
- exhaust grille
C-RVC-100
- supply and exhaust grille
C-RPVC-100
- non-adjustable grille
RKN-100



AEROSTART-EC-CF-550-G

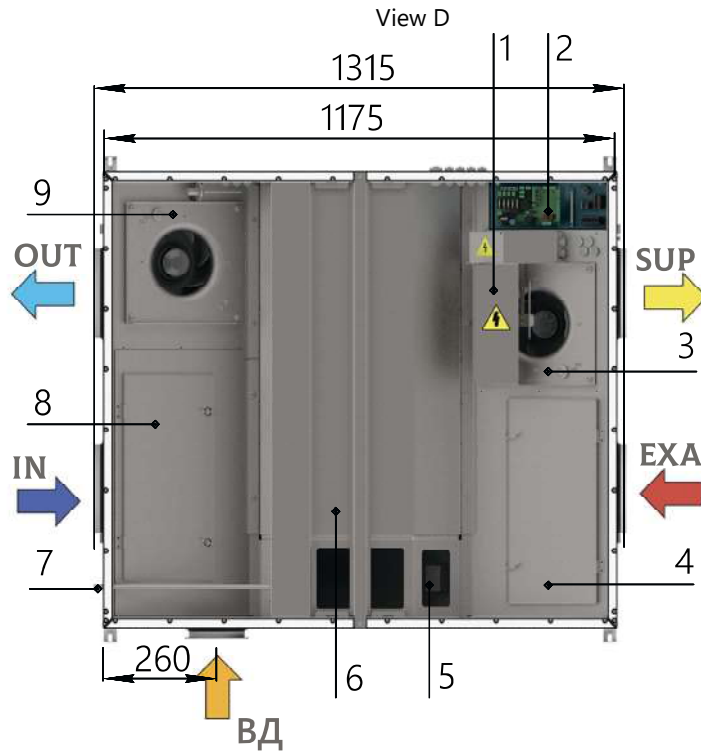

1. Electric air heater
2. Automation system unit
3. Supply air fan
4. Exhaust air filter
5. Bypass damper of recuperative heat exchanger
6. Counter-flow recuperative heat exchanger
7. Condensate drain
8. Supply air filter
9. Exhaust air fan

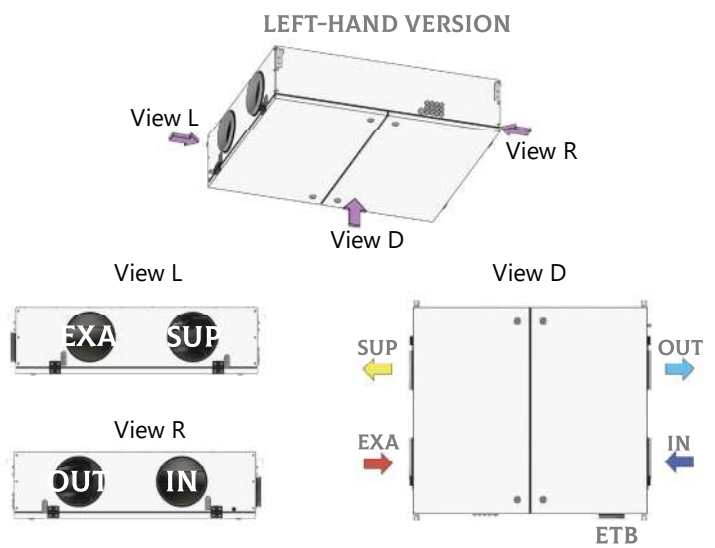
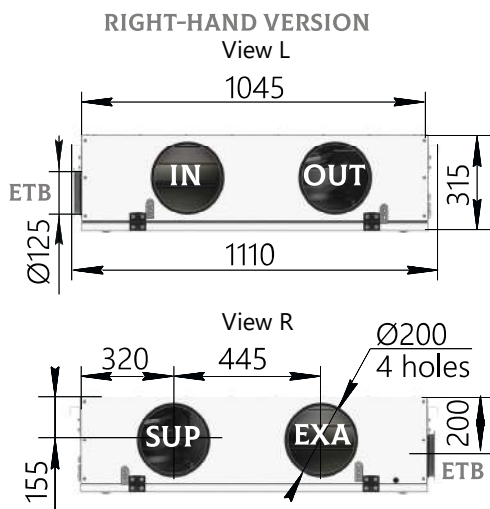

IN - outdoor air SUP - supply air EXA - exhaust air OUT - return air ETB - additional exhaust fan

Parameter	VALUE
Nominal air-flow rate*, m ³ /h	550
External static pressure*, Pa	240
Maximum air flow rate (at static pressure 100 Pa), m ³ /h	700
Supply voltage	~1 / 220 V / 50 Hz
Electric power of built-in electric heater, kW	2,0
Fan power (supply/exhaust), kW	0,17/0,17
Total electrical power of the AHU, kW	2,34
Filter (supply/exhaust)	M5/M5
Weight, kg, max	93

* The values are valid under normal conditions for both the supply and exhaust paths.

AEROSTART-EC-CF-550	Sound power level, dB								Total sound pressure level, dB(A)**
	Octave band mid-frequency, Hz*								
	63	125	250	500	1000	2000	4000	8000	
Input	43	42	41	46	44	41	37	32	48
Output	49	52	56	58	59	59	56	54	65
Surrounding	47	47	38	33	39	44	44	43	50

* At nominal flow rate and maximum fan speed.

** Total sound pressure level (not to be confused with power) at a distance of 3 meters.

AERODYNAMIC CHARACTERISTICS

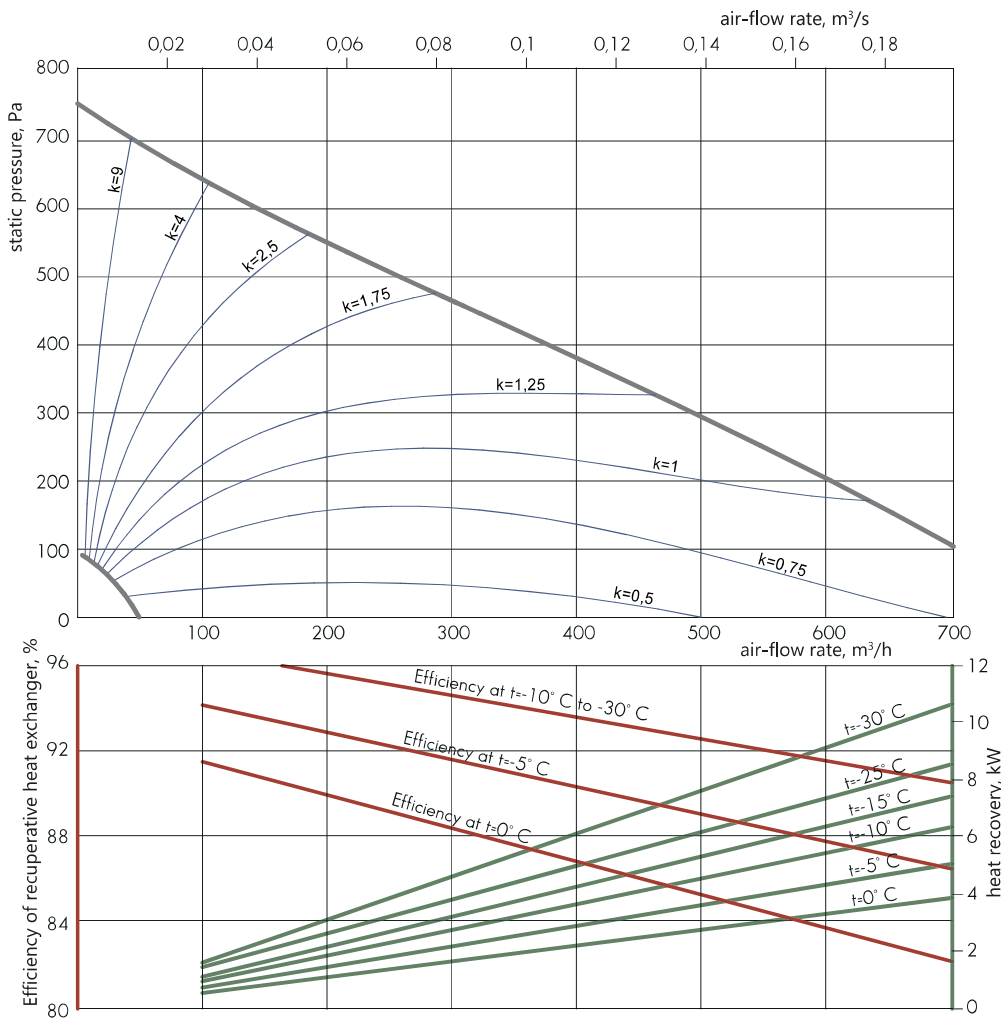

An example of using the aerodynamic characteristic and temperature efficiency graph is given above

TEMPERATURE EFFICIENCY

The temperature efficiency graph is shown at the same supply and exhaust air flow rates, and at the exhaust air temperature $t = +20^\circ\text{C}$, relative humidity $rh = 50\%$

- air valve
C-KVK-200
- insulated valve
C-GMK-C-40-20
- check valve
C-KOL-K-200
- single leaf damper
C-DKK-200
- duct silencer
C-GKK-200
- duct filter
C-FKK-200
- bag filter
C-FKK-200-BAG
- compact duct filter
C-FKK-L-200
- water/air-heater
C-KVN-K-200
- electric air heater
C-EVN-K-S3-200
- electric air heater
C-EVN-S3-40-20
- water/air-cooler
C-VKO-40-20
- Freon air cooler
C-FKO-40-20
- mounting clamp
C-MK-200
- adapter
AD-PSKK-400x200-200
- air intake grille
C-RVK-200
- exhaust grille
C-RVC-200
- supply and exhaust grille
C-RPVC-200
- non-adjustable grille
RKN-200
- water mixing unit
UWS

AEROSTART-EC-CF-900-G

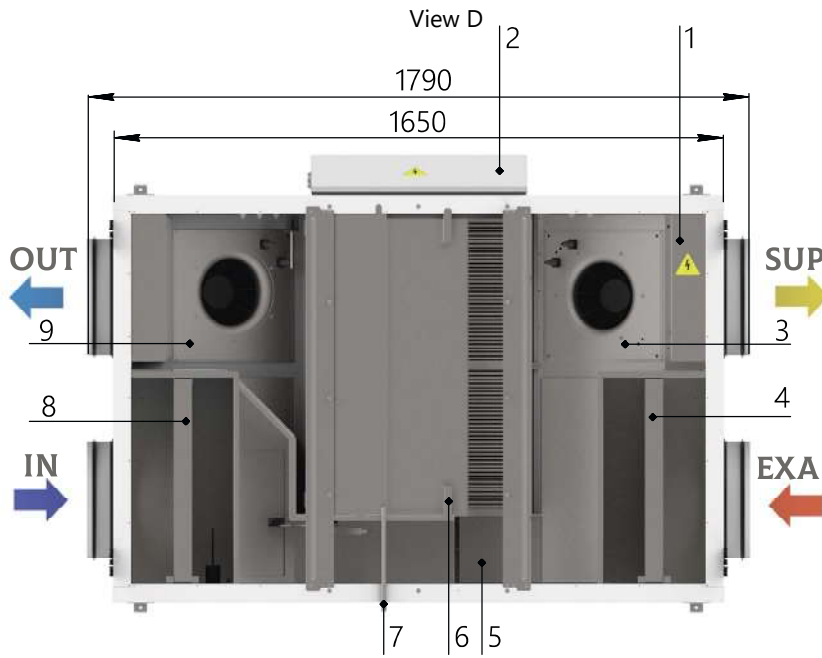

1. Electric air heater
2. Automation system unit
3. Supply air fan
4. Exhaust air filter
5. Bypass damper of recuperative heat exchanger
6. Counter-flow recuperative heat exchanger
7. Condensate drain
8. Supply air filter
9. Exhaust air fan

RIGHT-HAND VERSION

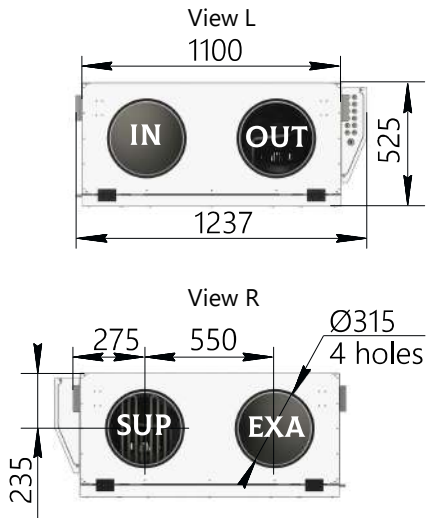

LEFT-HAND VERSION

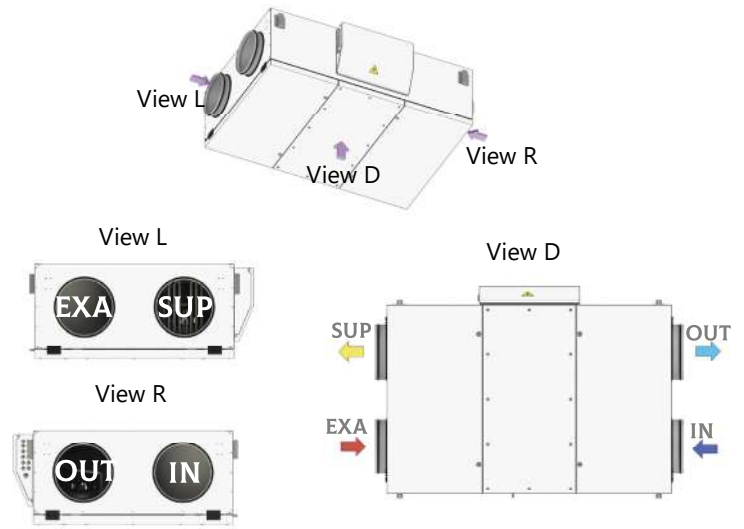

IN - outdoor air SUP - supply air EXA - exhaust air OUT - return air

AIR HANDLING UNITS

Parameter	VALUE
Nominal air-flow rate*, m ³ /h	900
External static pressure*, Pa	300
Maximum air flow rate (at static pressure 100 Pa), m ³ /h	1050
Supply voltage	~1 / 220 V / 50 Hz
Electric power of built-in electric heater, kW	3,3
Fan power (supply/exhaust), kW	0,26/0,26
Total electrical power of the AHU, kW	3,82
Filter (supply/exhaust)	M5/M5
Weight, kg, max	150

* The values are valid under normal conditions for both the supply and exhaust paths.



AEROSTART-EC-CF-900	Sound power level, dB								Total sound pressure level, dB(A)**
	Octave band mid-frequency, Hz*								
	63	125	250	500	1000	2000	4000	8000	
Input	56	54	47	49	46	40	35	27	50
Output	62	64	62	61	61	58	54	49	65
Surrounding	60	59	44	36	41	43	42	38	50

* At nominal flow rate and maximum fan speed.

** Total sound pressure level (not to be confused with power) at a distance of 3 meters.

AERODYNAMIC CHARACTERISTICS

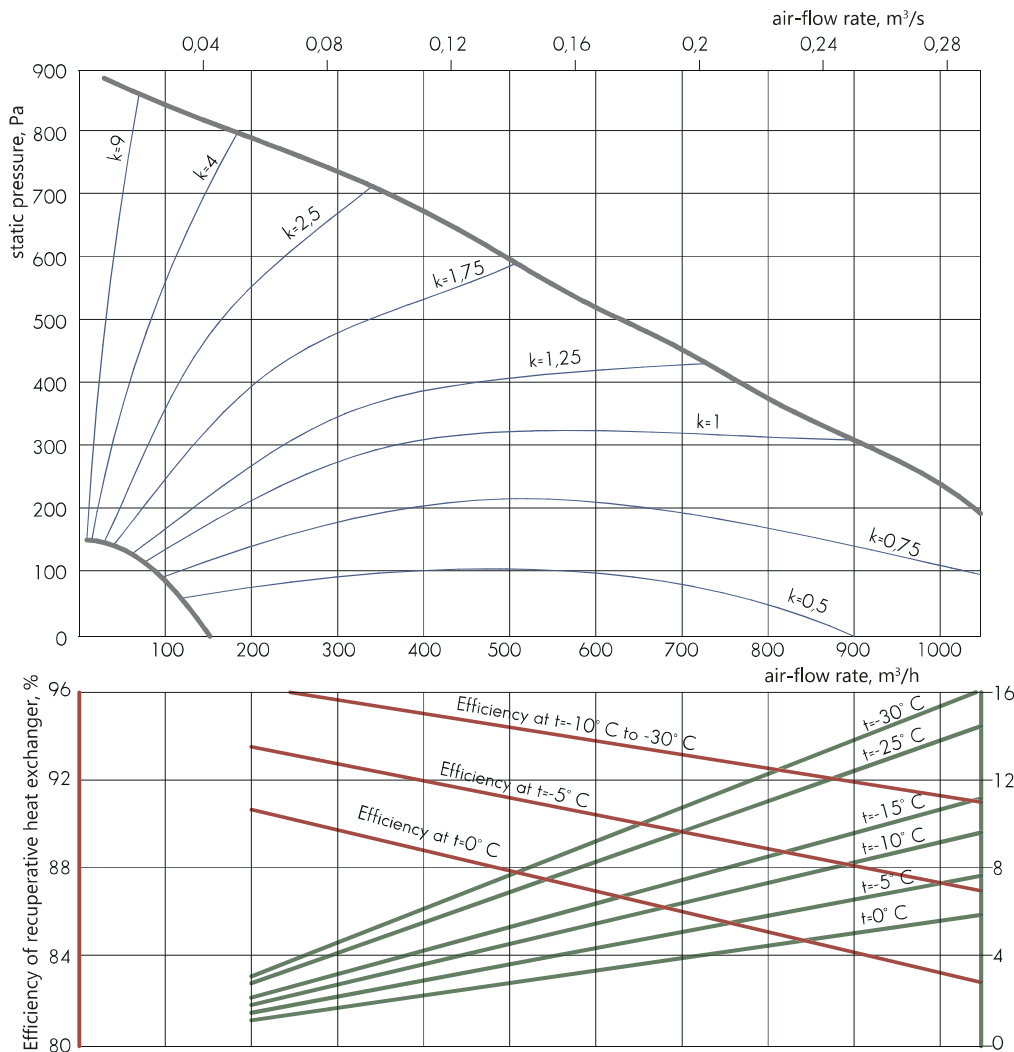

An example of using the aerodynamic characteristic and temperature efficiency graph is given above

TEMPERATURE EFFICIENCY

The temperature efficiency graph is shown at the same supply and exhaust air flow rates, and at the exhaust air temperature $t = +20^\circ\text{C}$, relative humidity $rh = 50\%$

- air valve
C-KVK-315
- insulated valve
C-GMK-C-40-20
- check valve
C-KOL-K-315
- single leaf damper
C-DKK-315
- duct silencer
C-GKK-315
- duct filter
C-FKK-315
- bag filter
C-FKK-315-BAG
- compact duct filter
C-FKK-L-315
- water/air-heater
C-KVN-K-315
- electric air heater
C-EVN-K-S3-315
- electric air heater
C-EVN-S3-40-20
- water/air-cooler
C-VKO-40-20
- Freon air cooler
C-FKO-40-20
- mounting clamp
C-MK-315
- adapter
AD-PSKK-400x200-315
- air intake grille
C-RVK-315
- exhaust grille
C-RVC-315
- supply and exhaust grille
C-RPVC-315
- non-adjustable grille
RKN-315
- water mixing unit
UWS

AIR HANDLING UNITS



AEROSTART-EC-CF-1300-G

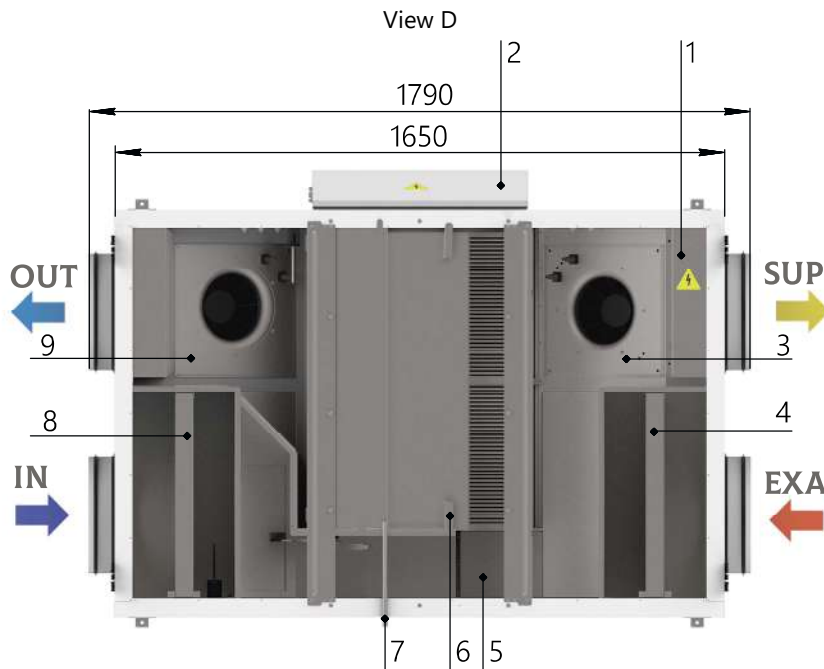

1. Electric air heater
2. Automation system unit
3. Supply air fan
4. Exhaust air filter
5. Bypass damper of recuperative heat exchanger
6. Counter-flow recuperative heat exchanger
7. Condensate drain
8. Supply air filter
9. Exhaust air fan

RIGHT-HAND VERSION

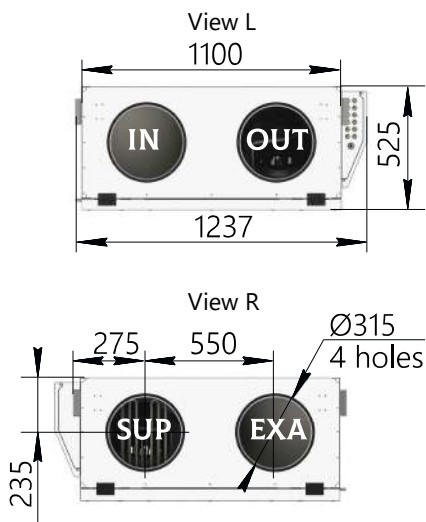

LEFT-HAND VERSION

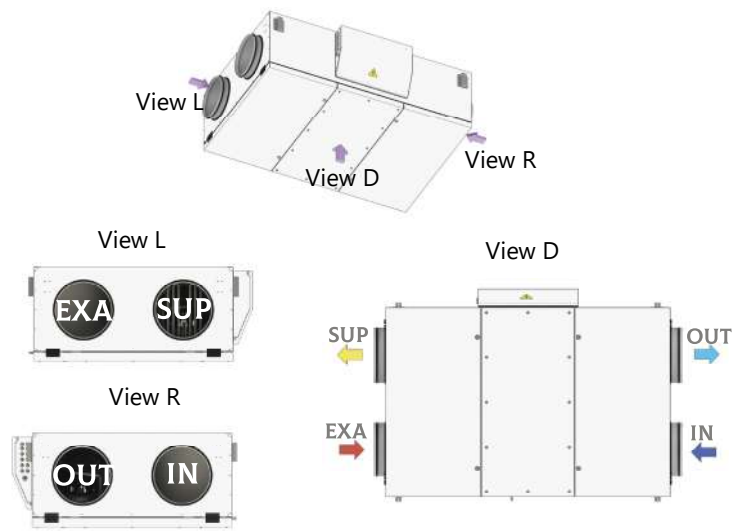

IN - outdoor air SUP - supply air EXA - exhaust air OUT - return air

Parameter	VALUE
Nominal air-flow rate*, m ³ /h	1300
External static pressure*, Pa	420
Maximum air flow rate (at static pressure 100 Pa), m ³ /h	1700
Supply voltage	~1 / 220 V / 50 Hz
Electric power of built-in electric heater, kW	5,0
Fan power (supply/exhaust), kW	0,5/0,5
Total electrical power of the AHU, kW	6
Filter (supply/exhaust)	M5/M5
Weight, kg, max	155

* The values are valid under normal conditions for both the supply and exhaust paths.

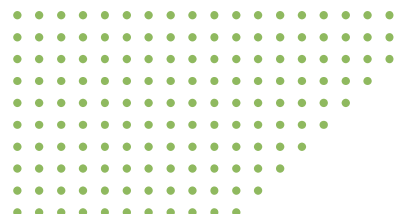



AEROSTART-EC-CF-1300	Sound power level, dB								Total sound pressure level, dB(A)**
	Octave band mid-frequency, Hz*								
	63	125	250	500	1000	2000	4000	8000	
Input	63	60	58	56	48	42	39	32	56
Output	69	70	73	68	63	60	58	54	70
Surrounding	67	65	55	43	43	45	46	43	54

* At nominal flow rate and maximum fan speed.

** Total sound pressure level (not to be confused with power) at a distance of 3 meters.

AERODYNAMIC CHARACTERISTICS

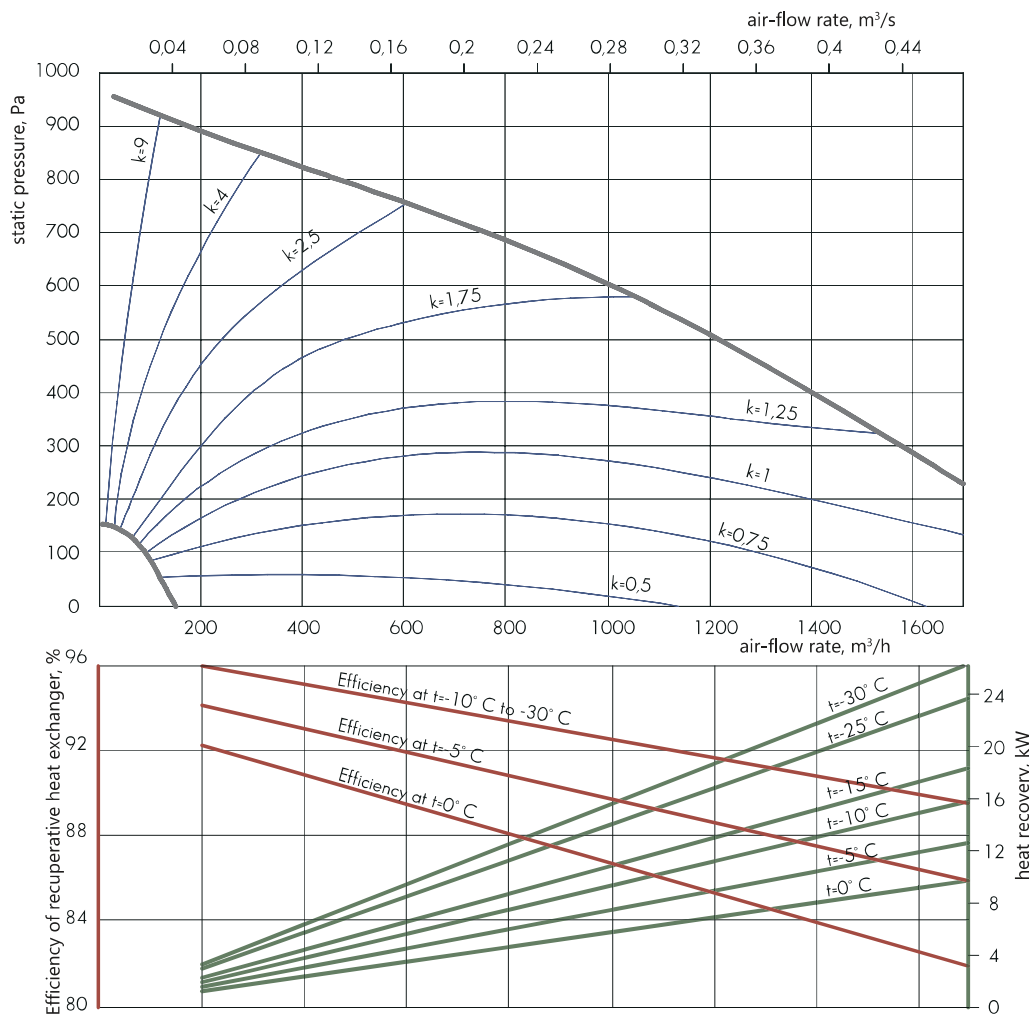

An example of using the aerodynamic characteristic and temperature efficiency graph is given above

TEMPERATURE EFFICIENCY

The temperature efficiency graph is shown at the same supply and exhaust air flow rates, and at the exhaust air temperature $t = +20^\circ\text{C}$, relative humidity $rh = 50\%$

- air valve
C-KVK-315
- insulated valve
C-GMK-C-50-25
- check valve
C-KOL-K-315
- single leaf damper
C-DKK-315
- duct silencer
C-GKK-315
- duct filter
C-FKK-315
- bag filter
C-FKK-315-BAG
- compact duct filter
C-FKK-L-315
- water/air-heater
C-KVN-K-315
- electric air heater
C-EVN-K-S3-315
- electric air heater
C-EVN-S3-50-25
- water/air-cooler
C-VKO-50-25
- Freon air cooler
C-FKO-50-25
- mounting clamp
C-MK-315
- adapter
AD-PSKK-500x250-315
- air intake grille
C-RVK-315
- exhaust grille
C-RVC-315
- supply and exhaust grille
C-RPVC-315
- non-adjustable grille
RKN-315
- water mixing unit
UWS



AEROSTART-EC-CF-2000-G

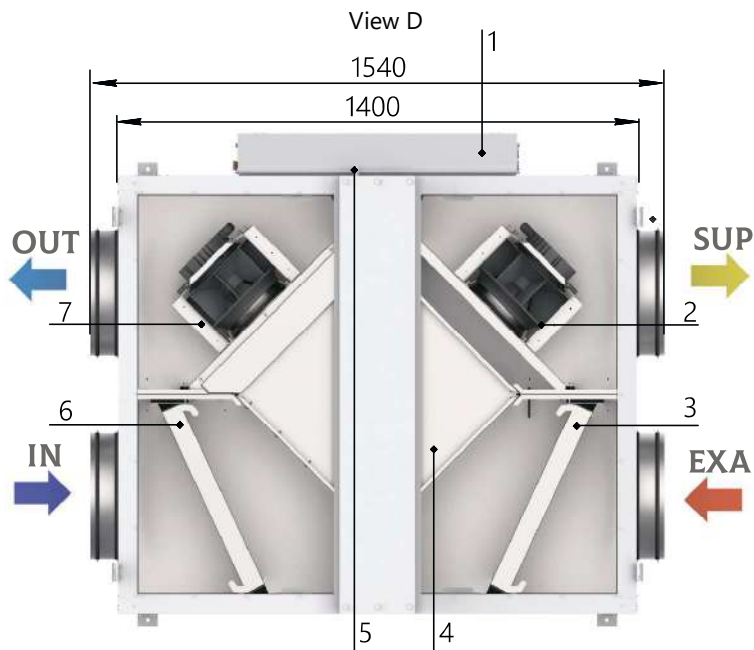

1. Automation system unit
2. Supply air fan
3. Exhaust air filter
4. Counter-flow recuperative heat exchanger
5. Condensate drain
6. Supply air filter
7. Exhaust air fan

RIGHT-HAND VERSION

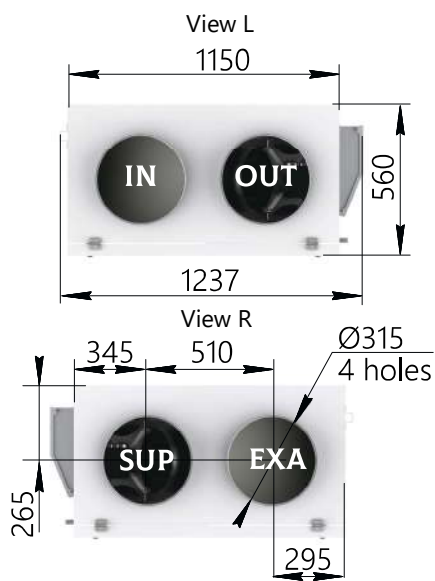

LEFT-HAND VERSION

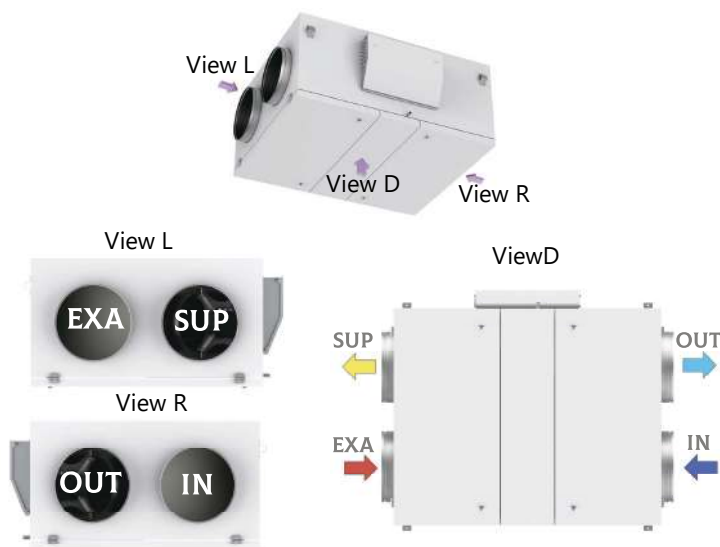

IN - outdoor air SUP - supply air EXA - exhaust air OUT - return air

Parameter	VALUE
Nominal air-flow rate*, m ³ /h	2 000
External static pressure*, Pa	240
Maximum air flow rate (at static pressure 200 Pa), m ³ /h	2 000
Supply voltage	~1 / 220 V / 50 Hz
Fan power (supply/exhaust), kW	0,5/0,5
Total electrical power of the AHU, kW	1
Filter (supply/exhaust)	M5/M5
Weight, kg, max	150

* The values are valid under normal conditions for both the supply and exhaust paths.



AEROSTART-EC-CF-2000	Sound power level, dB								Total sound pressure level, dB(A)**
	Octave band mid-frequency, Hz*								
	63	125	250	500	1000	2000	4000	8000	
Input	63	60	58	56	48	42	39	32	56
Output	69	70	73	68	63	60	58	54	70
Surrounding	67	65	55	43	43	45	46	43	54

* At nominal flow rate and maximum fan speed.

** Total sound pressure level (not to be confused with power) at a distance of 3 meters.

AERODYNAMIC CHARACTERISTICS

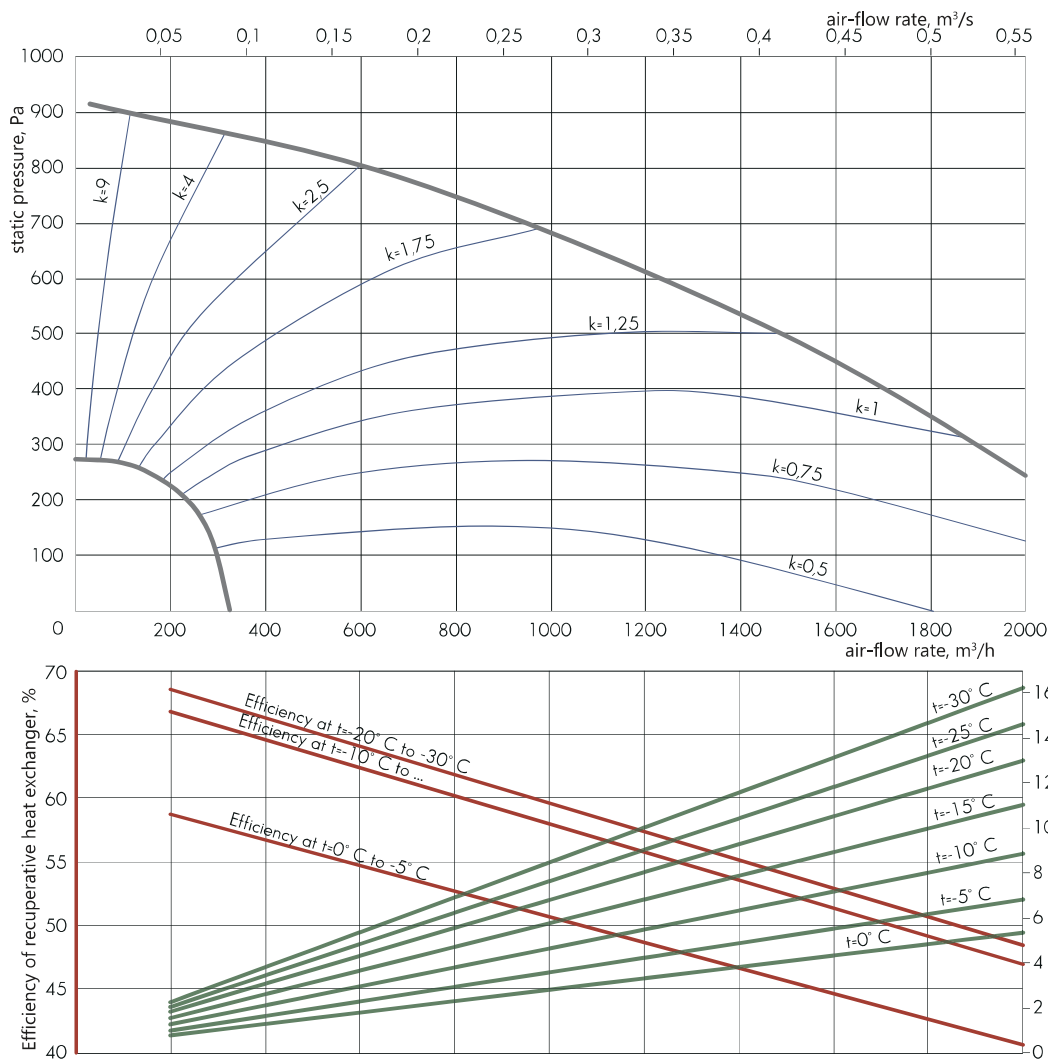

An example of using the aerodynamic characteristic and temperature efficiency graph is given above

TEMPERATURE EFFICIENCY

The temperature efficiency graph is shown at the same supply and exhaust air flow rates, and at the exhaust air temperature $t = +20^\circ\text{C}$, relative humidity $rh = 50\%$

- air valve
C-KVK-315
- insulated valve
C-GMK-C-50-30
- check valve
C-KOL-K-315
- single leaf damper
C-DKK-315
- duct silencer
C-GKK-315
- duct filter
C-FKK-315
- bag filter
C-FKK-315-BAG
- compact duct filter
C-FKK-L-315
- water/air-heater
C-KVN-50-30
- electric air heater
C-EVN-K-S3-315
- electric air heater
C-EVN-S3-50-30
- water/air-cooler
C-VKO-50-30
- Freon air cooler
C-FKO-50-30
- mounting clamp
C-MK-315
- adapter
AD-PSKK-500x300-315
- air intake grille
C-RVK-315
- exhaust grille
C-RVC-315
- supply and exhaust grille
C-RPVC-315
- non-adjustable grille
RKN-315
- water mixing unit
UWS



AEROSTART-EC-CF-3000-G

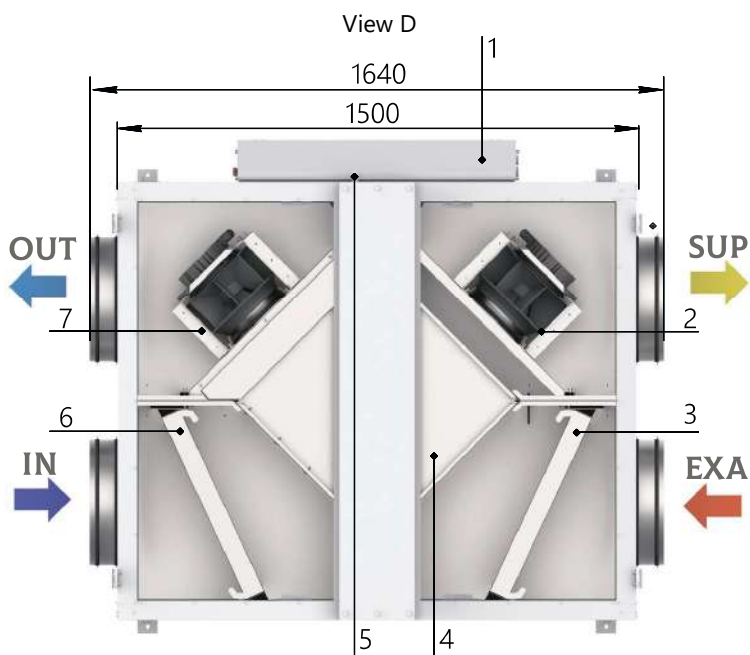

- 1. Automation system unit
- 2. Supply air fan
- 3. Exhaust air filter
- 4. Counter-flow recuperative heat exchanger
- 5. Condensate drain
- 6. Supply air filter
- 7. Exhaust air fan

RIGHT-HAND VERSION

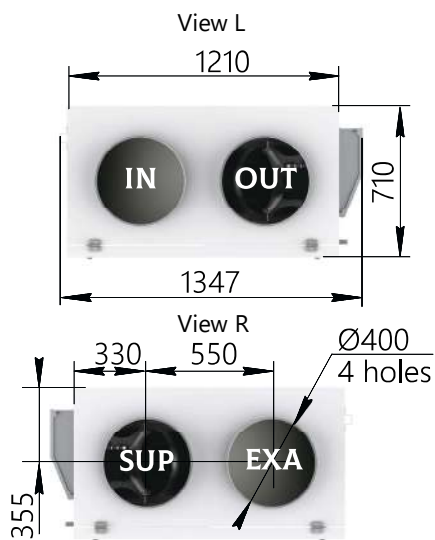

LEFT-HAND VERSION

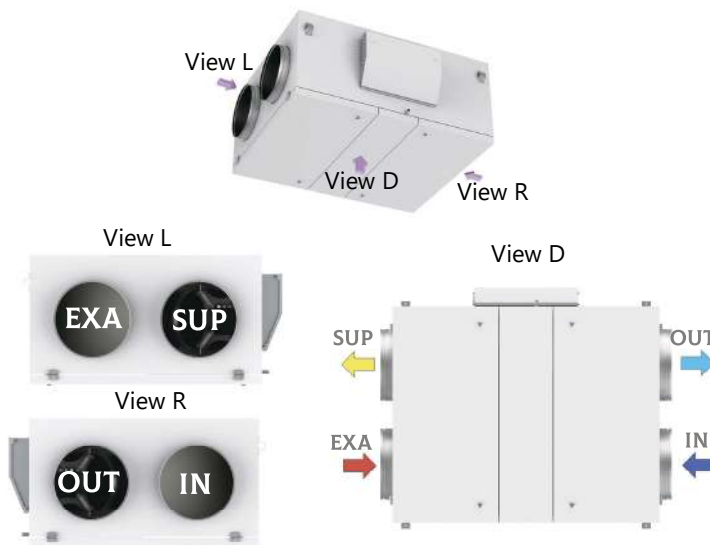

IN - outdoor air SUP - supply air EXA - exhaust air OUT - return air

AIR HANDLING UNITS

Parameter	VALUE
Nominal air-flow rate*, m ³ /h	3 000
External static pressure*, Pa	275
Maximum air flow rate (at static pressure 200 Pa), m ³ /h	3 100
Supply voltage	~3 / 380 V / 50 Hz
Fan power (supply/exhaust), kW	1/1
Total electrical power of the AHU, kW	2
Filter (supply/exhaust)	M5/M5
Weight, kg, max	190

* The values are valid under normal conditions for both the supply and exhaust paths.

AEROSTART-EC-CF-3000	Sound power level, dB								Total sound pressure level, dB(A)**
	Octave band mid-frequency, Hz*								
	63	125	250	500	1000	2000	4000	8000	
Input	60	55	68	65	62	61	59	54	68
Output	63	57	70	68	70	68	64	59	74
Surrounding	61	52	52	43	50	53	52	48	58

* At nominal flow rate and maximum fan speed.

** Total sound pressure level (not to be confused with power) at a distance of 3 meters.

AERODYNAMIC CHARACTERISTICS

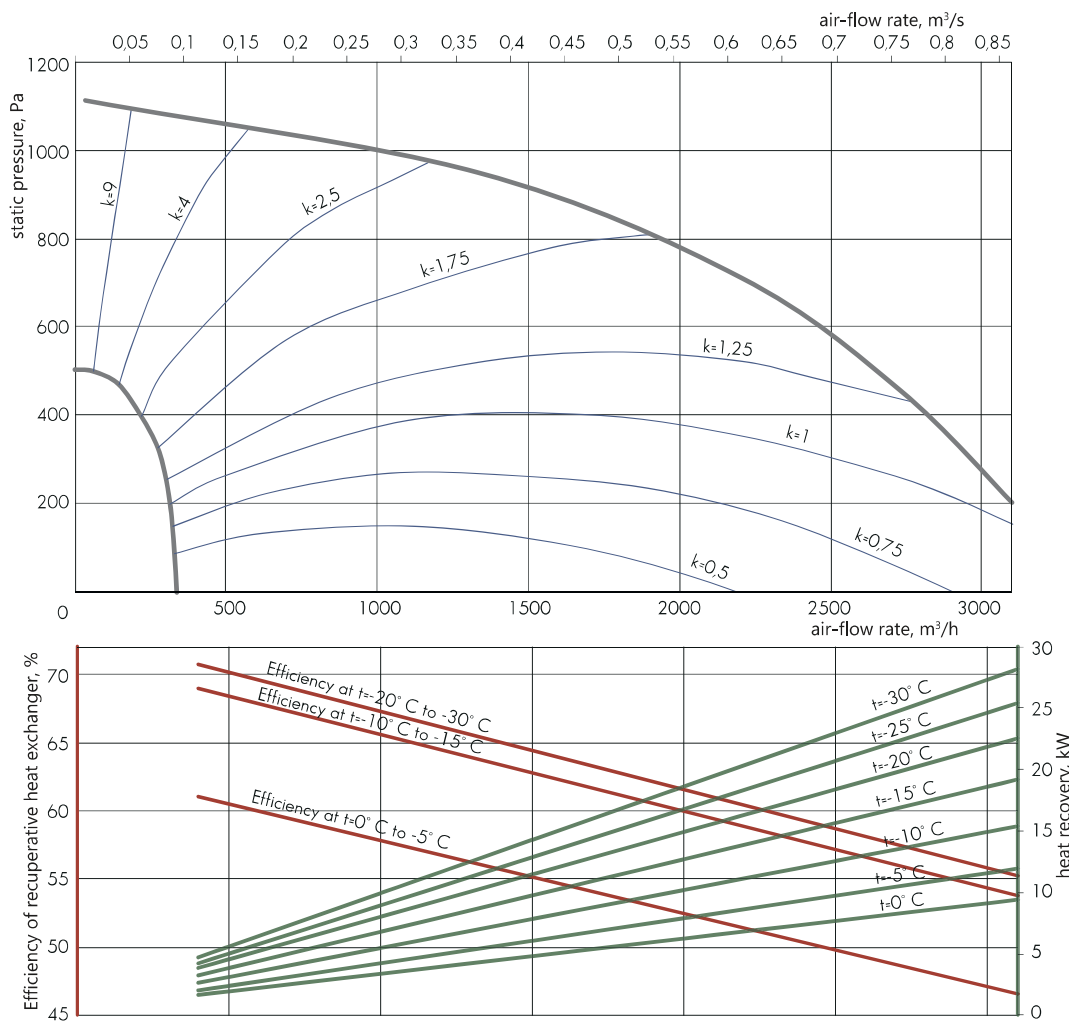

An example of using the aerodynamic characteristic and temperature efficiency graph is given above

TEMPERATURE EFFICIENCY

The temperature efficiency graph is shown at the same supply and exhaust air flow rates, and at the exhaust air temperature $t = +20^\circ\text{C}$, relative humidity $rh = 50\%$

- air valve
C-KVK-400
- insulated valve
C-GMK-C-60-35
- check valve
C-KOL-K-400
- single leaf damper
C-DKK-400
- duct silencer
C-GKK-400
- duct filter
C-FKK-400
- bag filter
C-FKK-400-BAG
- compact duct filter
C-FKK-L-400
- water/air-heater
C-KVN-60-35
- electric air heater
C-EVN-K-S3-400
- electric air heater
C-EVN-S3-60-35
- water/air-cooler
C-VKO-60-35
- Freon air cooler
C-FKO-60-35
- mounting clamp
C-MK-400
- adapter
AD-PSKK-600x350-400
- air intake grille
C-RVK-400
- exhaust grille
C-RVC-400
- supply and exhaust grille
C-RPVC-400
- non-adjustable grille
RKN-400
- water mixing unit
UWS

AEROSTART-EC-CF-4000-G

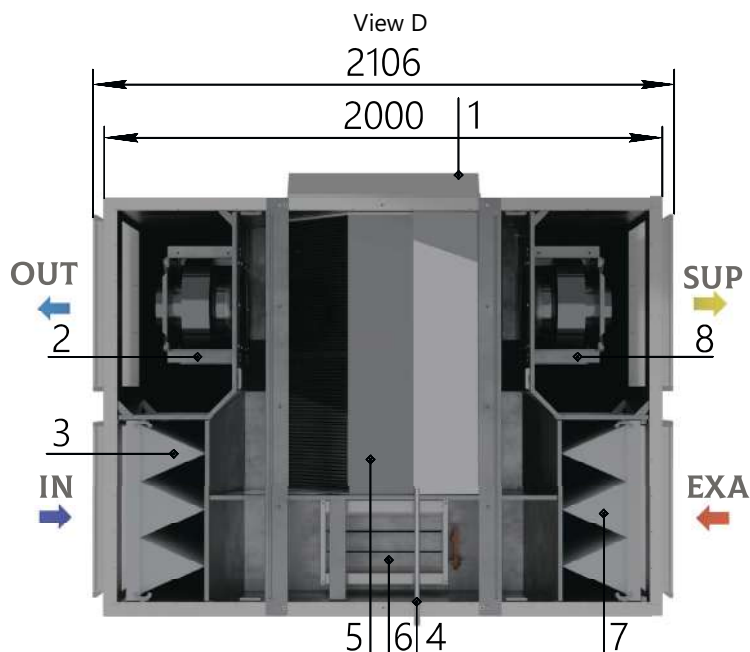

- 1. Automation system unit
- 2. Supply air fan
- 3. Supply air filter
- 4. Condensate drain
- 5. Recuperative heat exchanger
- 6. Bypass damper of recuperative heat exchanger
- 7. Exhaust air filter
- 8. Exhaust air fan

RIGHT-HAND VERSION

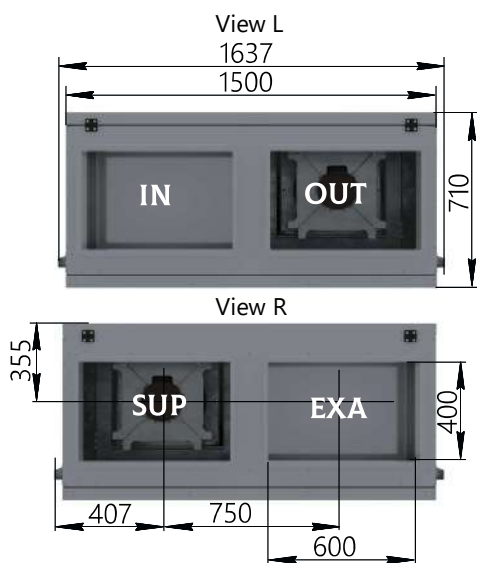

LEFT-HAND VERSION

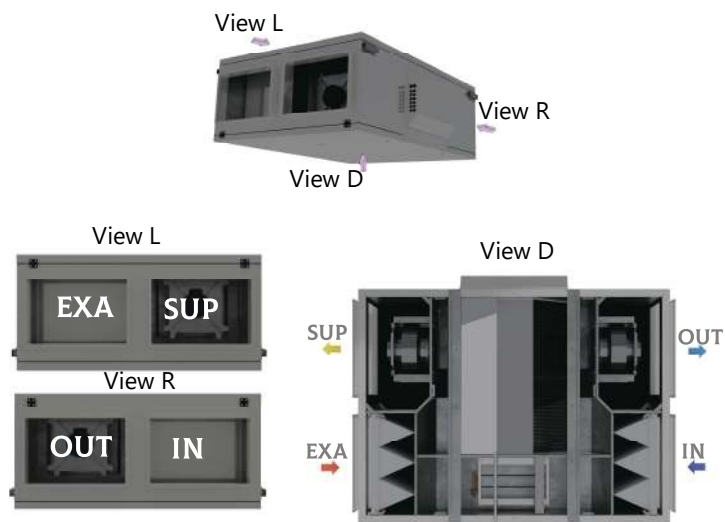

IN - outdoor air SUP - supply air EXA - exhaust air OUT - return air

AIR HANDLING UNITS

Parameter	VALUE
Nominal air-flow rate*, m ³ /h	4 000
External static pressure*, Pa	360
Maximum air flow rate (at static pressure 200 Pa), m ³ /h	4 250
Supply voltage	~3 / 380 V / 50 Hz
Fan power (supply/exhaust), kW	1,32/1,32
Total electrical power of the AHU, kW	2,64
Filter (supply/exhaust)	M5/M5
Weight, kg, max	352

* The values are valid under normal conditions for both the supply and exhaust paths.



AEROSTART-EC-CF-4000	Sound power level, dB								Total sound pressure level, dB(A)**
	Octave band mid-frequency, Hz*								
	63	125	250	500	1000	2000	4000	8000	
Input	49	48	56	56	52	51	48	44	58
Output	50	50	60	59	62	60	55	52	66
Surrounding	51	48	45	37	45	48	46	44	53

* At nominal flow rate and maximum fan speed.

** Total sound pressure level (not to be confused with power) at a distance of 3 meters.

AERODYNAMIC CHARACTERISTICS

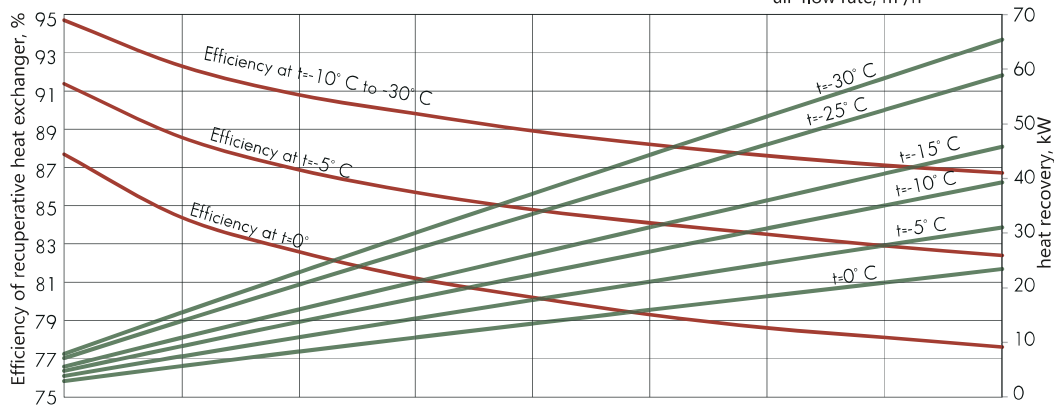
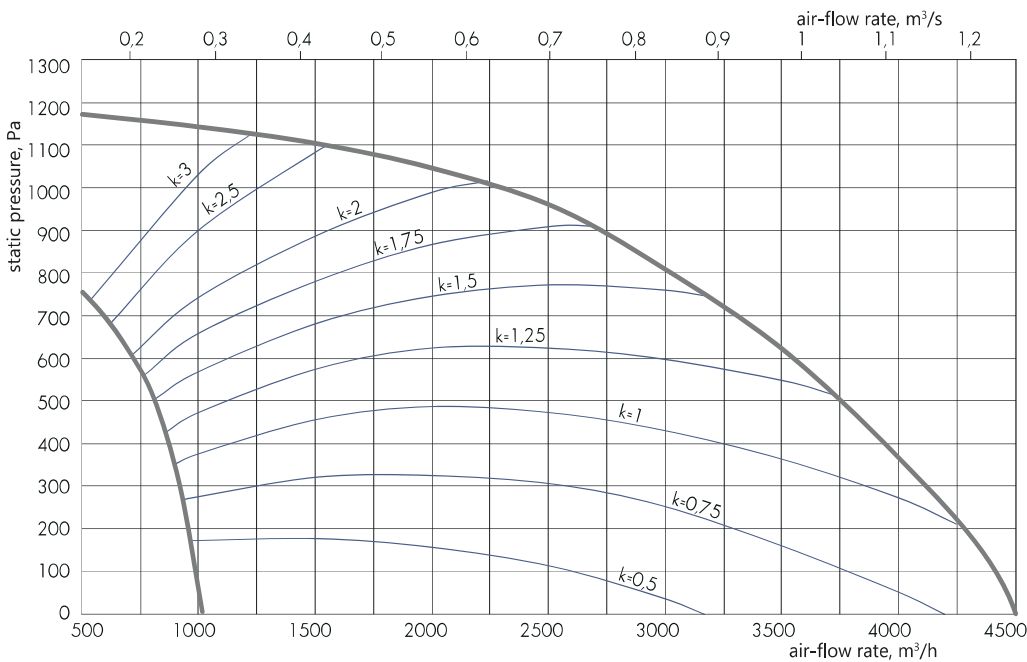

An example of using the aerodynamic characteristic and temperature efficiency graph is given above

TEMPERATURE EFFICIENCY

The temperature efficiency graph is shown at the same supply and exhaust air flow rates, and at the exhaust air temperature $t = +20^\circ\text{C}$, relative humidity $rh = 50\%$

universal air valve

C-REG-80-50

air valve

C-GMK-P-80-50

insulated valve

C-GMK-C-80-50

check valve

C-KOL-80-50

duct silencer

C-GKP-80-50

duct filter

C-FKP-80-50

water/air-heater

C-KVN-80-50

electric air heater

C-EVN-80-50

water/air-cooler

C-VKO-80-50

Freon air cooler

C-FKO-80-50

duct silencer

C-GKD-80-50

adapter

AD-PDK-600x400-800x500

non-adjustable grille

C-RKO-80-50

non-adjustable grille

C-RKA-80-50

water mixing unit

UWS



AEROSTART-EC-CF-5000-G

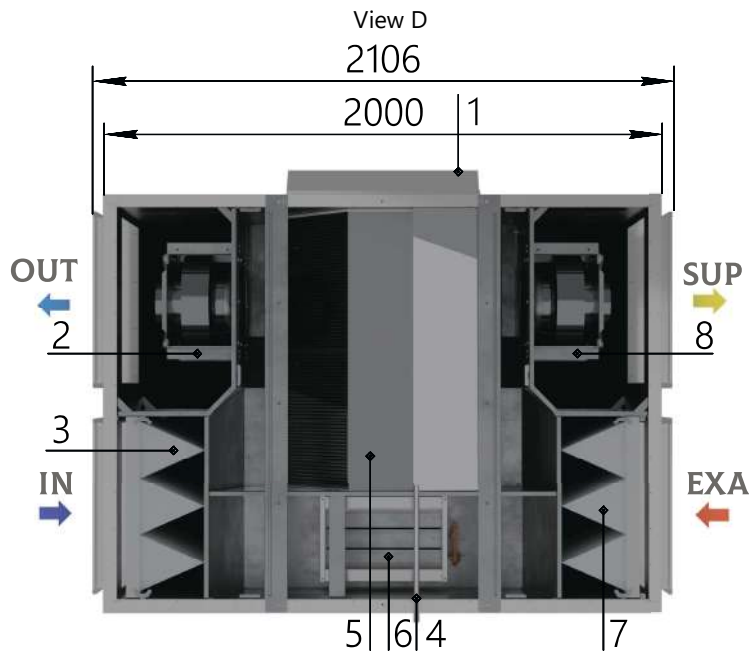

- 1. Automation system unit
- 2. Supply air fan
- 3. Supply air filter
- 4. Condensate drain
- 5. Recuperative heat exchanger
- 6. Bypass damper of recuperative heat exchanger
- 7. Exhaust air filter
- 8. Exhaust air fan

RIGHT-HAND VERSION

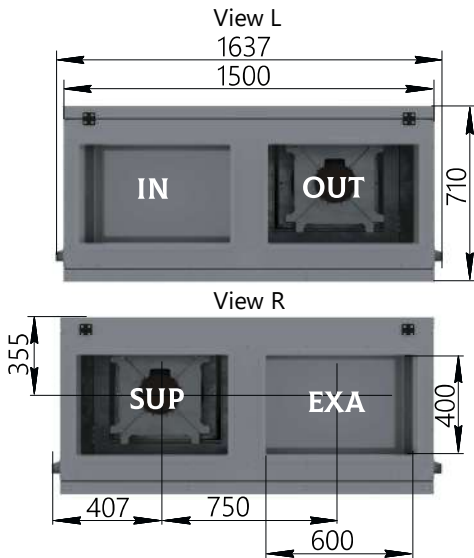

LEFT-HAND VERSION

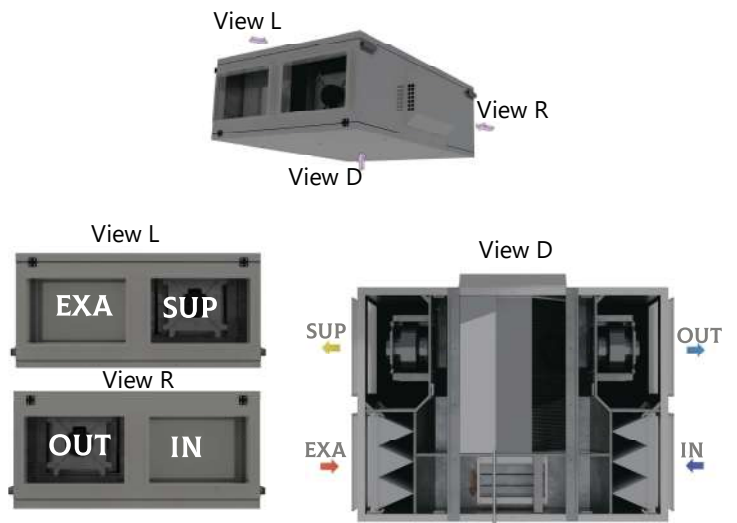

IN - outdoor air SUP - supply air EXA - exhaust air OUT - return air

AIR HANDLING UNITS

Parameter	VALUE
Nominal air-flow rate*, m ³ /h	5 000
External static pressure*, Pa	550
Maximum air flow rate (at static pressure 200 Pa), m ³ /h	5 400
Supply voltage	~3 / 380 V / 50 Hz
Fan power (supply/exhaust), kW	2,5/2,5
Total electrical power of the AHU, kW	5
Filter (supply/exhaust)	M5/M5
Weight, kg, max	352

* The values are valid under normal conditions for both the supply and exhaust paths.



AEROSTART-EC-CF-5000	Sound power level, dB								Загальний Total sound pressure level, dB(A)**
	Octave band mid-frequency, Hz*								
	63	125	250	500	1000	2000	4000	8000	
Input	56	50	56	62	57	57	54	50	64
Output	56	53	60	65	68	66	61	58	72
Surrounding	57	51	45	43	51	54	52	50	59

* At nominal flow rate and maximum fan speed.

** Total sound pressure level (not to be confused with power) at a distance of 3 meters.

AERODYNAMIC CHARACTERISTICS

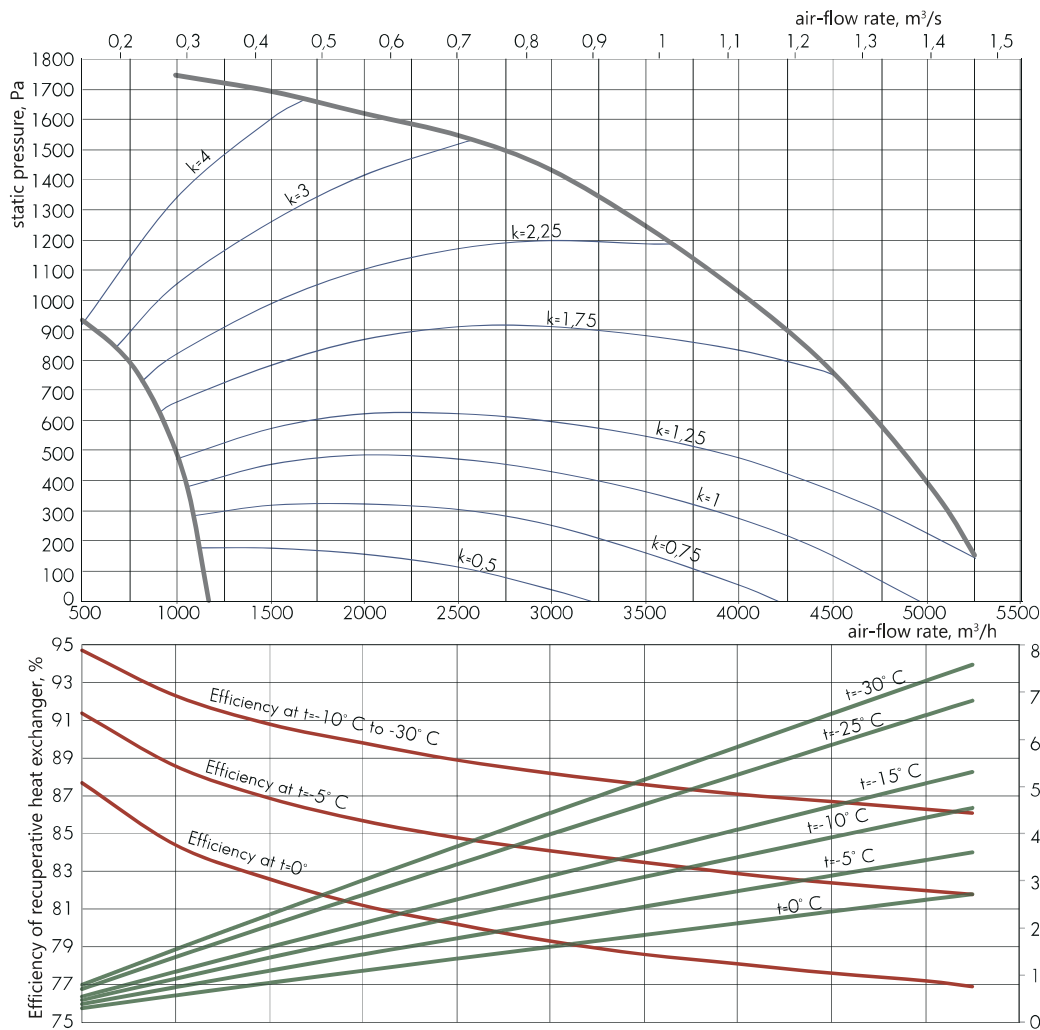

An example of using the aerodynamic characteristic and temperature efficiency graph is given above

TEMPERATURE EFFICIENCY

The temperature efficiency graph is shown at the same supply and exhaust air flow rates, and at the exhaust air temperature $t = +20^\circ\text{C}$, relative humidity $rh = 50\%$

universal air valve

C-REG-80-50

air valve

C-GMK-P-80-50

insulated valve

C-GMK-C-80-50

check valve

C-KOL-80-50

duct silencer

C-GKP-80-50

duct filter

C-FKP-80-50

water/air-heater

C-KVN-80-50

electric air heater

C-EVN-80-50

water/air-cooler

C-VKO-80-50

Freon air cooler

C-FKO-80-50

duct silencer

C-GKD-80-50

adapter

AD-PDK-600x400-800x500

non-adjustable grille

C-RKO-80-50

non-adjustable grille

C-RKA-80-50

water mixing unit

UWS



AEROSTART-EC-CF-250-H

RIGHT-HAND VERSION

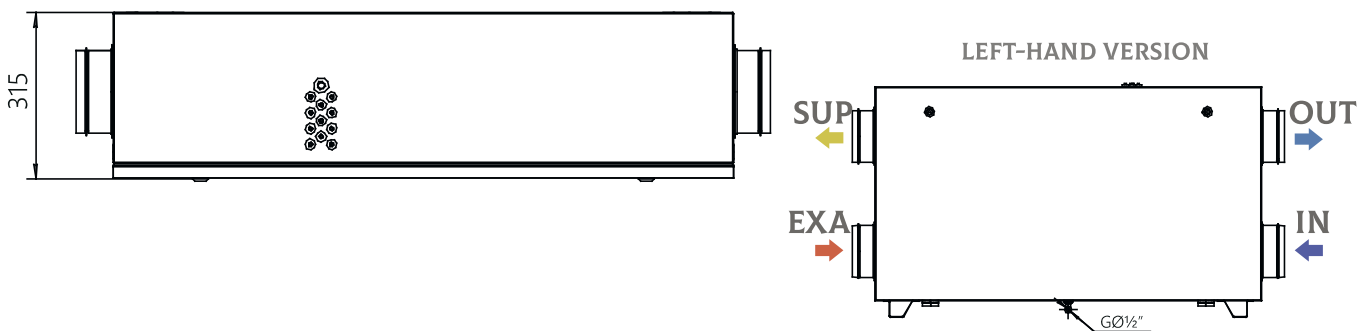
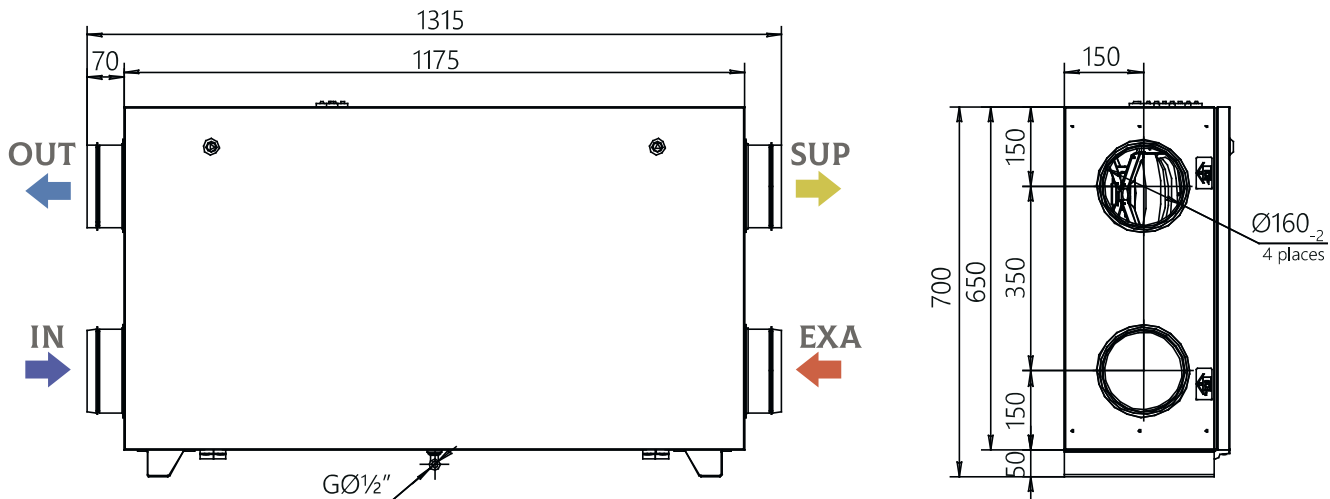

IN - outdoor air SUP - supply air EXA - exhaust air OUT - return air

Parameter	VALUE
Nominal air-flow rate*, m ³ /h	250
External static pressure*, Pa	278
Maximum air flow rate (at static pressure 100 Pa), m ³ /h	340
Supply voltage	~1 / 220 V / 50 Hz
Electric power of built-in electric heater, kW	0,9
Fan power (supply/exhaust), kW	0,08/0,08
Total electrical power of the AHU, kW	1,07
Filter (supply/exhaust)	M5/M5
Weight, kg, max	58

* The values are valid under normal conditions for both the supply and exhaust paths.



AEROSTART-EC-CF-250	Sound power level, dB								Total sound pressure level, dB(A)**
	Octave band mid-frequency, Hz*								
	63	125	250	500	1000	2000	4000	8000	
Input	49	48	48	50	43	38	32	26	49
Output	55	58	63	62	58	56	51	48	64
Surrounding	53	53	45	37	38	41	39	37	47

* At nominal flow rate and maximum fan speed.

** Total sound pressure level (not to be confused with power) at a distance of 3 meters.

AERODYNAMIC CHARACTERISTICS

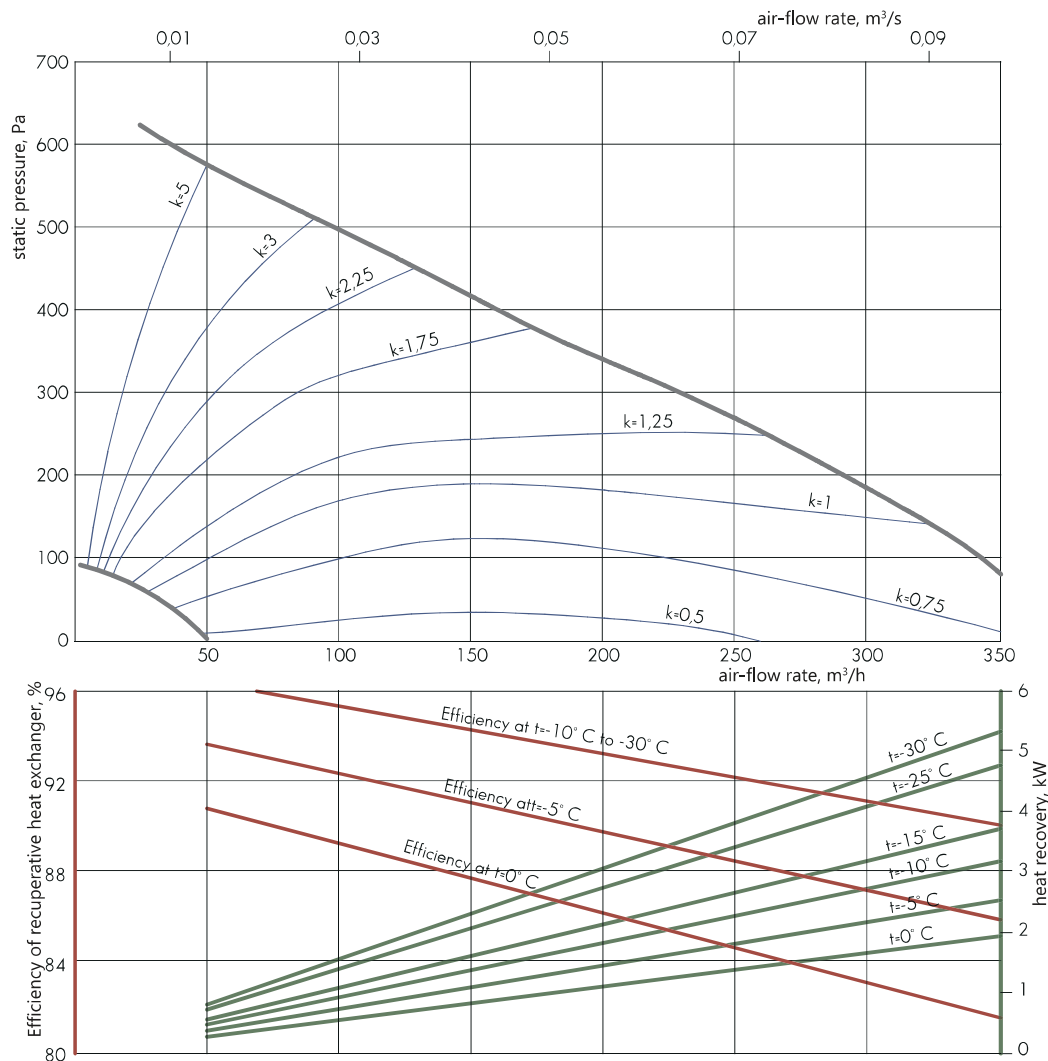

An example of using the aerodynamic characteristic and temperature efficiency graph is given above

TEMPERATURE EFFICIENCY

The temperature efficiency graph is shown at the same supply and exhaust air flow rates, and at the exhaust air temperature $t = +20^\circ\text{C}$, relative humidity $rh = 50\%$



- air valve
C-KVK-160
- insulated valve
C-GMK-C-40-20
- check valve
C-KOL-K-160
- single leaf damper
C-DKK-160
- duct silencer
C-GKK-160
- duct filter
C-FKK-160
- bag filter
C-FKK-160-BAG
- compact duct filter
C-FKK-L-160
- water/air-heater
C-KVN-K-160
- electric air heater
C-EVN-K-S3-160
- electric air heater
C-EVN-S3-40-20
- water/air-cooler
C-VKO-40-20
- Freon air cooler
C-FKO-40-20
- mounting clamp
C-MK-160
- adapter
AD-PSKK-400x200-160
- air intake grille
C-RVK-160
- exhaust grille
C-RVC-160
- supply and exhaust grille
C-RPVC-160
- non-adjustable grille
RKN-160
- water mixing unit
UWS

AIR HANDLING UNITS



AEROSTART-EC-CF-550-H

RIGHT-HAND VERSION

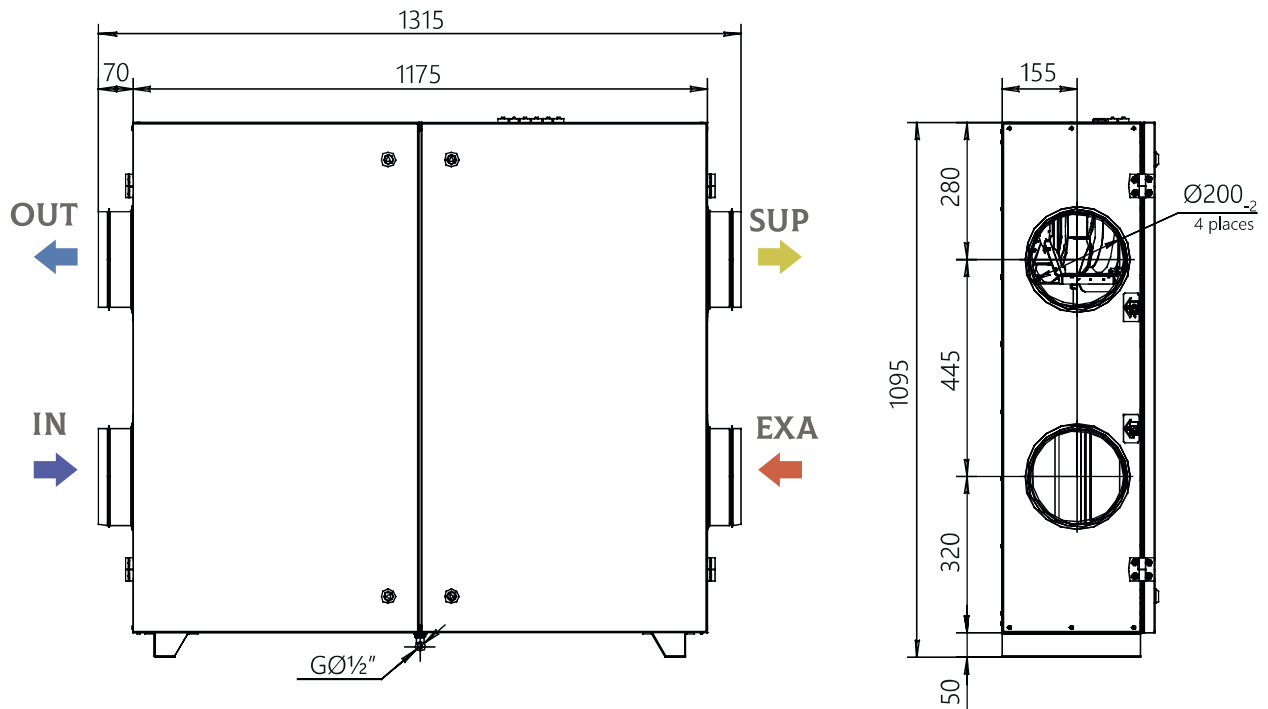

LEFT-HAND VERSION

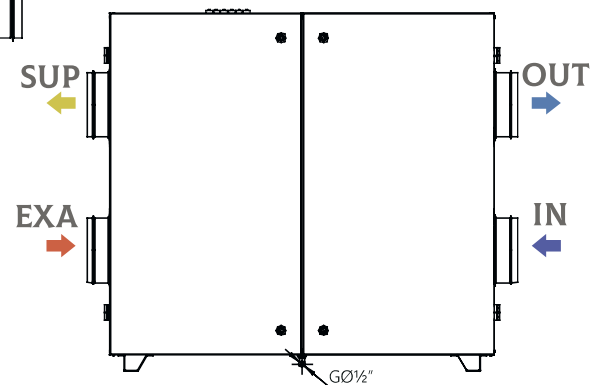

IN - outdoor air SUP - supply air EXA - exhaust air OUT - return air

Parameter	VALUE
Nominal air-flow rate*, m ³ /h	550
External static pressure*, Pa	240
Maximum air flow rate (at static pressure 100 Pa), m ³ /h	700
Supply voltage	~1 / 220 V / 50 Hz
Electric power of built-in electric heater, kW	2,0
Fan power (supply/exhaust), kW	0,17/0,17
Total electrical power of the AHU, kW	2,34
Filter (supply/exhaust)	M5/M5
Weight, kg, max	93

* The values are valid under normal conditions for both the supply and exhaust paths.

AEROSTART-EC-CF-550	Sound power level, dB								Total sound pressure level, dB(A)**
	Octave band mid-frequency, Hz*								
	63	125	250	500	1000	2000	4000	8000	
Input	43	42	41	46	44	41	37	32	48
Output	49	52	56	58	59	59	56	54	65
Surrounding	47	47	38	33	39	44	44	43	50

* At nominal flow rate and maximum fan speed.

** Total sound pressure level (not to be confused with power) at a distance of 3 meters.

AERODYNAMIC CHARACTERISTICS

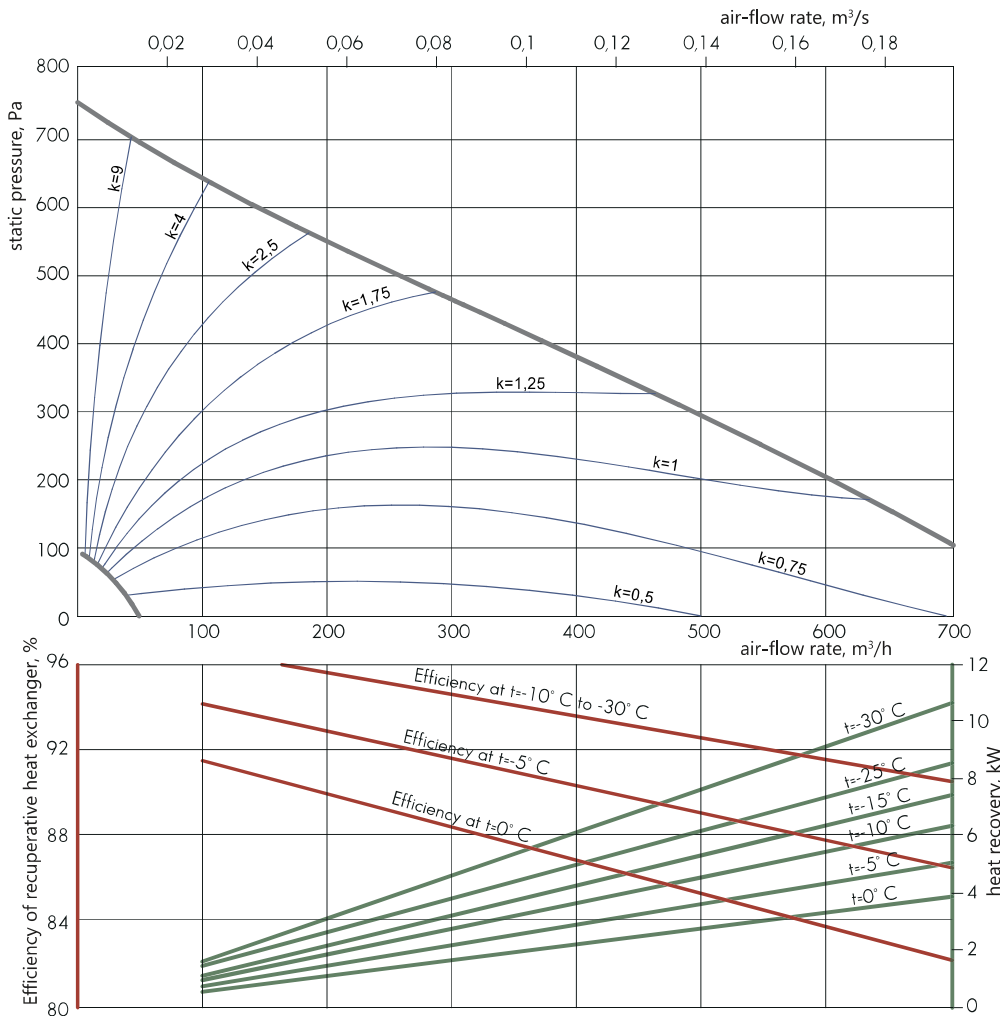

An example of using the aerodynamic characteristic and temperature efficiency graph is given above

TEMPERATURE EFFICIENCY

The temperature efficiency graph is shown at the same supply and exhaust air flow rates, and at the exhaust air temperature $t = +20^\circ\text{C}$, relative humidity $rh = 50\%$

- air valve
C-KVK-200
- insulated valve
C-GMK-C-40-20
- check valve
C-KOL-K-200
- single leaf damper
C-DKK-200
- duct silencer
C-GKK-200
- duct filter
C-FKK-200
- bag filter
C-FKK-200-BAG
- compact duct filter
C-FKK-L-200
- water/air-heater
C-KVN-K-200
- electric air heater
C-EVN-K-S3-200
- electric air heater
C-EVN-S3-40-20
- water/air-cooler
C-VKO-40-20
- Freon air cooler
C-FKO-40-20
- mounting clamp
C-MK-200
- adapter
AD-PSKK-400x200-200
- air intake grille
C-RVK-200
- exhaust grille
C-RVC-200
- supply and exhaust grille
C-RPVC-200
- non-adjustable grille
RKN-200
- water mixing unit
UWS

AIR HANDLING UNITS

AEROSTART-EC-CF-900-H

RIGHT-HAND VERSION

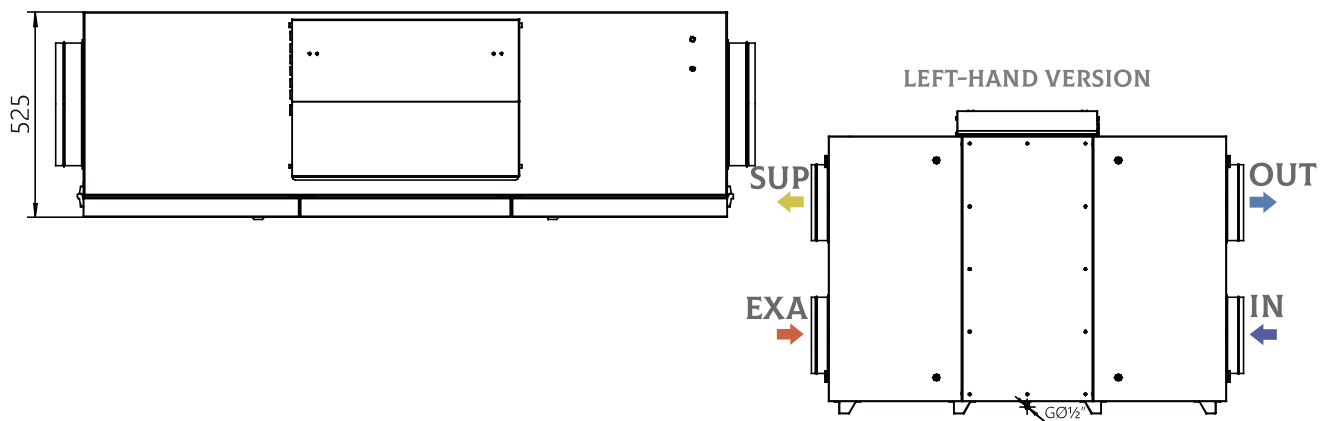
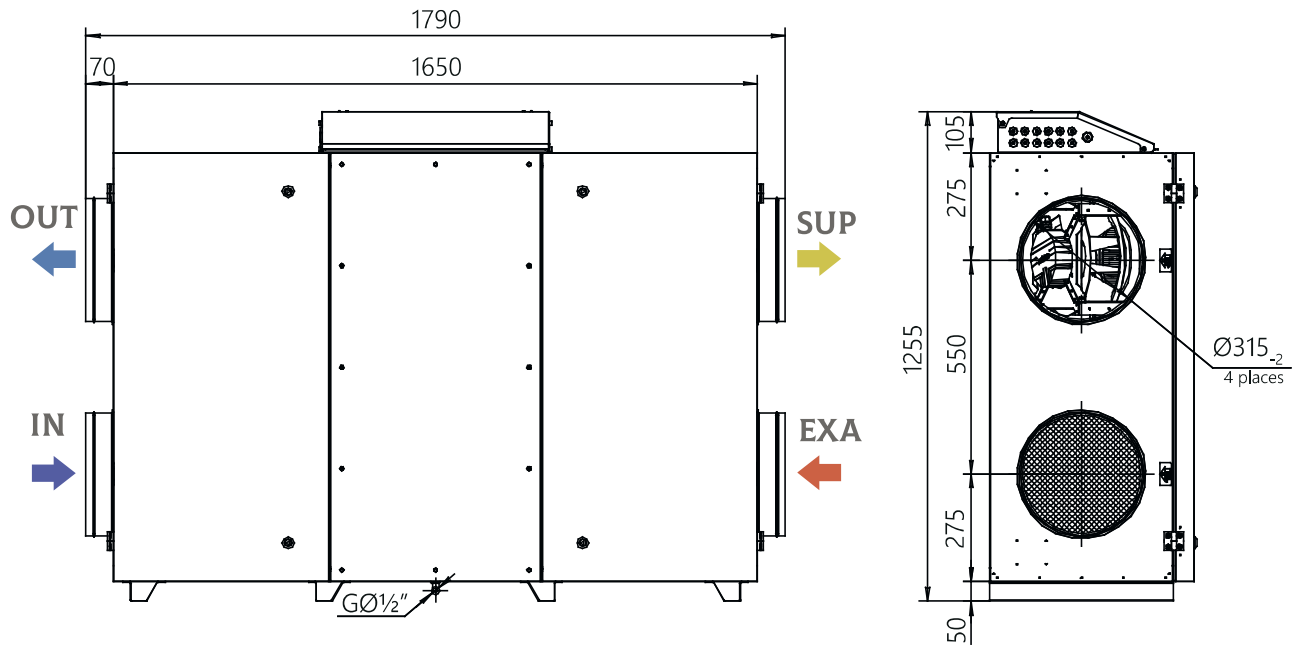

LEFT-HAND VERSION

IN - outdoor air SUP - supply air EXA - exhaust air OUT - return air

Parameter	VALUE
Nominal air-flow rate*, m ³ /h	900
External static pressure*, Pa	300
Maximum air flow rate (at static pressure 100 Pa), m ³ /h	1050
Supply voltage	~1 / 220 V / 50 Hz
Electric power of built-in electric heater, kW	3,3
Fan power (supply/exhaust), kW	0,26/0,26
Total electrical power of the AHU, kW	3,82
Filter (supply/exhaust)	M5/M5
Weight, kg, max	150

* The values are valid under normal conditions for both the supply and exhaust paths.



AEROSTART-EC-CF-900	Sound power level, dB								Total sound pressure level, dB(A)**
	Octave band mid-frequency, Hz*								
	63	125	250	500	1000	2000	4000	8000	
Input	56	54	47	49	46	40	35	27	50
Output	62	64	62	61	61	58	54	49	65
Surrounding	60	59	44	36	41	43	42	38	50

* At nominal flow rate and maximum fan speed.

** Total sound pressure level (not to be confused with power) at a distance of 3 meters.

AERODYNAMIC CHARACTERISTICS

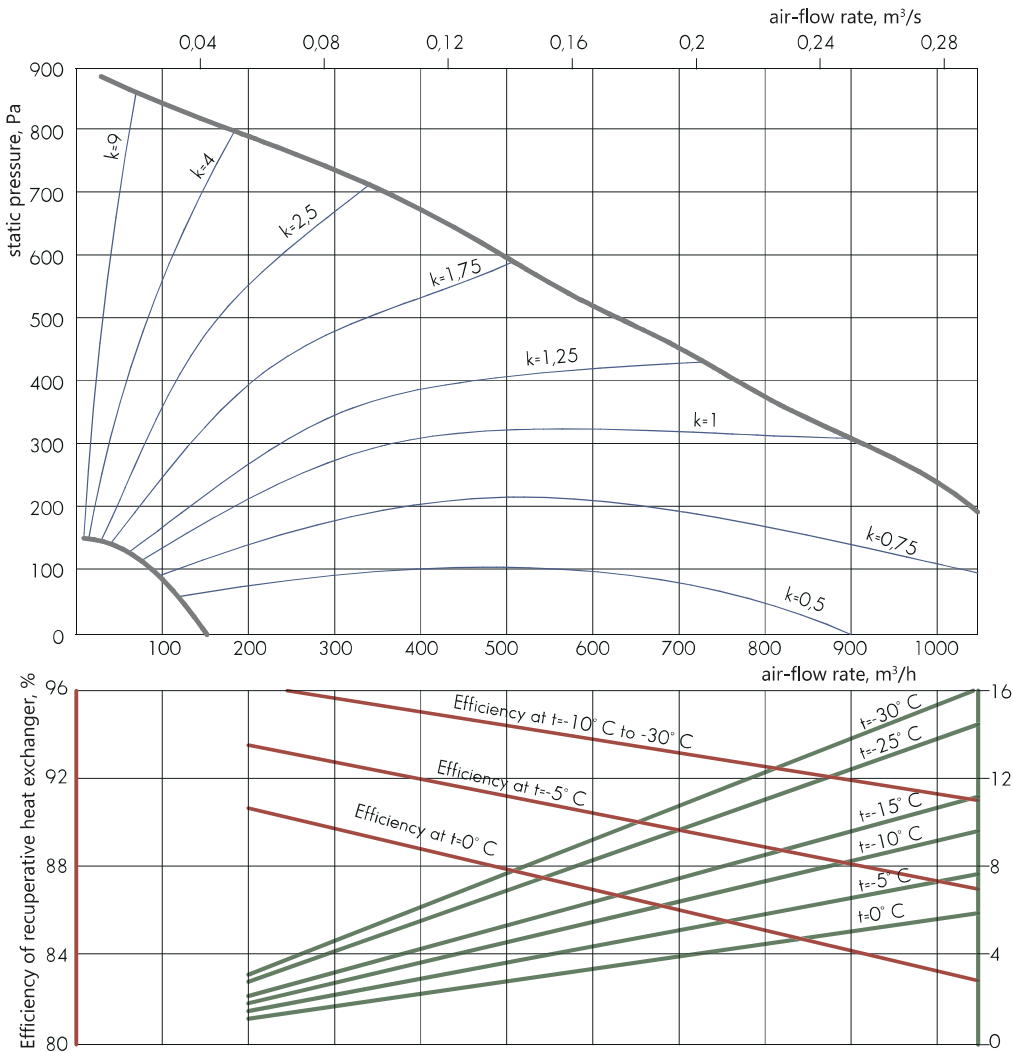

An example of using the aerodynamic characteristic and temperature efficiency graph is given above

TEMPERATURE EFFICIENCY

The temperature efficiency graph is shown at the same supply and exhaust air flow rates, and at the exhaust air temperature $t = +20^\circ\text{C}$, relative humidity $rh = 50\%$

- air valve
C-KVK-315
- insulated valve
C-GMK-C-40-20
- check valve
C-KOL-K-315
- single leaf damper
C-DKK-315
- duct silencer
C-GKK-315
- duct filter
C-FKK-315
- bag filter
C-FKK-315-BAG
- compact duct filter
C-FKK-L-315
- water/air-heater
C-KVN-K-315
- electric air heater
C-EVN-K-S3-315
- electric air heater
C-EVN-S3-40-20
- water/air-cooler
C-VKO-40-20
- Freon air cooler
C-FKO-40-20
- mounting clamp
C-MK-315
- adapter
AD-PSKK-400x200-315
- air intake grille
C-RVK-315
- exhaust grille
C-RVC-315
- supply and exhaust grille
C-RPVC-315
- non-adjustable grille
RKN-315
- water mixing unit
UWS

AIR HANDLING UNITS



AEROSTART-EC-CF-1300-H

RIGHT-HAND VERSION

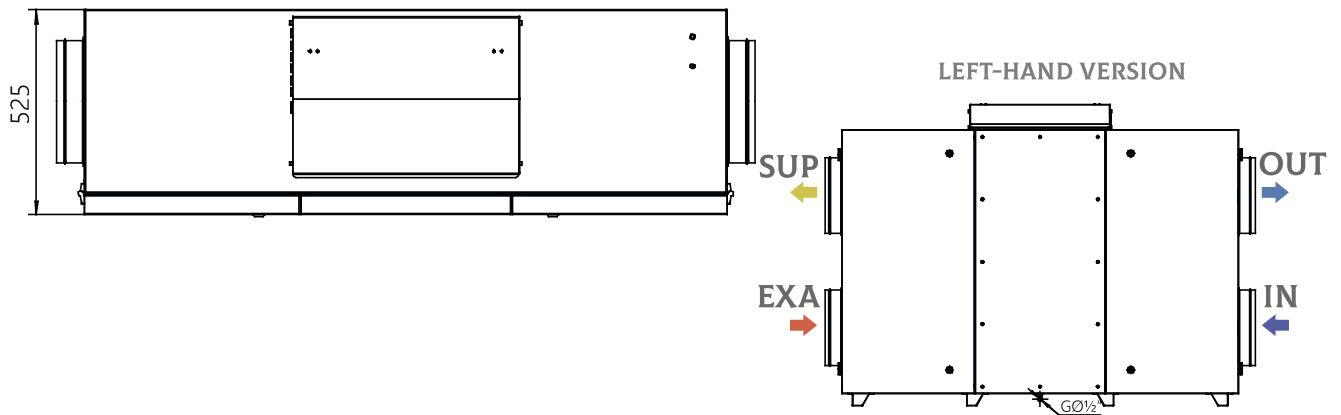
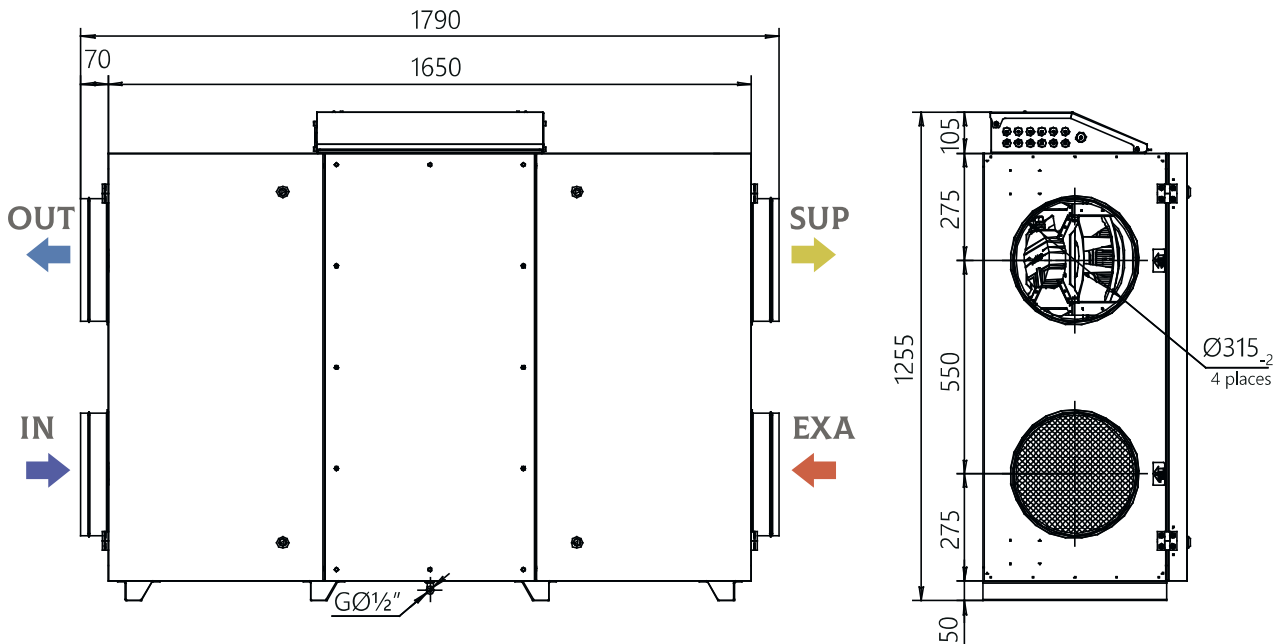

IN - outdoor air SUP - supply air EXA - exhaust air OUT - return air

Parameter	VALUE
Nominal air-flow rate*, m ³ /h	1300
External static pressure*, Pa	420
Maximum air flow rate (at static pressure 220 Pa), m ³ /h	1700
Supply voltage	~1 / 220 V / 50 Hz
Electric power of built-in electric heater, kW	5,0
Fan power (supply/exhaust), kW	0,5/0,5
Total electrical power of the AHU, kW	6
Filter (supply/exhaust)	M5/M5
Weight, kg, max	155

* The values are valid under normal conditions for both the supply and exhaust paths.





AEROSTART-EC-CF-1300	Sound power level, dB								Total sound pressure level, dB(A)**
	Octave band mid-frequency, Hz*								
	63	125	250	500	1000	2000	4000	8000	
Input	63	60	58	56	48	42	39	32	56
Output	69	70	73	68	63	60	58	54	70
Surrounding	67	65	55	43	43	45	46	43	54

* At nominal flow rate and maximum fan speed.

** Total sound pressure level (not to be confused with power) at a distance of 3 meters.

AERODYNAMIC CHARACTERISTICS

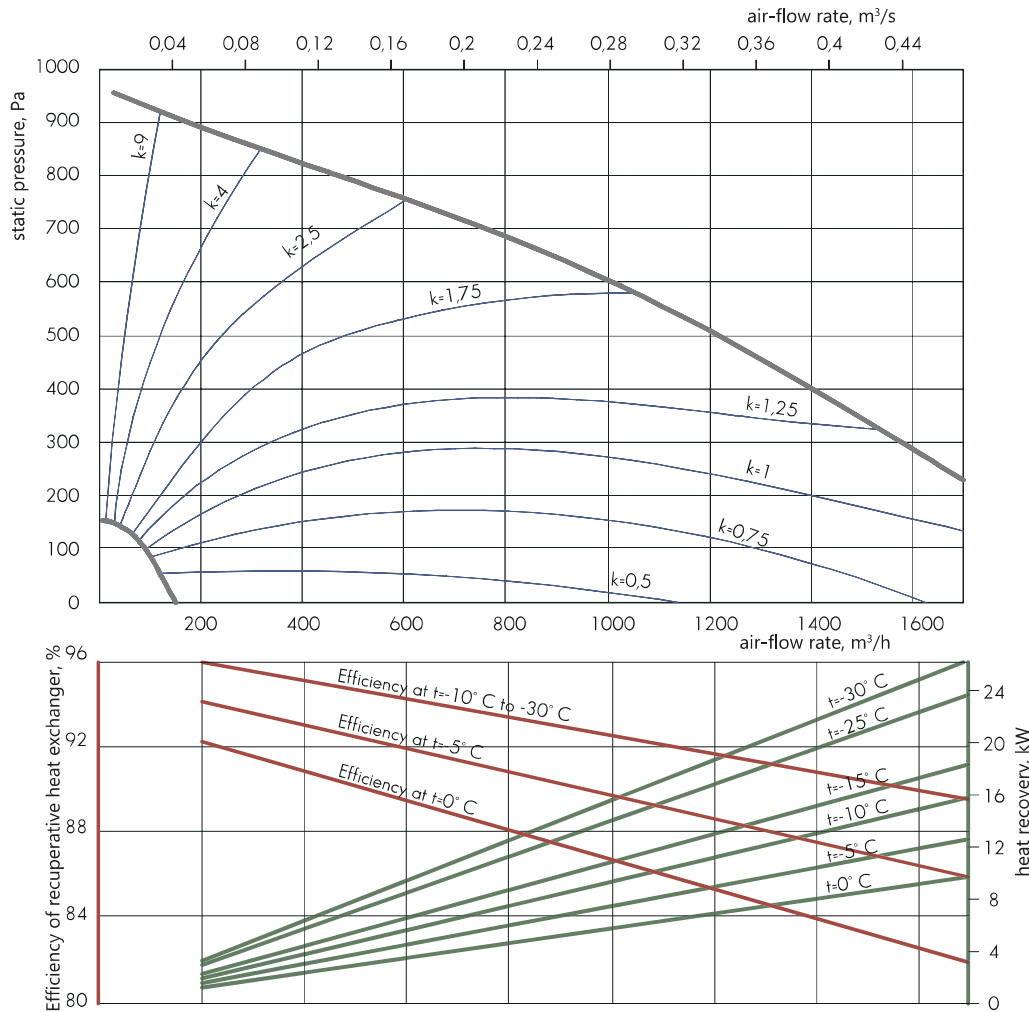

An example of using the aerodynamic characteristic and temperature efficiency graph is given above

TEMPERATURE EFFICIENCY

The temperature efficiency graph is shown at the same supply and exhaust air flow rates, and at the exhaust air temperature t = +20° C, relative humidity rh = 50%

- air valve
C-KVK-315
- insulated valve
C-GMK-C-50-25
- check valve
C-KOL-K-315
- single leaf damper
C-DKK-315
- duct silencer
C-GKK-315
- duct filter
C-FKK-315
- bag filter
C-FKK-315-BAG
- compact duct filter
C-FKK-L-315
- water/air-heater
C-KVN-K-315
- electric air heater
C-EVN-K-S3-315
- electric air heater
C-EVN-S3-50-25
- water/air-cooler
C-VKO-50-25
- Freon air cooler
C-FKO-50-25
- mounting clamp
C-MK-315
- adapter
AD-PSKK-500x250-315
- air intake grille
C-RVK-315
- exhaust grille
C-RVC-315
- supply and exhaust grille
C-RPVC-315
- non-adjustable grille
RKN-315
- water mixing unit
UWS

AIR HANDLING UNITS



AEROSTART-EC-CF-250-V

View F

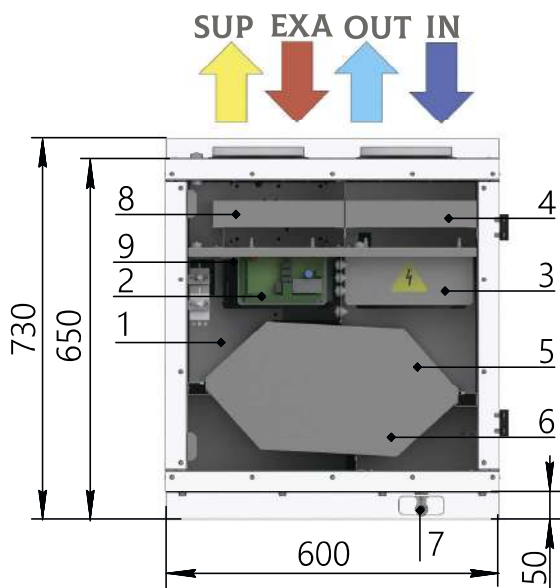

- 1. Electric air heater
- 2. Automation system unit
- 3. Supply air fan
- 4. Supply air filter
- 5. Bypass damper of recuperative heat exchanger
- 6. Counter-flow recuperative heat exchanger
- 7. Condensate drain
- 8. Exhaust air filter
- 9. Exhaust air fan

LEFT-HAND VERSION

View T

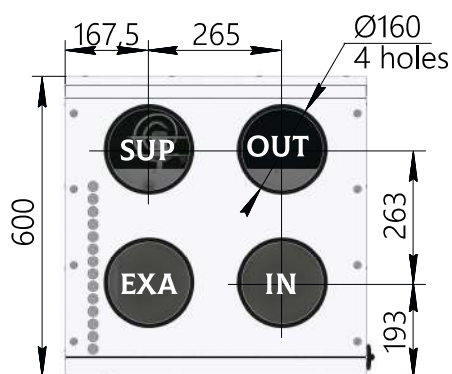

RIGHT-HAND VERSION

View T

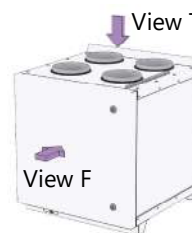

View F

View T

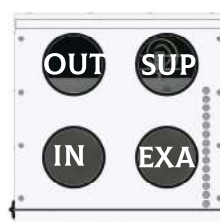

View F



IN - outdoor air SUP - supply air EXA - exhaust air OUT - return air

AIR HANDLING UNITS

32

Parameter	VALUE
Nominal air-flow rate*, m ³ /h	250
External static pressure*, Pa	320
Maximum air flow rate (at static pressure 220 Pa), m ³ /h	340
Supply voltage	~1 / 220 V / 50 Hz
Electric power of built-in electric heater, kW	0,9
Fan power (supply/exhaust), kW	0,08/0,08
Total electrical power of the AHU, kW	1,07
Filter (supply/exhaust)	M5/M5
Weight, kg, max	52

* The values are valid under normal conditions for both the supply and exhaust paths.

AEROSTART-EC-CF-250	Sound power level, dB								Total sound pressure level, dB(A)**
	Octave band mid-frequency, Hz*								
	63	125	250	500	1000	2000	4000	8000	
Input	49	48	48	50	43	38	32	26	49
Output	55	58	63	62	58	56	51	48	64
Surrounding	53	53	45	37	38	41	39	37	47

* At nominal flow rate and maximum fan speed.

** Total sound pressure level (not to be confused with power) at a distance of 3 meters.

AERODYNAMIC CHARACTERISTICS

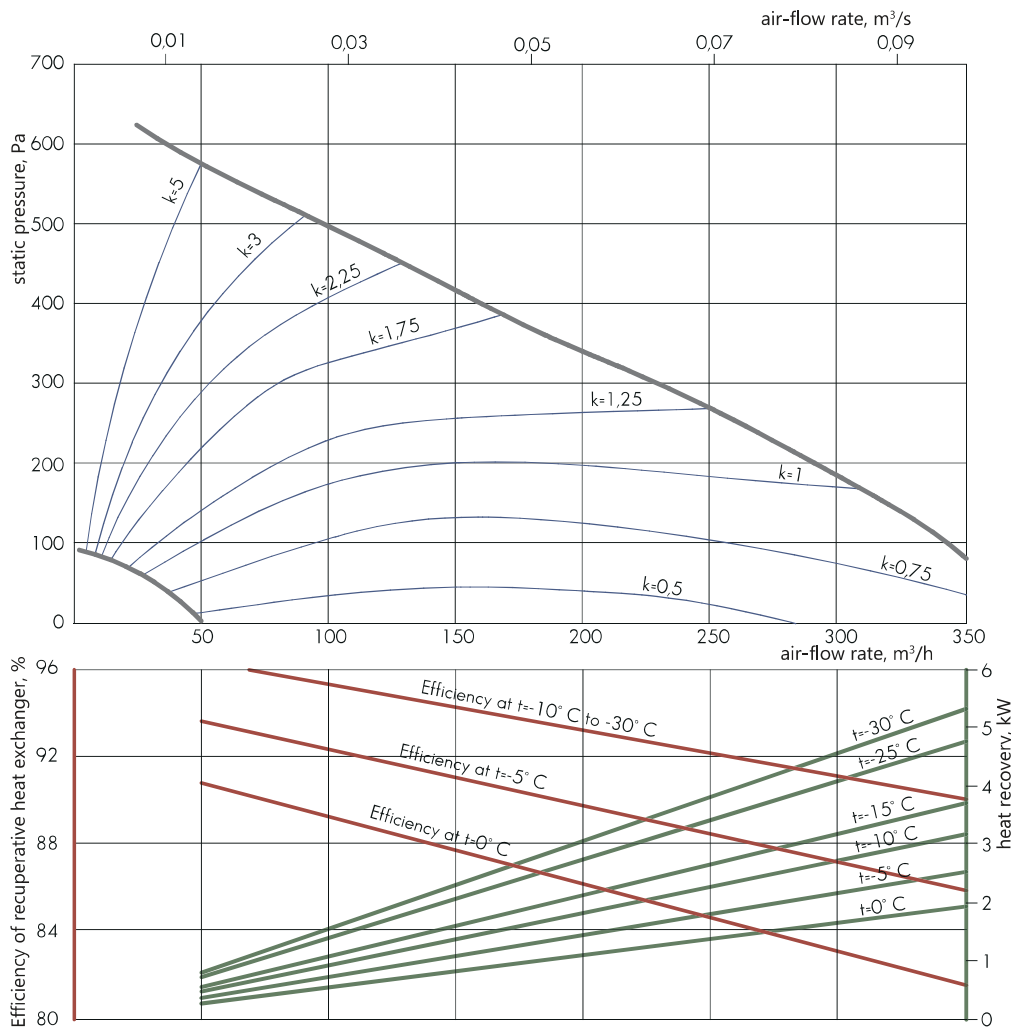

An example of using the aerodynamic characteristic and temperature efficiency graph is given above

TEMPERATURE EFFICIENCY

The temperature efficiency graph is shown at the same supply and exhaust air flow rates, and at the exhaust air temperature $t = +20^\circ\text{C}$, relative humidity $rh = 50\%$

- air valve
C-KVK-160
- insulated valve
C-GMK-C-40-20
- check valve
C-KOL-K-160
- single leaf damper
C-DKK-160
- duct silencer
C-GKK-160
- duct filter
C-FKK-160
- bag filter
C-FKK-160-BAG
- compact duct filter
C-FKK-L-160
- water/air-heater
C-KVN-K-160
- electric air heater
C-EVN-K-S3-160
- electric air heater
C-EVN-S3-40-20
- water/air-cooler
C-VKO-40-20
- Freon air cooler
C-FKO-40-20
- mounting clamp
C-MK-160
- adapter
AD-PSKK-400x200-160
- air intake grille
C-RVK-160
- exhaust grille
C-RVC-160
- supply and exhaust grille
C-RPVC-160
- non-adjustable grille
RKN-160
- water mixing unit
UWS

AIR HANDLING UNITS

AEROSTART-EC-CF-550-V

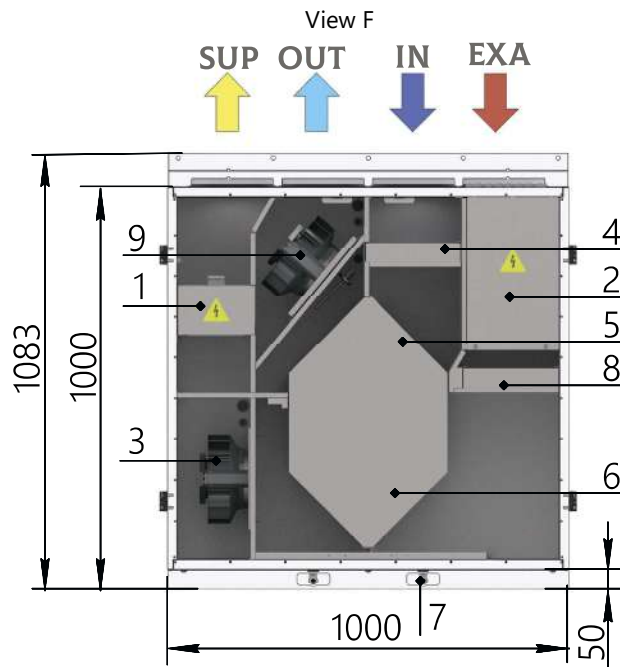

1. Electric air heater
2. Automation system unit
3. Supply air fan
4. Supply air filter
5. Bypass damper of recuperative heat exchanger
6. Counter-flow recuperative heat exchanger
7. Condensate drain
8. Exhaust air filter
9. Exhaust air fan

LEFT-HAND VERSION

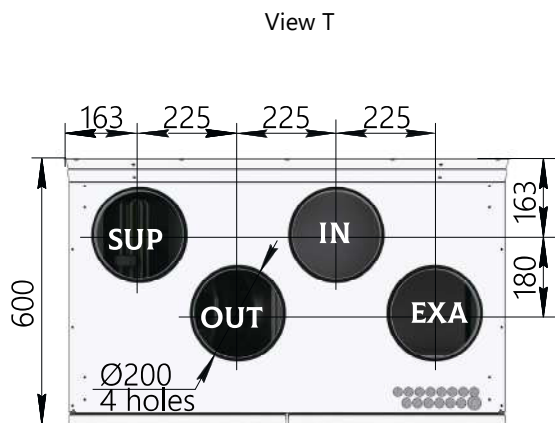

RIGHT-HAND VERSION

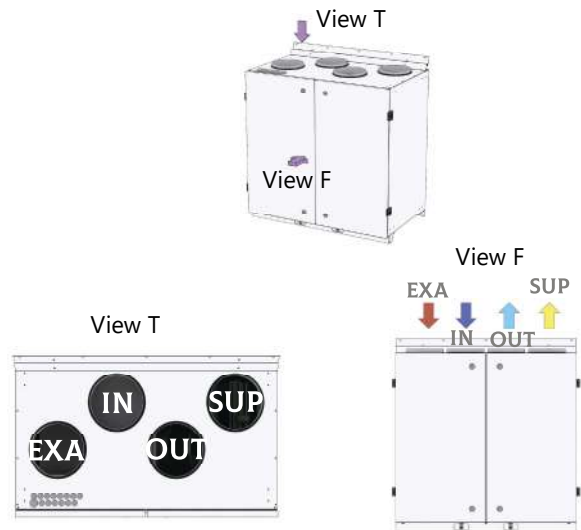

IN - outdoor air SUP - supply air EXA - exhaust air OUT - return air

Parameter	VALUE
Nominal air-flow rate*, m ³ /h	550
External static pressure*, Pa	260
Maximum air flow rate (at static pressure 220 Pa), m ³ /h	700
Supply voltage	~1 / 220 V / 50 Hz
Electric power of built-in electric heater, kW	2,0
Fan power (supply/exhaust), kW	0,17/0,17
Total electrical power of the AHU, kW	2,34
Filter (supply/exhaust)	M5/M5
Weight, kg, max	125

AIR HANDLING UNITS

* The values are valid under normal conditions for both the supply and exhaust paths.



AEROSTART-EC-CF-550	Sound power level, dB								Total sound pressure level, dB(A)**
	Octave band mid-frequency, Hz*								
	63	125	250	500	1000	2000	4000	8000	
Input	43	42	41	46	44	41	37	32	48
Output	49	52	56	58	59	59	56	54	65
Surrounding	47	47	38	33	39	44	44	43	50

* At nominal flow rate and maximum fan speed.

** Total sound pressure level (not to be confused with power) at a distance of 3 meters.

AERODYNAMIC CHARACTERISTICS

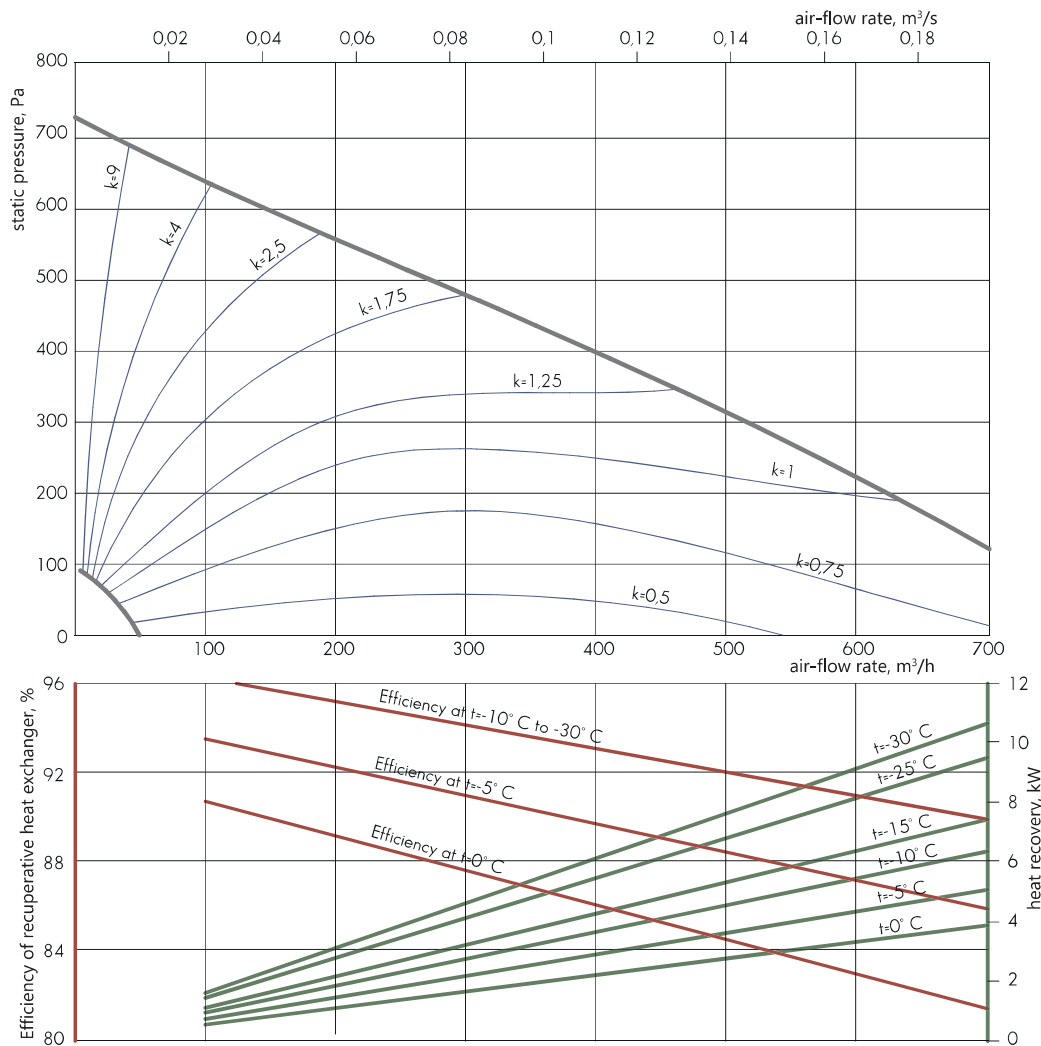

An example of using the aerodynamic characteristic and temperature efficiency graph is given above

TEMPERATURE EFFICIENCY

The temperature efficiency graph is shown at the same supply and exhaust air flow rates, and at the exhaust air temperature $t = +20^\circ\text{C}$, relative humidity $rh = 50\%$

- air valve
C-KVK-200
- insulated valve
C-GMK-C-40-20
- check valve
C-KOL-K-200
- single leaf damper
C-DKK-200
- duct silencer
C-GKK-200
- duct filter
C-FKK-200
- bag filter
C-FKK-200-BAG
- compact duct filter
C-FKK-L-200
- water/air-heater
C-KVN-K-200
- electric air heater
C-EVN-K-S3-200
- electric air heater
C-EVN-S3-40-20
- water/air-cooler
C-VKO-40-20
- Freon air cooler
C-FKO-40-20
- mounting clamp
C-MK-200
- adapter
AD-PSKK-400x200-200
- air intake grille
C-RVK-200
- exhaust grille
C-RVC-200
- supply and exhaust grille
C-RPVC-200
- non-adjustable grille
RKN-200
- water mixing unit
UWS

AIR HANDLING UNITS



AEROSTART-EC-CF-900-V

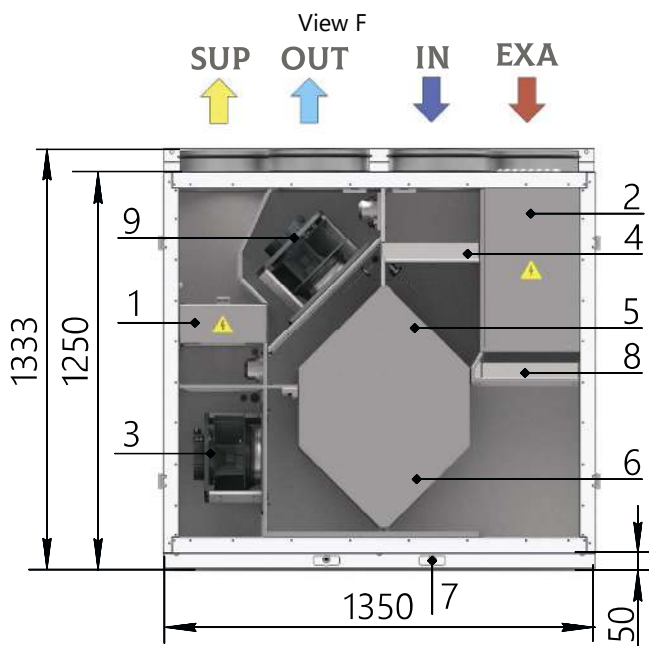

- 1. Electric air heater
- 2. Automation system unit
- 3. Supply air fan
- 4. Supply air filter
- 5. Bypass damper of recuperative heat exchanger
- 6. Counter-flow recuperative heat exchanger
- 7. Condensate drain
- 8. Exhaust air filter
- 9. Exhaust air fan

LEFT-HAND VERSION

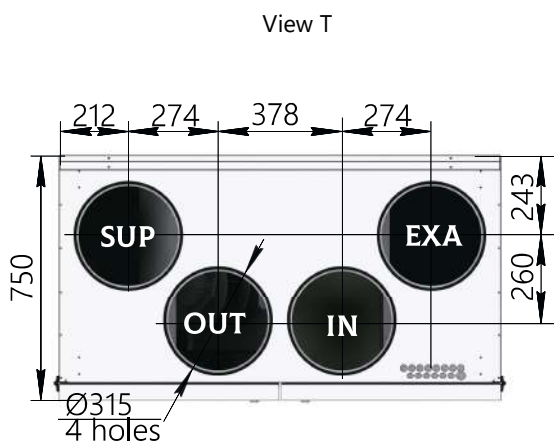

RIGHT-HAND VERSION

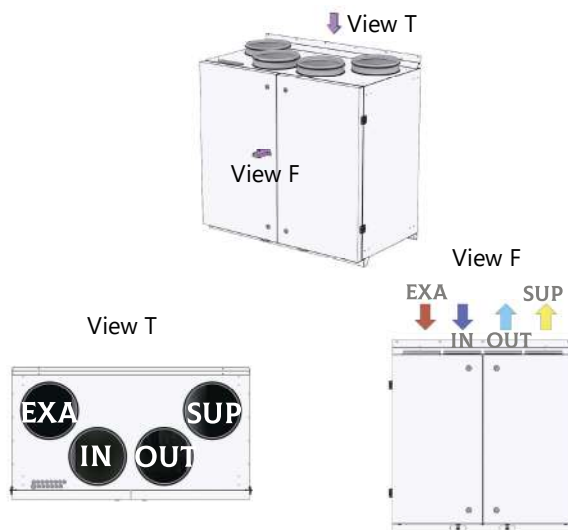

IN - outdoor air SUP - supply air EXA - exhaust air OUT - return air

Parameter	VALUE
Nominal air-flow rate*, m ³ /h	900
External static pressure*, Pa	250
Maximum air flow rate (at static pressure 220 Pa), m ³ /h	1050
Supply voltage	~1 / 220 V / 50 Hz
Electric power of built-in electric heater, kW	3,3
Fan power (supply/exhaust), kW	0,26/0,26
Total electrical power of the AHU, kW	3,82
Filter (supply/exhaust)	M5/M5
Weight, kg, max	175

* The values are valid under normal conditions for both the supply and exhaust paths.

AEROSTART-EC-CF-900	Sound power level, dB								Total sound pressure level, dB(A)**
	Octave band mid-frequency, Hz*								
	63	125	250	500	1000	2000	4000	8000	
Input	56	54	47	49	46	40	35	27	50
Output	62	64	62	61	61	58	54	49	65
Surrounding	60	59	44	36	41	43	42	38	50

* At nominal flow rate and maximum fan speed.

** Total sound pressure level (not to be confused with power) at a distance of 3 meters.

AERODYNAMIC CHARACTERISTICS

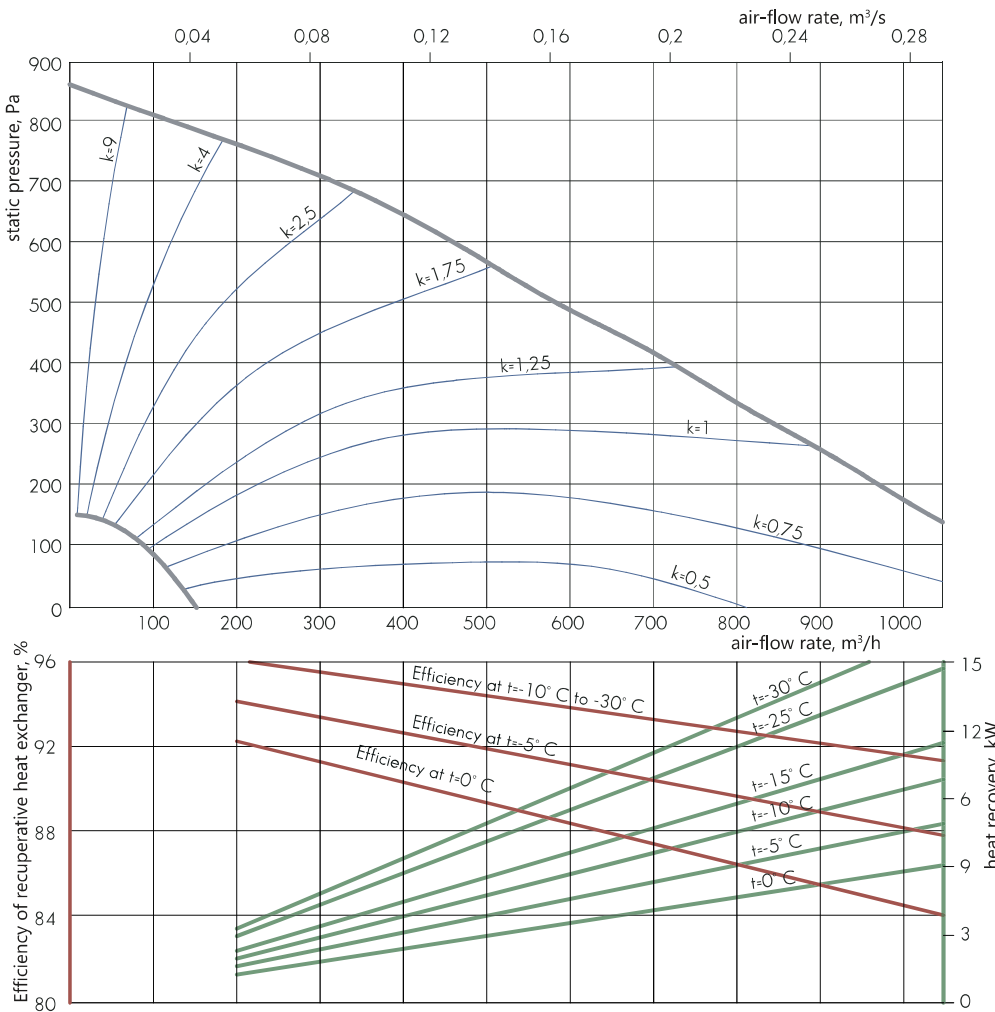

An example of using the aerodynamic characteristic and temperature efficiency graph is given above

TEMPERATURE EFFICIENCY

The temperature efficiency graph is shown at the same supply and exhaust air flow rates, and at the exhaust air temperature $t = +20^\circ\text{C}$, relative humidity $rh = 50\%$

air valve
C-KVK-315

insulated valve
C-GMK-C-40-20

check valve
C-KOL-K-315

single leaf damper
C-DKK-315

duct silencer
C-GKK-315

duct filter
C-FKK-315

bag filter
C-FKK-315-BAG

compact duct filter
C-FKK-L-315

water/air-heater
C-KVN-K-315

electric air heater
C-EVN-K-S3-315

electric air heater
C-EVN-S3-40-20

water/air-cooler
C-VKO-40-20

Freon air cooler
C-FKO-40-20

mounting clamp
C-MK-315

adapter
AD-PSKK-400x200-315

air intake grille
C-RVK-315

exhaust grille
C-RVC-315

supply and exhaust grille
C-RPVC-315

non-adjustable grille
RKN-315

water mixing unit
UWS

AEROSTART-EC-CF-1300-V

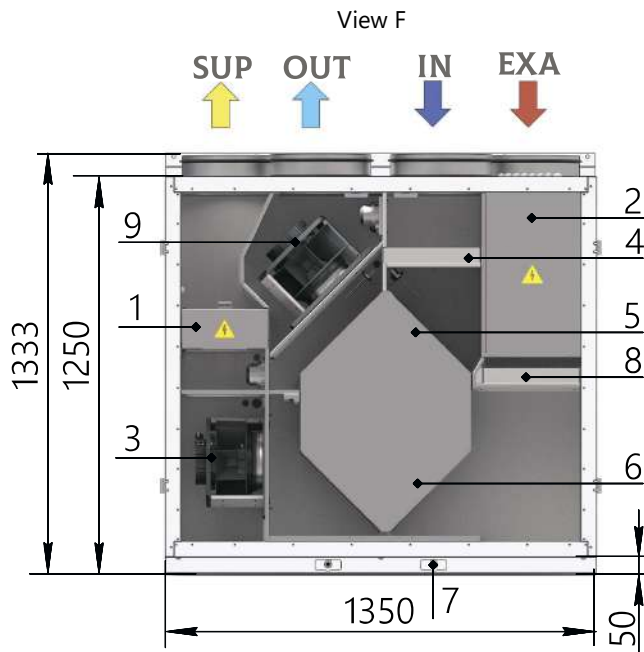

1. Electric air heater
2. Automation system unit
3. Supply air fan
4. Supply air filter
5. Bypass damper of recuperative heat exchanger
6. Counter-flow recuperative heat exchanger
7. Condensate drain
8. Exhaust air filter
9. Exhaust air fan

LEFT-HAND VERSION

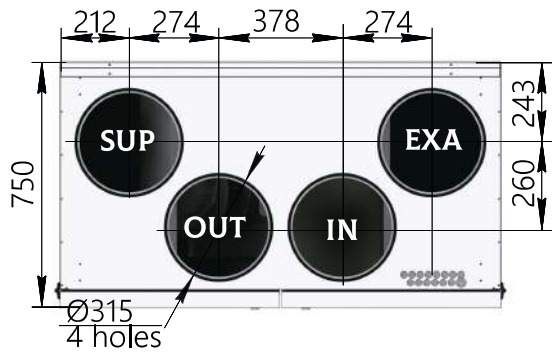

RIGHT-HAND VERSION

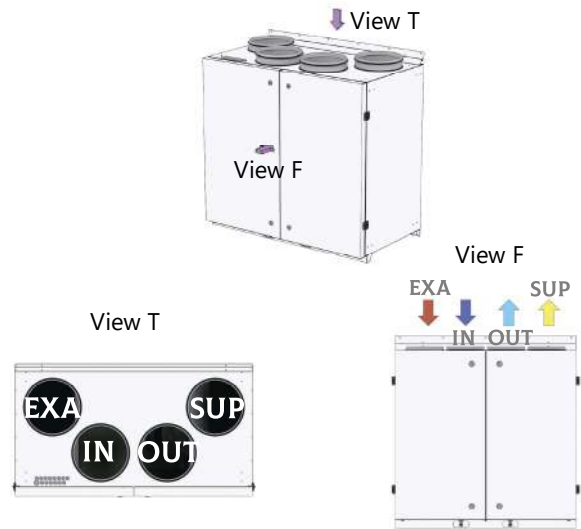

IN - outdoor air SUP - supply air EXA - exhaust air OUT - return air

Parameter	VALUE
Nominal air-flow rate*, m ³ /h	1300
External static pressure*, Pa	370
Maximum air flow rate (at static pressure 220 Pa), m ³ /h	1700
Supply voltage	~1 / 220 V / 50 Hz
Electric power of built-in electric heater, kW	5,0
Fan power (supply/exhaust), kW	0,5/0,5
Total electrical power of the AHU, kW	6
Filter (supply/exhaust)	M5/M5
Weight, kg, max	182

* The values are valid under normal conditions for both the supply and exhaust paths.



AEROSTART-EC-CF-1300	Sound power level, dB								Total sound pressure level, dB(A)**
	Octave band mid-frequency, Hz*								
	63	125	250	500	1000	2000	4000	8000	
Input	63	60	58	56	48	42	39	32	56
Output	69	70	73	68	63	60	58	54	70
Surrounding	67	65	55	43	43	45	46	43	54

* At nominal flow rate and maximum fan speed.

** Total sound pressure level (not to be confused with power) at a distance of 3 meters.

AERODYNAMIC CHARACTERISTICS

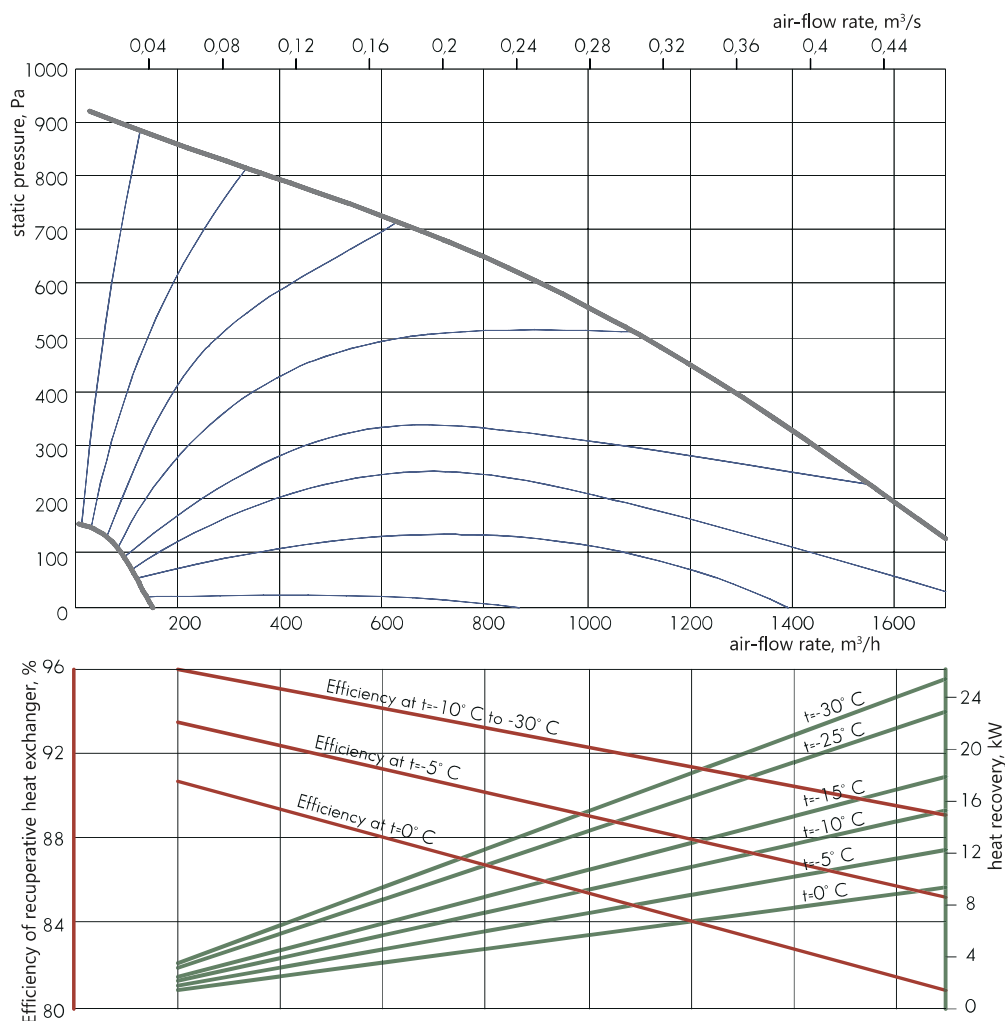

An example of using the aerodynamic characteristic and temperature efficiency graph is given above

TEMPERATURE EFFICIENCY

The temperature efficiency graph is shown at the same supply and exhaust air flow rates, and at the exhaust air temperature $t = +20^{\circ}\text{C}$, relative humidity $rh = 50\%$

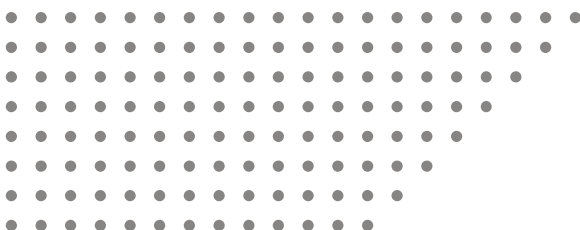

- air valve
C-KVK-315
- insulated valve
C-GMK-C-50-25
- check valve
C-KOL-K-315
- single leaf damper
C-DKK-315
- duct silencer
C-GKK-315
- duct filter
C-FKK-315
- bag filter
C-FKK-315-BAG
- compact duct filter
C-FKK-L-315
- water/air-heater
C-KVN-K-315
- electric air heater
C-EVN-K-S3-315
- electric air heater
C-EVN-S3-50-25
- water/air-cooler
C-VKO-50-25
- Freon air cooler
C-FKO-50-25
- mounting clamp
C-MK-315
- adapter
AD-PSKK-500x250-315
- air intake grille
C-RVK-315
- exhaust grille
C-RVC-315
- supply and exhaust grille
C-RPVC-315
- non-adjustable grille
RKN-315
- water mixing unit
UWS



AEROSTART-EC-CF-2000-V

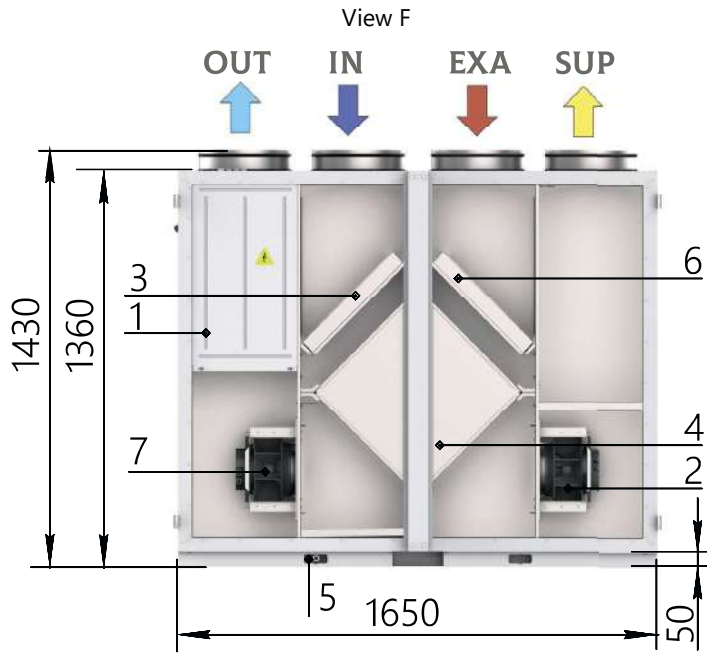

1. Automation system unit
2. Supply air fan
3. Supply air filter
4. Counter-flow recuperative heat exchanger
5. Condensate drain
6. Exhaust air filter
7. Exhaust air fan

RIGHT-HAND VERSION

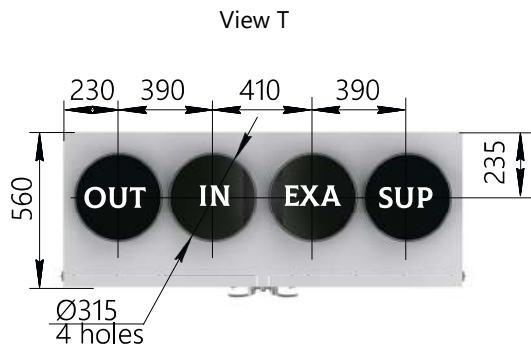

LEFT-HAND VERSION



IN - outdoor air SUP - supply air EXA - exhaust air OUT - return air

AIR HANDLING UNITS

Parameter	VALUE
Nominal air-flow rate*, m ³ /h	2 000
External static pressure*, Pa	240
Maximum air flow rate (at static pressure 240 Pa), m ³ /h	2 000
Supply voltage	~1 / 220 V / 50 Hz
Fan power (supply/exhaust), kW	0,5/0,5
Total electrical power of the AHU, kW	1
Filter (supply/exhaust)	M5/M5
Weight, kg, max	185

* The values are valid under normal conditions for both the supply and exhaust paths.



AEROSTART-EC-CF-2000	Sound power level, dB								Total sound pressure level, dB(A)**
	Octave band mid-frequency, Hz*								
	63	125	250	500	1000	2000	4000	8000	
Input	63	60	58	56	48	42	39	32	56
Output	69	70	73	68	63	60	58	54	70
Surrounding	67	65	55	43	43	45	46	43	54

* At nominal flow rate and maximum fan speed.

** Total sound pressure level (not to be confused with power) at a distance of 3 meters.

AERODYNAMIC CHARACTERISTICS

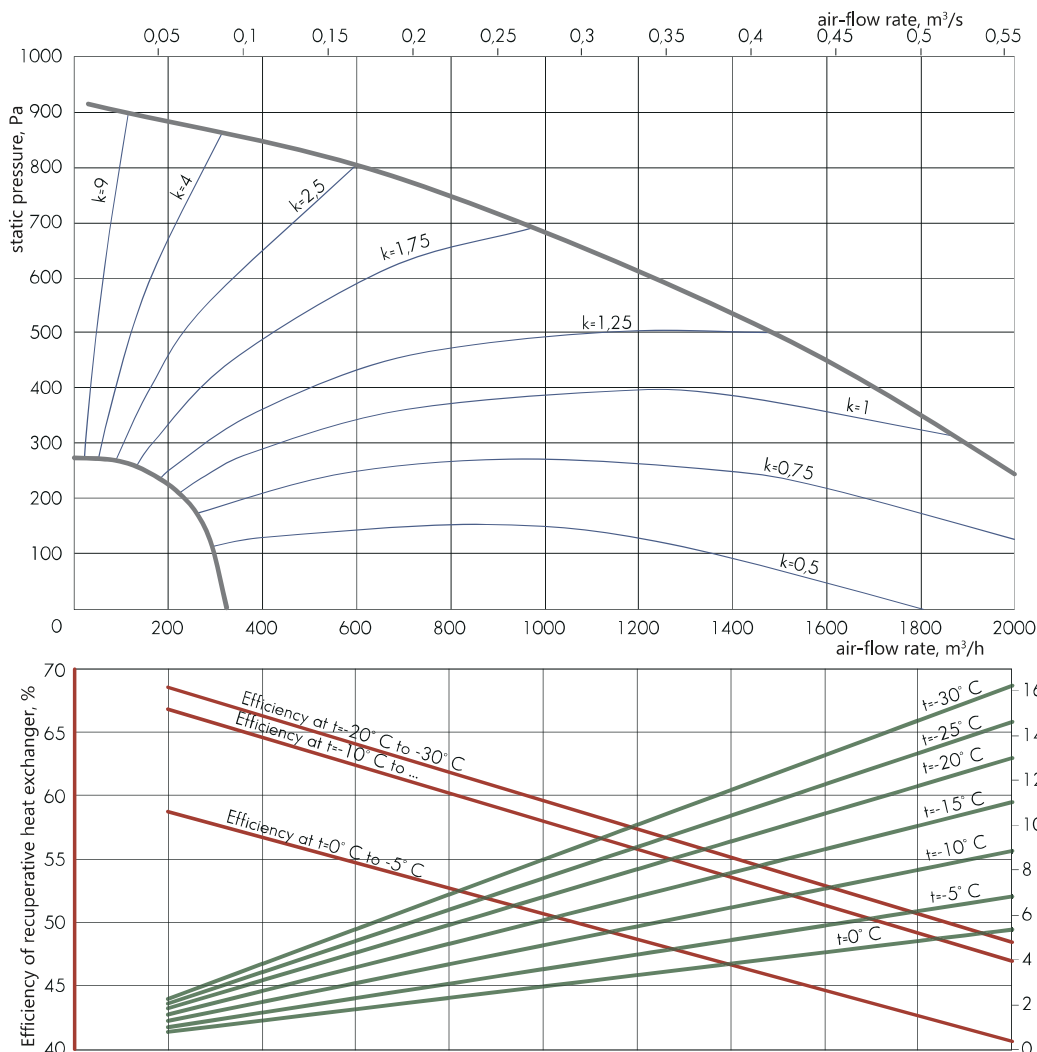

An example of using the aerodynamic characteristic and temperature efficiency graph is given above

TEMPERATURE EFFICIENCY

The temperature efficiency graph is shown at the same supply and exhaust air flow rates, and at the exhaust air temperature $t = +20^\circ\text{C}$, relative humidity $rh = 50\%$

- air valve
C-KVK-315
- insulated valve
C-GMK-C-50-30
- check valve
C-KOL-K-315
- single leaf damper
C-DKK-315
- duct silencer
C-GKK-315
- duct filter
C-FKK-315
- bag filter
C-FKK-315-BAG
- compact duct filter
C-FKK-L-315
- water/air-heater
C-KVN-50-30
- electric air heater
C-EVN-K-S3-315
- electric air heater
C-EVN-S3-50-30
- water/air-cooler
C-VKO-50-30
- Freon air cooler
C-FKO-50-30
- mounting clamp
C-MK-315
- adapter
AD-PSKK-500x300-315
- air intake grille
C-RVK-315
- exhaust grille
C-RVC-315
- supply and exhaust grille
C-RPVC-315
- non-adjustable grille
RKN-315
- water mixing unit
UWS

AIR HANDLING UNITS



AEROSTART-EC-CF-3000-V

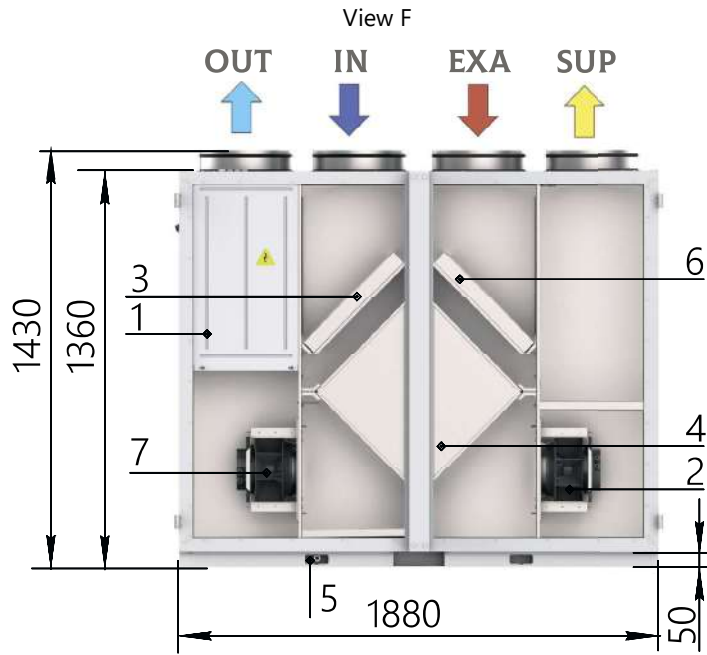

1. Automation system unit
2. Supply air fan
3. Supply air filter
4. Counter-flow recuperative heat exchanger
5. Condensate drain
6. Exhaust air filter
7. Exhaust air fan

RIGHT-HAND VERSION

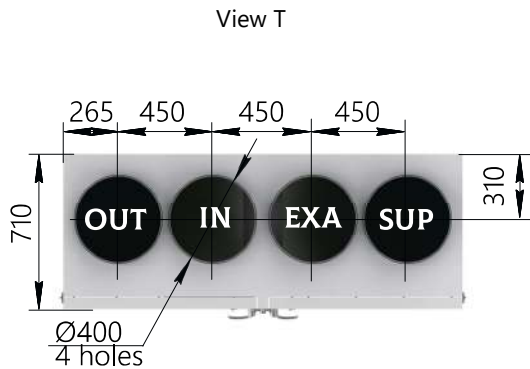

LEFT-HAND VERSION



View T

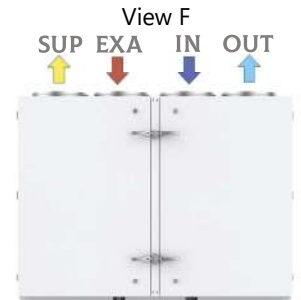

IN - outdoor air SUP - supply air EXA - exhaust air OUT - return air

AIR HANDLING UNITS

Parameter	VALUE
Nominal air-flow rate*, m ³ /h	3 000
External static pressure*, Pa	275
Maximum air flow rate (at static pressure 240 Pa), m ³ /h	3 100
Supply voltage	~3 / 380 V / 50 Hz
Fan power (supply/exhaust), kW	1/1
Total electrical power of the AHU, kW	2
Filter (supply/exhaust)	M5/M5
Weight, kg, max	225

* The values are valid under normal conditions for both the supply and exhaust paths.



AEROSTART-EC-CF-3000	Sound power level, dB								Total sound pressure level, dB(A)**
	Octave band mid-frequency, Hz*								
	63	125	250	500	1000	2000	4000	8000	
Input	60	55	68	65	62	61	59	54	68
Output	63	57	70	68	70	68	64	59	74
Surrounding	61	52	52	43	50	53	52	48	58

* At nominal flow rate and maximum fan speed.

** Total sound pressure level (not to be confused with power) at a distance of 3 meters.

AERODYNAMIC CHARACTERISTICS

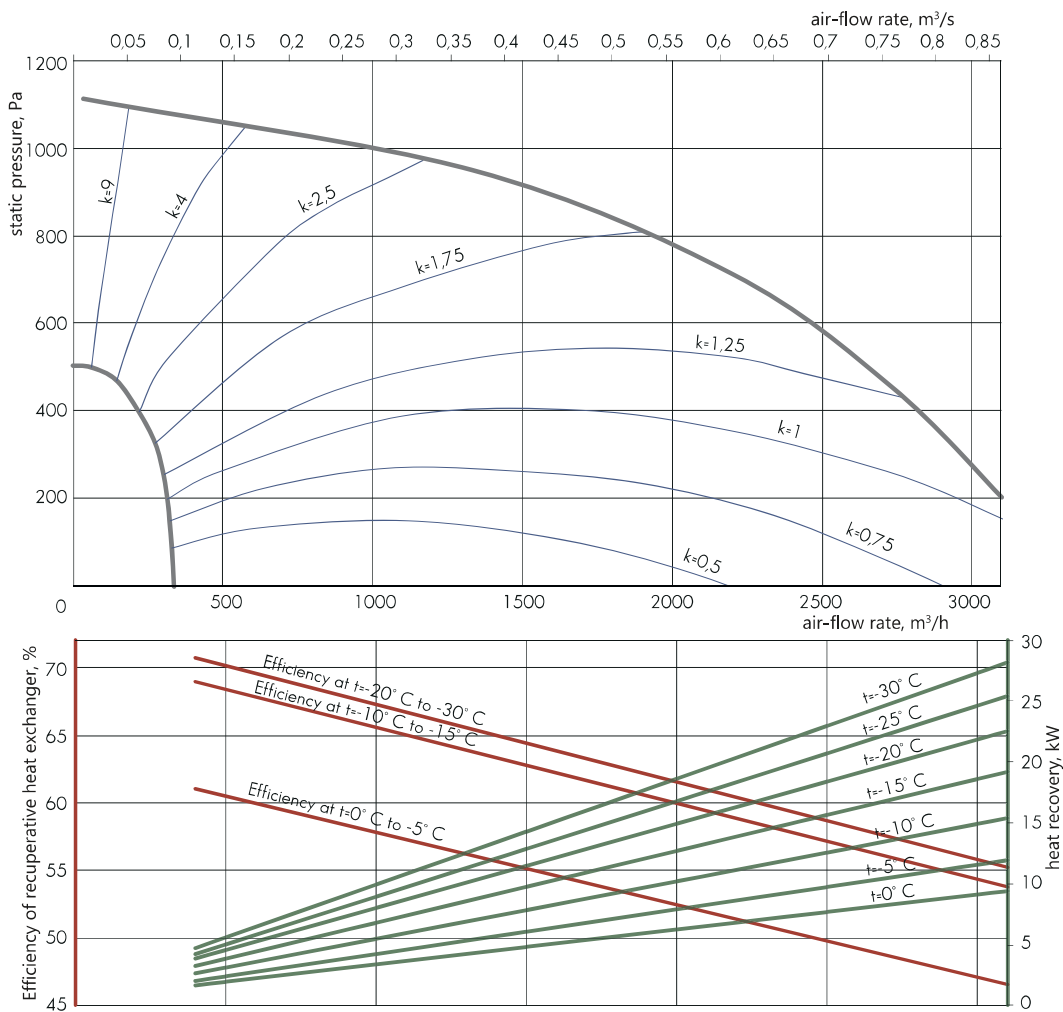

An example of using the aerodynamic characteristic and temperature efficiency graph is given above

TEMPERATURE EFFICIENCY

The temperature efficiency graph is shown at the same supply and exhaust air flow rates, and at the exhaust air temperature t = +20° C, relative humidity rh = 50%

- air valve
C-KVK-400
- insulated valve
C-GMK-C-60-35
- check valve
C-KOL-K-400
- single leaf damper
C-DKK-400
- duct silencer
C-GKK-400
- duct filter
C-FKK-400
- bag filter
C-FKK-400-BAG
- compact duct filter
C-FKK-L-400
- water/air-heater
C-KVN-60-35
- electric air heater
C-EVN-K-S3-400
- electric air heater
C-EVN-S3-60-35
- water/air-cooler
C-VKO-60-35
- Freon air cooler
C-FKO-60-35
- mounting clamp
C-MK-400
- adapter
AD-PSKK-600x350-400
- air intake grille
C-RVK-400
- exhaust grille
C-RVC-400
- supply and exhaust grille
C-RPVC-400
- non-adjustable grille
RKN-400
- water mixing unit
UWS



AEROSTART-EC-CF-4000-V

View F

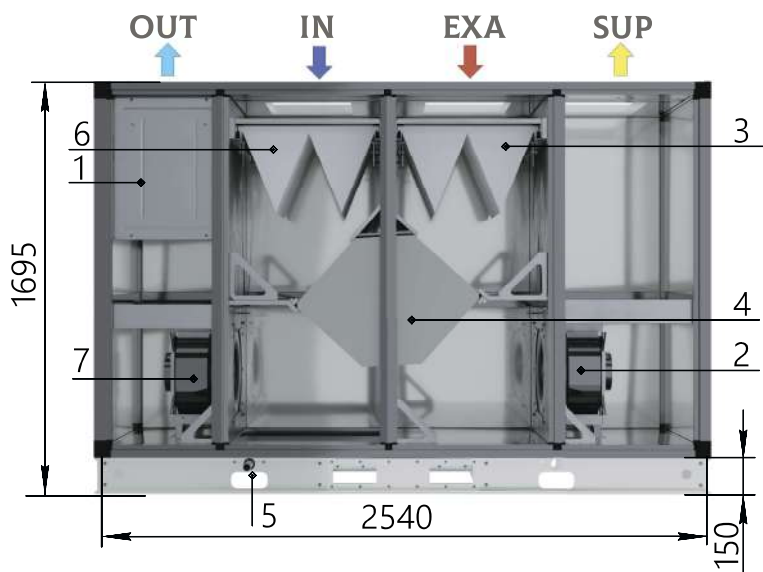

- 1. Automation system unit
- 2. Supply air fan
- 3. Supply air filter
- 4. Recuperative heat exchanger
- 5. Condensate drain
- 6. Exhaust air filter
- 7. Exhaust air fan

RIGHT-HAND VERSION
View T

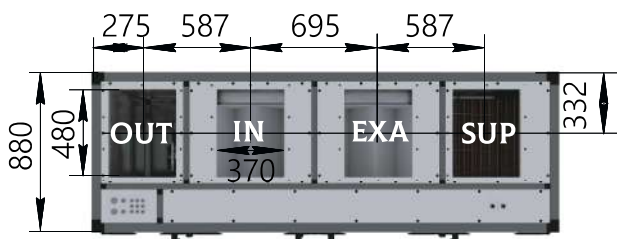

LEFT-HAND VERSION

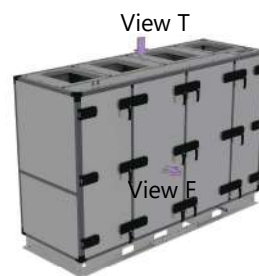

View T



View F

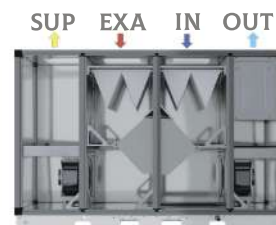

IN - outdoor air SUP - supply air EXA - exhaust air OUT - return air

AIR HANDLING UNITS

44

Parameter	VALUE
Nominal air-flow rate*, m ³ /h	4 000
External static pressure*, Pa	360
Maximum air flow rate (at static pressure 240 Pa), m ³ /h	4 200
Supply voltage	~3 / 380 V / 50 Hz
Fan power (supply/exhaust), kW	1,5/1,5
Total electrical power of the AHU, kW	3
Filter (supply/exhaust)	M5/M5
Weight, kg, max	484

* The values are valid under normal conditions for both the supply and exhaust paths.

AEROSTART-EC-CF-4000	Sound power level, dB								Total sound pressure level, dB(A)**
	Octave band mid-frequency, Hz*								
	63	125	250	500	1000	2000	4000	8000	
Input	49	48	55	57	52	52	48	45	59
Output	51	50	59	59	63	61	56	52	67
Surrounding	52	48	44	37	46	49	47	44	54

* At nominal flow rate and maximum fan speed.

** Total sound pressure level (not to be confused with power) at a distance of 3 meters.

AERODYNAMIC CHARACTERISTICS

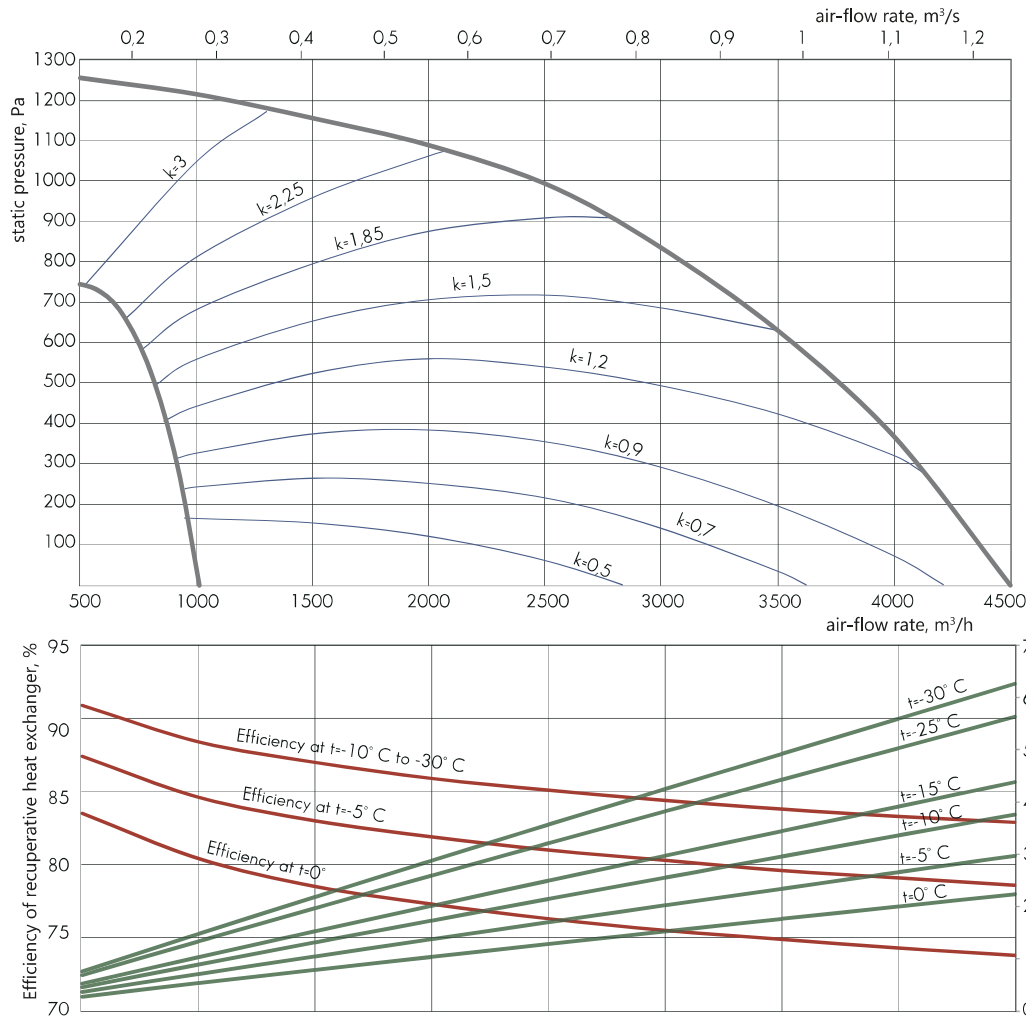

An example of using the aerodynamic characteristic and temperature efficiency graph is given above

TEMPERATURE EFFICIENCY

The temperature efficiency graph is shown at the same supply and exhaust air flow rates, and at the exhaust air temperature $t = +20^\circ\text{C}$, relative humidity $rh = 50\%$

universal air valve

C-REG-80-50

air valve

C-GMK-P-80-50

insulated valve

C-GMK-C-80-50

check valve

C-KOL-80-50

duct silencer

C-GKP-80-50

duct filter

C-FKP-80-50

water/air-heater

C-KVN-80-50

electric air heater

C-EVN-80-50

water/air-cooler

C-VKO-80-50

Freon air cooler

C-FKO-80-50

duct silencer

C-GKD-80-50

adapter

AD-PDK-500x400-800x500

non-adjustable grille

C-RKO-80-50

non-adjustable grille

C-RKA-80-50

water mixing unit

UWS

AEROSTART-EC-CF-5000-V

View F

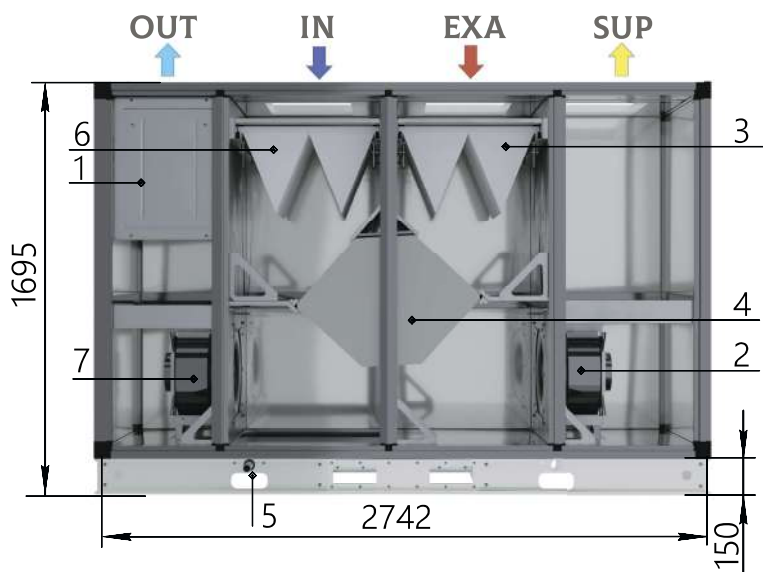

1. Automation system unit
2. Supply air fan
3. Supply air filter
4. Counter-flow recuperative heat exchanger
5. Condensate drain
6. Exhaust air filter
7. Exhaust air fan

RIGHT-HAND VERSION

View T

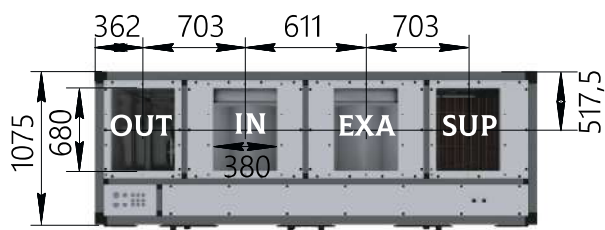

LEFT-HAND VERSION

View T

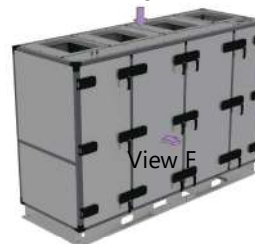

View F

View T



View F

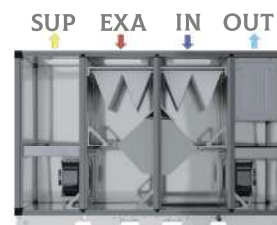

IN - outdoor air SUP - supply air EXA - exhaust air OUT - return air

AIR HANDLING UNITS

46

Parameter	VALUE
Nominal air-flow rate*, m ³ /h	5 000
External static pressure*, Pa	580
Maximum air flow rate (at static pressure 240 Pa), m ³ /h	5 400
Supply voltage	~3 / 380 V / 50 Hz
Fan power (supply/exhaust), kW	2,5/2,5
Total electrical power of the AHU, kW	5
Filter (supply/exhaust)	M5/M5
Weight, kg, max	614

* The values are valid under normal conditions for both the supply and exhaust paths.

AEROSTART-EC-CF-5000	Sound power level, dB								Total sound pressure level, dB(A)**
	Octave band mid-frequency, Hz*								
	63	125	250	500	1000	2000	4000	8000	
Input	56	50	56	62	57	57	54	50	64
Output	56	53	60	65	68	66	61	58	72
Surrounding	57	51	45	43	51	54	52	50	59

* At nominal flow rate and maximum fan speed.

** Total sound pressure level (not to be confused with power) at a distance of 3 meters.

AERODYNAMIC CHARACTERISTICS

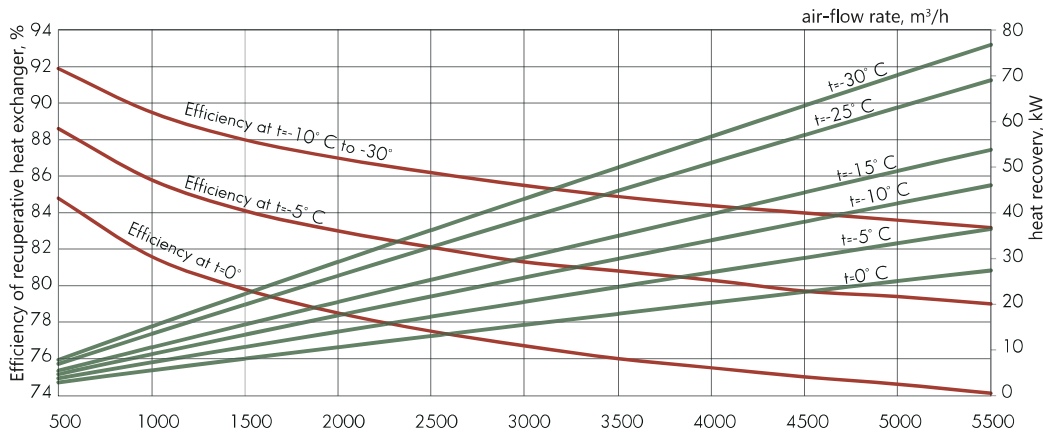
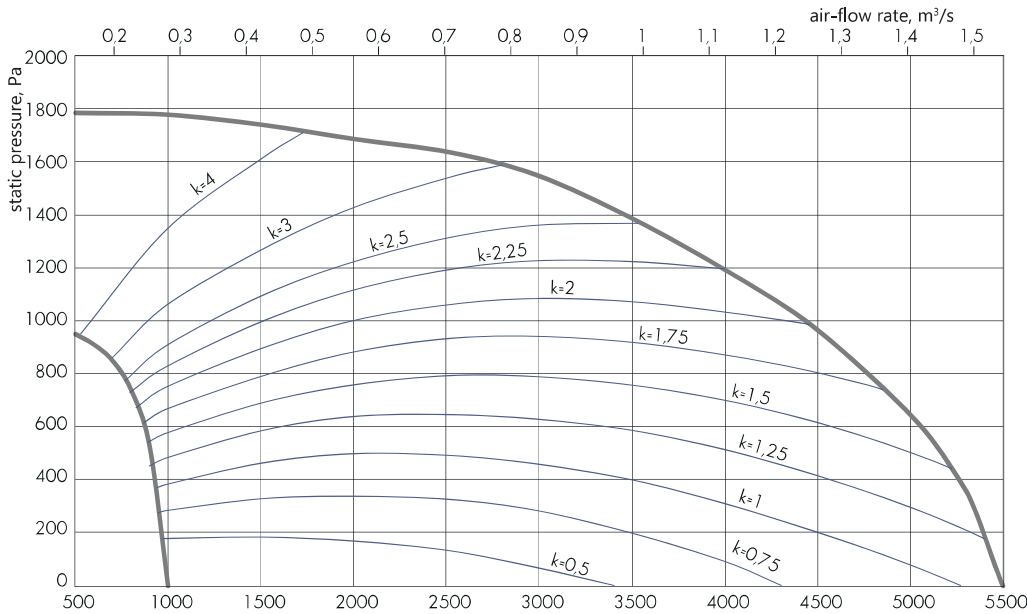

An example of using the aerodynamic characteristic and temperature efficiency graph is given above

TEMPERATURE EFFICIENCY

The temperature efficiency graph is shown at the same supply and exhaust air flow rates, and at the exhaust air temperature $t = +20^\circ\text{C}$, relative humidity $rh = 50\%$

universal air valve

C-REG-80-50

air valve

C-GMK-P-80-50

insulated valve

C-GMK-C-80-50

check valve

C-KOL-80-50

duct silencer

C-GKP-80-50

duct filter

C-FKP-80-50

water/air-heater

C-KVN-80-50

electric air heater

C-EVN-80-50

water/air-cooler

C-VKO-80-50

Freon air cooler

C-FKO-80-50

duct silencer

C-GKD-80-50

adapter

AD-PDK-700x400-800x500

non-adjustable grille

C-RKO-80-50

non-adjustable grille

C-RKA-80-50

water mixing unit

UWS

AUTOMATIC CONTROL SYSTEM



The automatic control system is used for power supply and automated control of AEROSTART-EC air handling units. Intelligent software allows for the implementation of a wide range of functions of the unit and provides reliable control and monitoring algorithms.

Structurally, the automation system is a control board. All monitoring and control devices and instruments located inside the unit are already connected to the control board.

In 900, 1300, 2000, 3000, 4000 and 5000 ceiling-suspended air handling units, the control board is located outside and hung on the side wall of the unit.

AEROSTART-EC air handling units are manufactured on the plug & play principle, which, combined with built-in intelligent automation, reduces installation costs, and also facilitates the start-up of units and their commissioning.

The units are controlled by a remote control, which is always included in the delivery package. The control panel features a modern design and a touch screen, which allows it to be conveniently integrated into the interior of any room. A 16 m long switching cable is supplied with the control panel.

AHU can also be controlled via the ModBus RS485 protocol. The built-in automation system ensures not only optimal operation control, but also safe operation of the AHU. The units can operate both in the constant air volume (CAV) mode and in the variable air volume (VAV) mode, which allows for the implementation of various ventilation system control tasks.

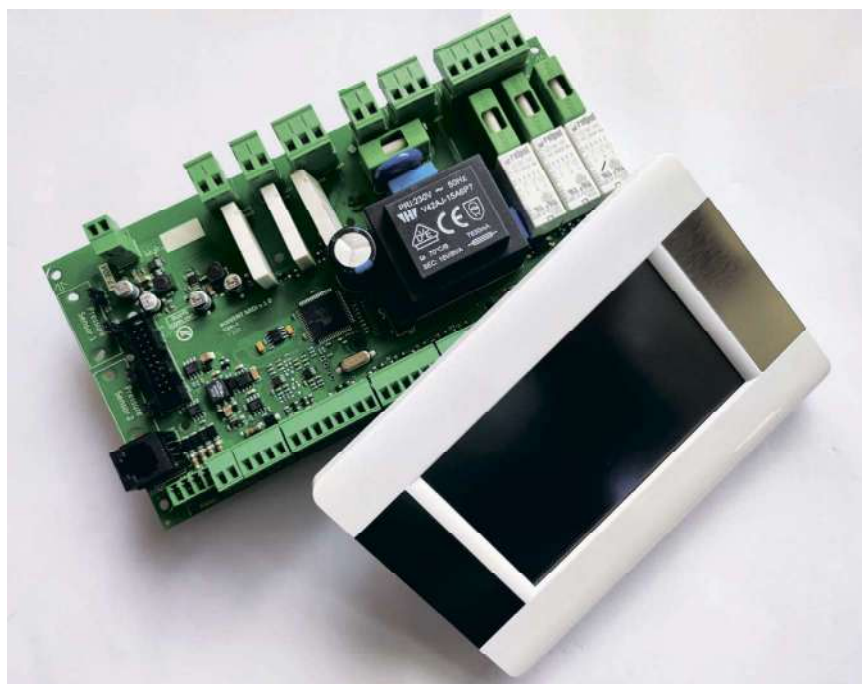

MAIN FUNCTIONS

Air temperature control	The unit automatically maintains the supply air temperature according to the set value. Monitoring is carried out by the air temperature sensor inside the duct and the indoor air temperature sensor (built into the control panel).
Air valve control	Air valves are not included in the AEROSTART-EC-CF units and are classified as accessories. However, the integrated automation system of units provides for controlling the operation of electric drives 220 V of air intake valves, both with and without a return spring. It provides connection and power supply of perimeter heating of air valves, which are used in regions with low outdoor temperatures.
Individual supply and exhaust air flow rate *	The integrated automation system of the units allows controlling the speed of the supply and exhaust fans independently of each other.
Additional heater control	In some cases, the built-in electric heater may not be sufficient to heat the supply air to the required temperature. This requires the installation of an additional heater. The automation of the AEROSTART-EC-CF units allows, as standard, the connection and control of an additional external heater – both water and electric.
Protection of recuperative heat exchanger from icing	The recuperative heat exchanger can be protected from icing by controlling the bypass valve (for units with a built-in bypass valve) or organizing preheating of the outdoor air. The integrated automation system can control the power of the external electric preheater C-EVN-K-S2 depending on the system configuration. Power supply and protection are provided by the customer
External cooler control	The unit is capable of monitoring and maintaining the air temperature in the premise by controlling the operation of the liquid cooler (0-10 V signal).
Scheduled operation	It is possible to program both by daily hours and by days of the week.
AHU control using the control panel	All units are equipped with a touch control panel with a built-in temperature sensor. The operating mode of the AHU can be set by using this panel. It is possible to set the required air temperature and monitor the current parameters of the unit and the fan speed.
Control via BMS*	The controller allows for easy organizing data exchange (via ModBus protocols) with other control systems, as well as integrate into the smart home system.
ECO NET	Control the system using a downloaded application from a gadget or PC. Monitoring and control from anywhere in the world.
Display	The control panel screen displays information messages about recorded accidents and faulty ventilation units and their current parameters.

* - in coordination with the manufacturer;

** - only one mode can be selected.



ФУНКЦІЇ ЗАХИСТУ

Fan protection	Continuous monitoring of operation and protection of fans from overheating, overloads and other emergency situations is carried out by built-in fan protection circuits.
Protection of electric heaters	Automation protects both the built-in and additional electric heaters from overheating, using temperature thermostats. When the AHU is turned off, the heating elements are blown until they are cold, and only then is the fan turned off.
Freezing protection of the water heater	Additional sensors continuously monitor the operation of the water heater and its protection against freezing of water in the pipes.
Protection of recuperative heat exchanger from icing	When the outside air temperature drops below -15°C, there is a risk of freezing of the condensate in the recuperative heat exchanger and its damage. The built-in automation system of the units allows for protection to be implemented by using a bypass channel and electric preheating.
Emergency shutdown in case of fire	The AHU is connected to the building's fire safety system and switched off in the event of a fire.
Air temperature protection	When the supply air temperature drops below the minimum allowable value, the unit automatically shuts down.
Protection of actuators	The actuators are protected against short-circuit currents by fuses.
Filter clogging control	The automation constantly records the number of operating hours of the AHU and, upon reaching the set value, signals the need to replace the filter elements.

The main functions and protection functions described above, as well as automatic control systems for AEROSTART-EC-CF air handling units, are implemented in almost all standard sizes and design versions of the AHU.

*To implement a number of functions, the AHU requires the connection of additional instrumentation equipment. Their description and order code can be found in the "Automatic Control System Accessories" section of the catalog.

AEROSTART EC-DX

ceiling-suspended air handling units with heat pump

Ventilation units are designed to organize efficient mechanical supply and exhaust ventilation of various types of premises - ranging from residential premises to commercial construction objects, such as restaurants, shops, office premises, etc.

The units are an alternative solution to classic central air conditioning systems. These ventilation units are characterized by a compact design, a built-in intelligent automatic control system, and ease of start-up, operation, and adjustment.

THE NEW SOLUTION PROVIDES A NUMBER OF BENEFITS:

- ✔ heat savings are achieved through the use of a cross-flow heat recovery unit with an efficiency of up to 70% and a heat pump based on highly efficient sealed compressors. Thus, the heat consumption for heating the air can be reduced several times;
- ✔ insulated casing of the units effectively prevents heat loss, as well as the spread of noise generated by the running fans. The case is covered outside with protective and decorative powder paint, which eliminates the risk of corrosion;
- ✔ low noise is achieved through the use of an effective combination of low-noise fans and a noise-insulated casing;
- ✔ compact fans with EC motors significantly simplify the smooth control of air flow, which is very useful in terms of turning on ventilation as needed;
- ✔ automatic control system is located inside the unit casing. There is no need to look for a place to install an external control cabinet. All air handling units are equipped with a remote control panel;
- ✔ convenient and easy installation. The air handling units are designed according to the plug & play principle - only minimal actions are required for installation, connection and commissioning of the equipment.

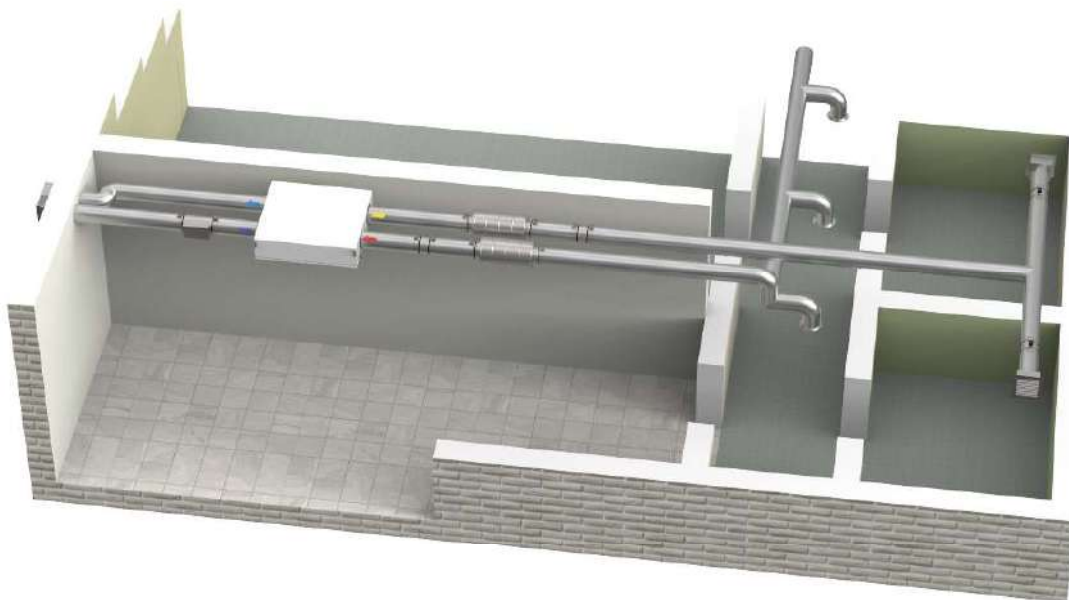



CASING AND INSULATION

The AHU body is made using frameless technologies. The outside panel covering is made of galvanized steel sheets with epoxy-polyester coating, white color. The space between the paneling is filled with non-flammable mineral wool, which features high soundproofing properties. Panels minimize heat losses, ensure tightness of the casing, which prevents the formation of condensation.

COMPRESSOR AND HEAT PUMP

The units use highly efficient sealed compressors, on the basis of which the heat pump is assembled. As a refrigerant, the system uses R407C refrigerant. The system can operate in heating or cooling mode, depending on the mode selection on the control panel.



The design of the air cooler provides for the installation of a Freon heat exchanger and a pan inside the casing.

The evaporator and condenser are made of copper tubes arranged in a staggered order, with aluminum fins. It differs from a water cooler in the design of the distribution unit ("spider") and the specifics of the refrigerant supply.

Freon heat exchanger manifolds are made of copper tubes.

R407C Freon is used as a refrigerant in DX coils.

There are drainage pans under the evaporator and condenser. The pans are equipped with a discharge pipe for condensate draining.

ALUMINUM CROSS-FLOW HEAT EXCHANGER

The heat exchange surface of the heat recovery unit is formed by corrugated plates made of aluminum foil.

OPERATING PRINCIPLE. Exhaust air removed from the serviced premise flows through every second channel between the plates of the recuperative heat exchanger, heating them (in winter) or cooling them (in summer). The processed supply air flows through other channels of the heat exchanger, absorbing the heat of the heated plates or, conversely, cooling down.

At low outdoor temperatures, an additional option (electric heater) must be used to protect the heat recovery unit from icing.

An electric heater is used as an air preheater that is installed upstream the recuperative heat exchanger.

AEROSTART-EC-DX-550-E-G

- ▶ air handling unit
- ▶ type of recuperative heat exchanger used
- ▶ AHU standard size
- ▶ type of optional heater (E – electric, 0 – without heater)
- ▶ type of AHU design version (G - horizontal)

THE MANUFACTURER HAS THE RIGHT TO MAKE CHANGES TO THE DESIGN WITHOUT DETERIORATING ITS CONSUMER PROPERTIES



AEROSTART-EC-DX-550

View T

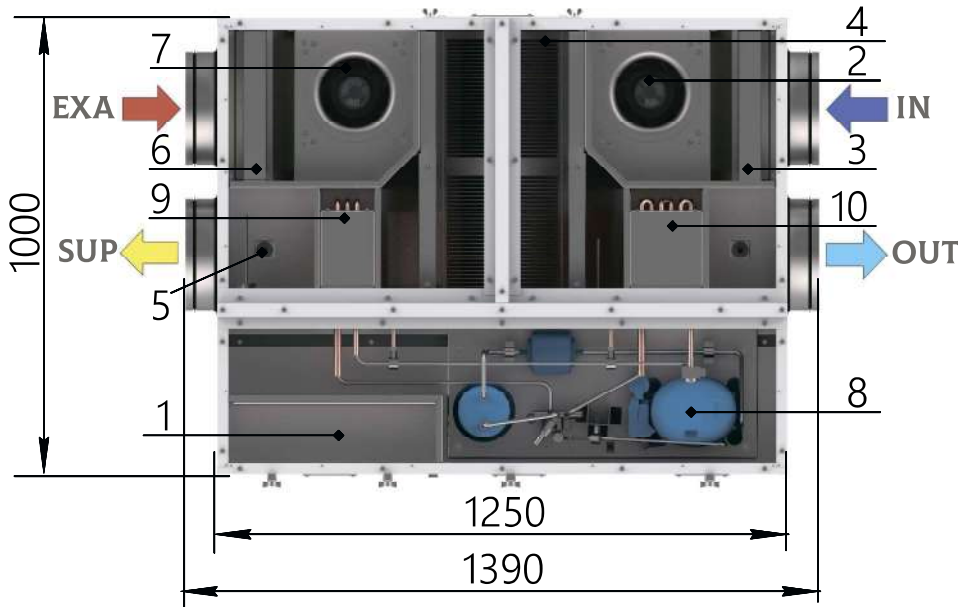

1. Automation system unit
2. Supply air fan
3. Supply air filter
4. Cross-flow recuperative heat exchanger
5. Condensate drain
6. Exhaust air filter
7. Exhaust air fan
8. Compressor and heat pump
9. Freon heat exchanger for supply air
10. Freon heat exchanger for exhaust air

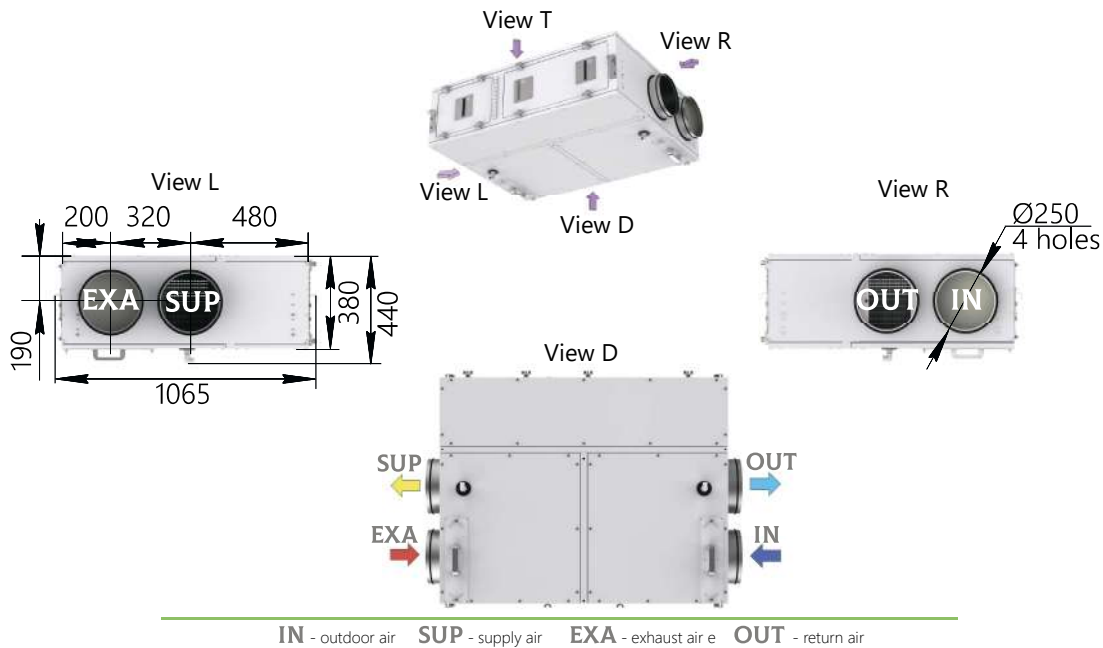

Parameter	VALUE
Nominal air-flow rate*, m ³ /h	550
External static pressure**, Pa	230
Supply voltage	~1 / 220 V / 50 Hz
Fan power (supply/exhaust), kW	0,17/0,17
Electrical power (max) of the built-in compressor, kW	0,71
Total electrical power of the AHU, kW	1,05
Filter (supply/exhaust)	M5/M5
Heating capacity, kW	3,59
Energy efficiency in heating mode (COP)	4,38
Cooling capacity, kW	2,26
Energy efficiency in cooling mode (EER)	2,63
Weight, kg, max	185

* The values are valid under normal conditions for both the supply and exhaust paths.
 ** An example of using the aerodynamic characteristic and temperature efficiency graph is given above.



- air valve
C-KVK-250

- insulated valve
C-GMK-C-40-20

- check valve
C-KOL-K-250

- single leaf damper
C-DKK-250

- duct silencer
C-GKK-250

- duct filter
C-FKK-250

- electric air heater
C-EVN-K-S3-250

- mounting clamp
C-MK-250

- adapter
AD-PSKK-400x200-250

- air intake grille
C-RVK-250

- exhaust grille
C-RVC-250

- supply and exhaust grille
C-RPVC-250

- non-adjustable grille
RKN-250

- water mixing unit
UWS

AEROSTART-EC-DX-550	Sound power level, dB								Total sound pressure level, dB(A)**
	Octave band mid-frequency, Hz*								
	63	125	250	500	1000	2000	4000	8000	
Input	49	52	56	55	53	49	45	41	58
Output	54	57	60	59	57	53	50	46	61
Surrounding	52	52	42	34	37	38	38	35	45

* At nominal flow rate and maximum fan speed.
** Total sound pressure level (not to be confused with power) at a distance of 3 meters.

AERODYNAMIC CHARACTERISTIC AND TEMPERATURE EFFICIENCY

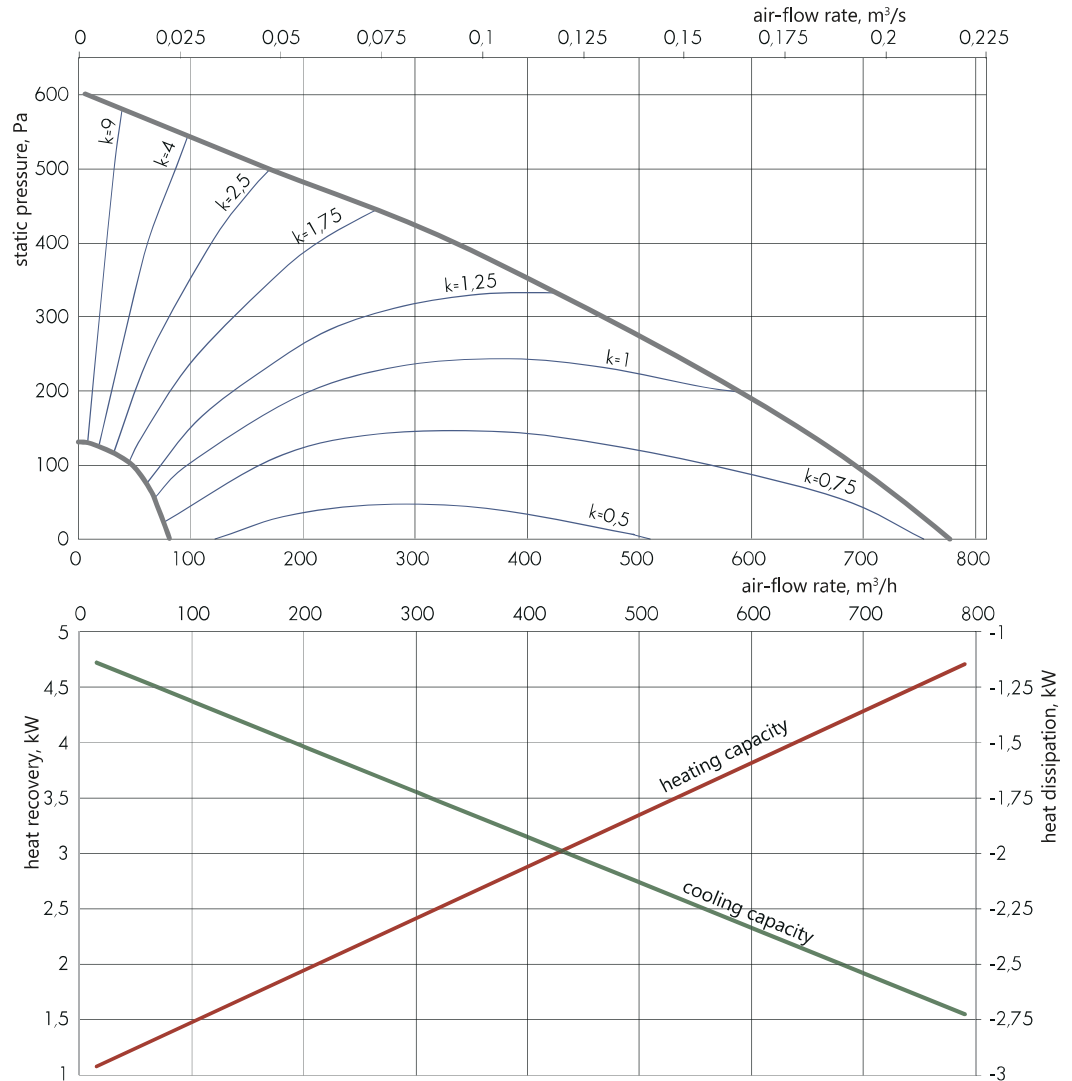

An example of using the aerodynamic characteristic and temperature efficiency graph is given above

Summer conditions. Outdoor air +30°C, humidity 40%. Exhaust air +23°C, humidity 50%.

T evaporation +7°C, T condensation +45°C.

Winter conditions. Outdoor air 0°C, humidity 80%. Exhaust air +22°C, humidity 40%.

T evaporation +5°C, T condensation +40°C.

The AHU uses the electric preheater for heating outdoor air, if its temperature is below -5°C. In addition, the supply air ducts must be insulated.



AEROSTART-EC-DX-900

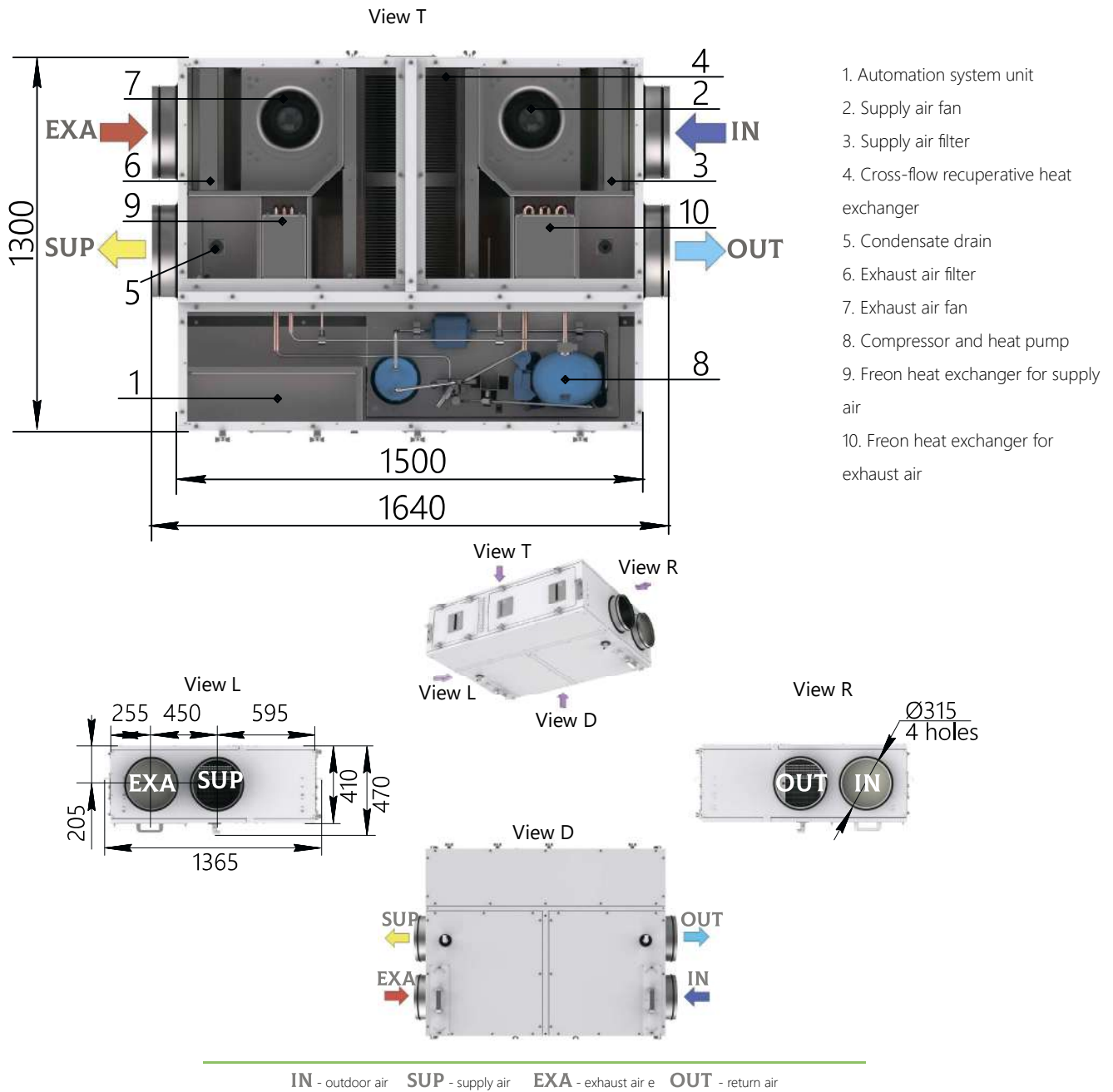

Parameter	VALUE
Nominal air-flow rate*, m ³ /h	900
External static pressure**, Pa	350
Supply voltage	~1 / 220 V / 50 Hz
Fan power (supply/exhaust), kW	0,26/0,26
Electrical power (max) of the built-in compressor, kW	1,48
Total electrical power of the AHU, kW	2
Filter (supply/exhaust)	M5/M5
Heating capacity, kW	5,82
Energy efficiency in heating mode (COP)	3,83
Cooling capacity, kW	3,63
Energy efficiency in cooling mode (EER)	2,26
Weight, kg, max	225

* The values are valid under normal conditions for both the supply and exhaust paths.

** An example of using the aerodynamic characteristic and temperature efficiency graph is given above.

- air valve
C-KVK-315
- insulated valve
C-GMK-C-40-20
- check valve
C-KOL-K-315

- single leaf damper
C-DKK-315

- duct silencer
C-GKK-315

- duct filter
C-FKK-315

- electric air heater
C-EVN-K-S3-315

- mounting clamp
C-MK-315

- adapter
AD-PSKK-400x200-315

- air intake grille
C-RVK-315

- exhaust grille
C-RVC-315

- supply and exhaust grille
C-RPVC-315

- non-adjustable grille
RKN-315

- water mixing unit
UWS

AEROSTART-EC-DX-900	Sound power level, dB								Total sound pressure level, dB(A)**
	Octave band mid-frequency, Hz*								
	63	125	250	500	1000	2000	4000	8000	
Input	57	58	58	57	57	55	52	47	62
Output	62	63	63	62	62	60	57	52	67
Surrounding	60	58	45	37	42	45	45	41	51

* At nominal flow rate and maximum fan speed.

** Total sound pressure level (not to be confused with power) at a distance of 3 meters.

AERODYNAMIC CHARACTERISTIC AND TEMPERATURE EFFICIENCY

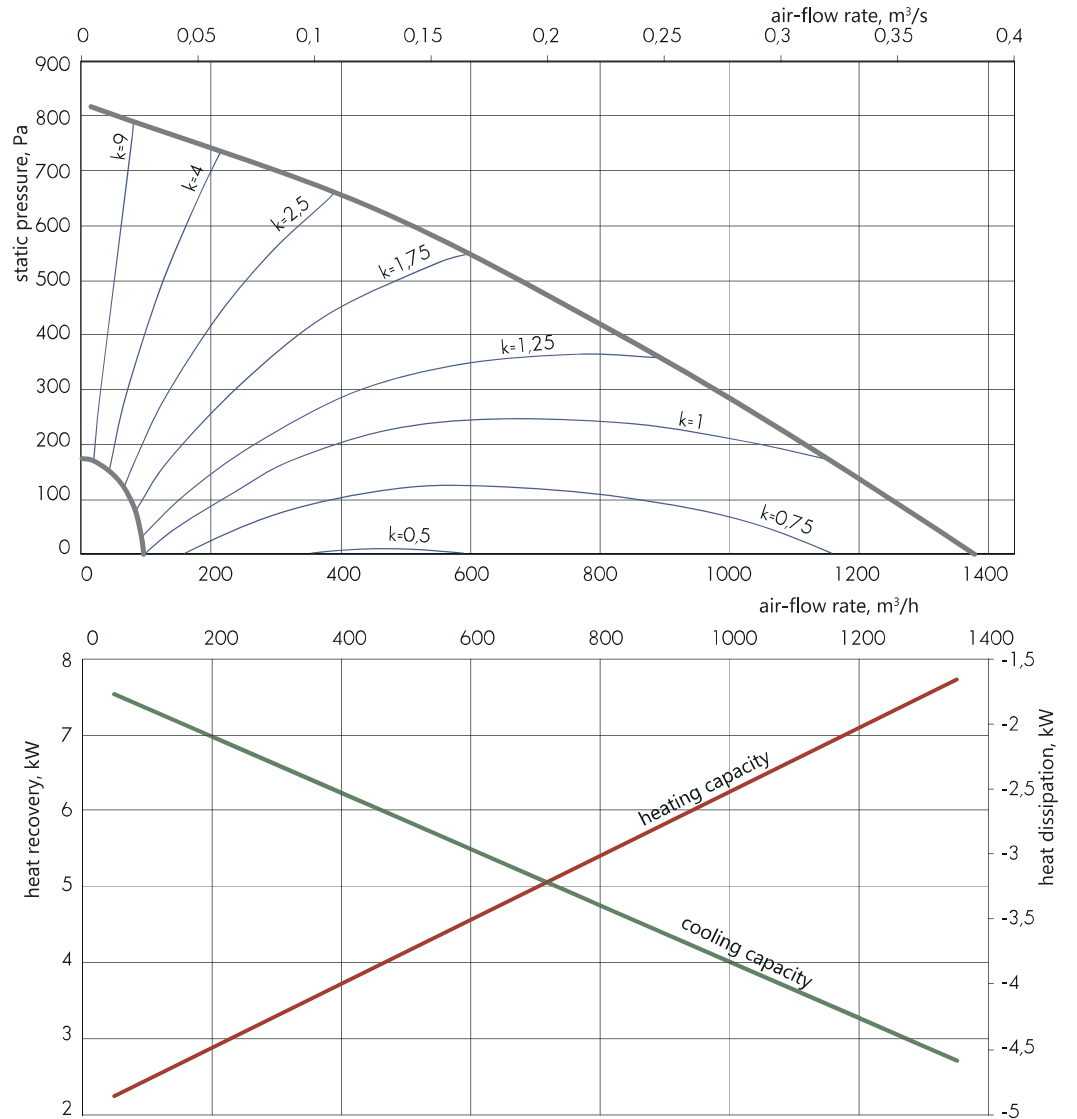

An example of using the aerodynamic characteristic and temperature efficiency graph is given above

Summer conditions. Outdoor air +30°C, humidity 40%. Exhaust air +23°C, humidity 50%.

T evaporation +7°C, T condensation +45°C.

Winter conditions. Outdoor air 0°C, humidity 80%. Exhaust air +22°C, humidity 40%.

T evaporation +5°C, T condensation +40°C.

The AHU uses the electric preheater for heating outdoor air, if its temperature is below -5°C. In addition, the supply air ducts must be insulated.

AEROSTART-EC-DX-1300

View T

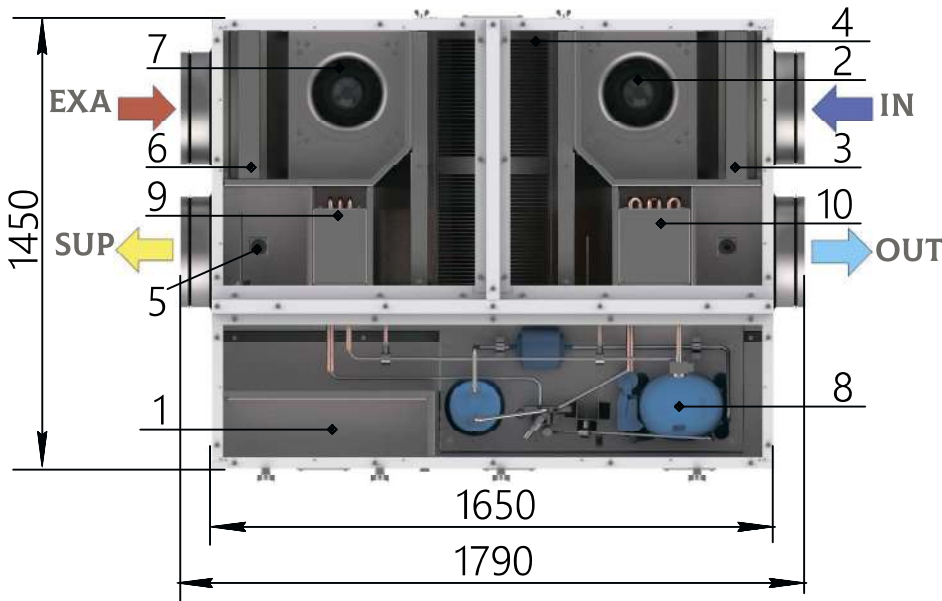

1. Automation system unit
2. Supply air fan
3. Supply air filter
4. Cross-flow recuperative heat exchanger
5. Condensate drain
6. Exhaust air filter
7. Exhaust air fan
8. Compressor and heat pump
9. Freon heat exchanger for supply air
10. Freon heat exchanger for exhaust air

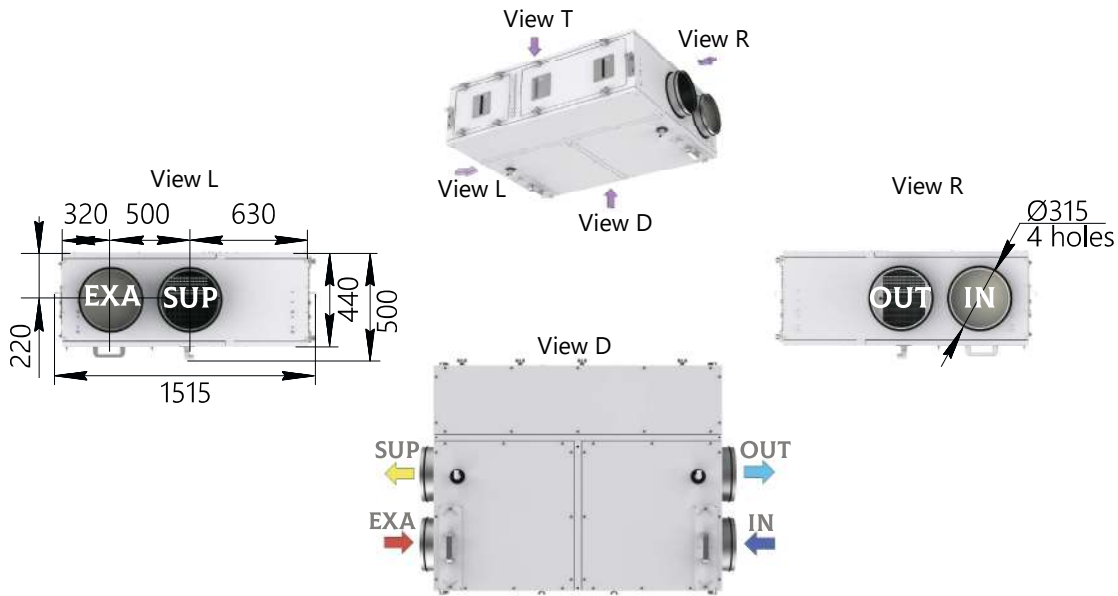

IN - outdoor air SUP - supply air EXA - exhaust air e OUT - return air

Parameter	VALUE
Nominal air-flow rate*, m ³ /h	1300
External static pressure**, Pa	295
Supply voltage	~1 / 220 V / 50 Hz
Fan power (supply/exhaust), kW	0,38/0,38
Electrical power (max) of the built-in compressor, kW	1,8
Total electrical power of the AHU, kW	2,56
Filter (supply/exhaust)	M5/M5
Heating capacity, kW	8,45
Energy efficiency in heating mode (COP)	4,25
Cooling capacity, kW	5,05
Energy efficiency in cooling mode (EER)	2,4
Weight, kg, max	250

* The values are valid under normal conditions for both the supply and exhaust paths.

** An example of using the aerodynamic characteristic and temperature efficiency graph is given above.



air valve
C-KVK-315

insulated valve
C-GMK-C-50-25

check valve
C-KOL-K-315

single leaf damper
C-DKK-315

duct silencer
C-GKK-315

duct filter
C-FKK-315

electric air heater
C-EVN-K-S3-315

mounting clamp
C-MK-315

adapter
AD-PSKK-500x250-315

air intake grille
C-RVK-315

exhaust grille
C-RVC-315

supply and exhaust grille
C-RPVC-315

non-adjustable grille
RKN-315

water mixing unit
UWS

AEROSTART-EC-DX-1300	Sound power level, dB								Total sound pressure level, dB(A)**
	Octave band mid-frequency, Hz*								
	63	125	250	500	1000	2000	4000	8000	
Input	60	62	62	60	60	58	54	50	65
Output	65	67	67	65	65	63	59	55	70
Surrounding	63	62	49	40	45	48	47	44	54

* At nominal flow rate and maximum fan speed.

** Total sound pressure level (not to be confused with power) at a distance of 3 meters.

AERODYNAMIC CHARACTERISTIC AND TEMPERATURE EFFICIENCY

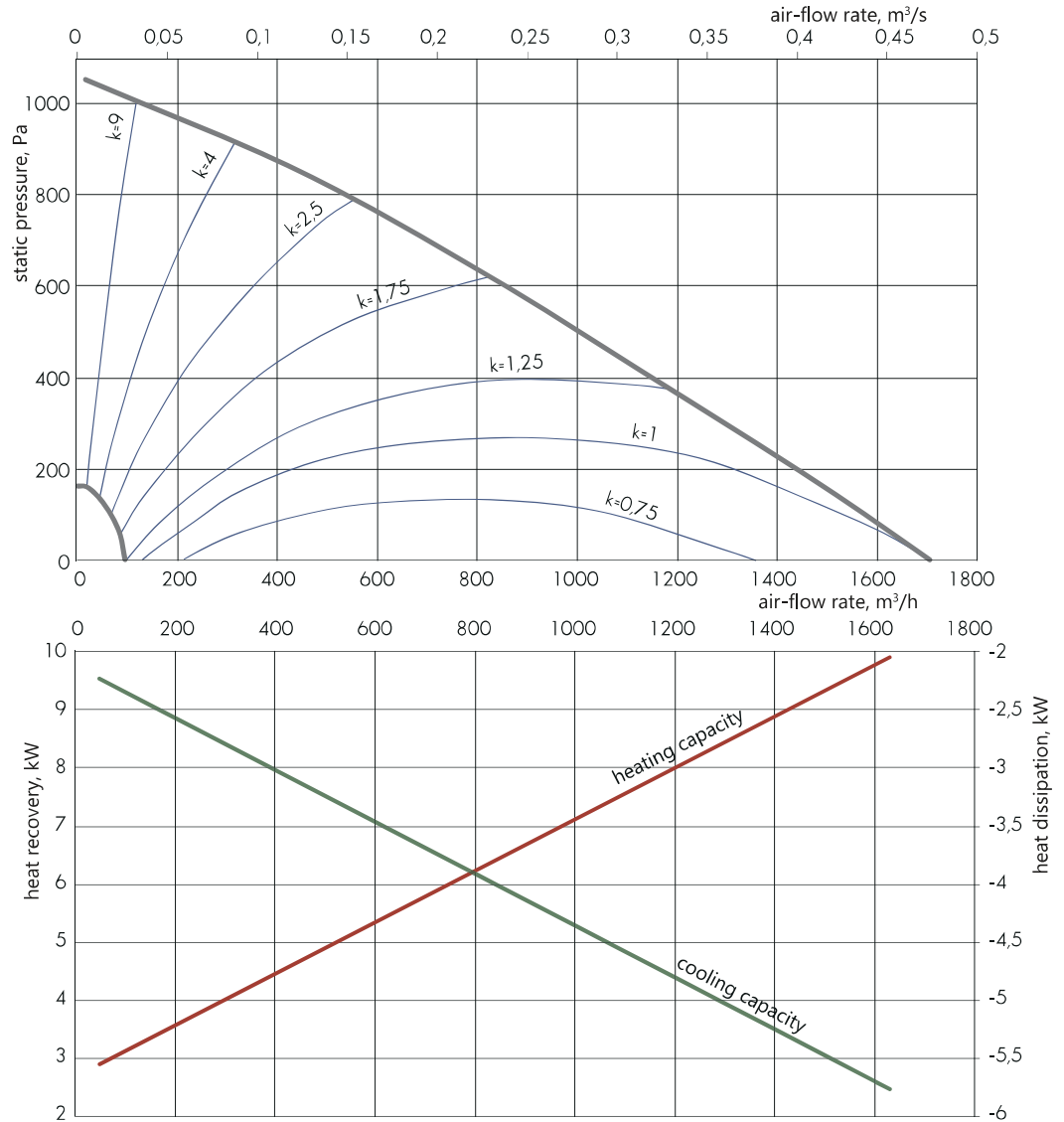

An example of using the aerodynamic characteristic and temperature efficiency graph is given above

Summer conditions. Outdoor air +30°C, humidity 40%. Exhaust air +23°C, humidity 50%.

T evaporation +7°C, T condensation +45°C.

Winter conditions. Outdoor air 0°C, humidity 80%. Exhaust air +22°C, humidity 40%.

T evaporation +5°C, T condensation +40°C.

The AHU uses the electric preheater for heating outdoor air, if its temperature is below -5°C. In addition, the supply air ducts must be insulated.



AEROSTART-EC-DX-2000

View T

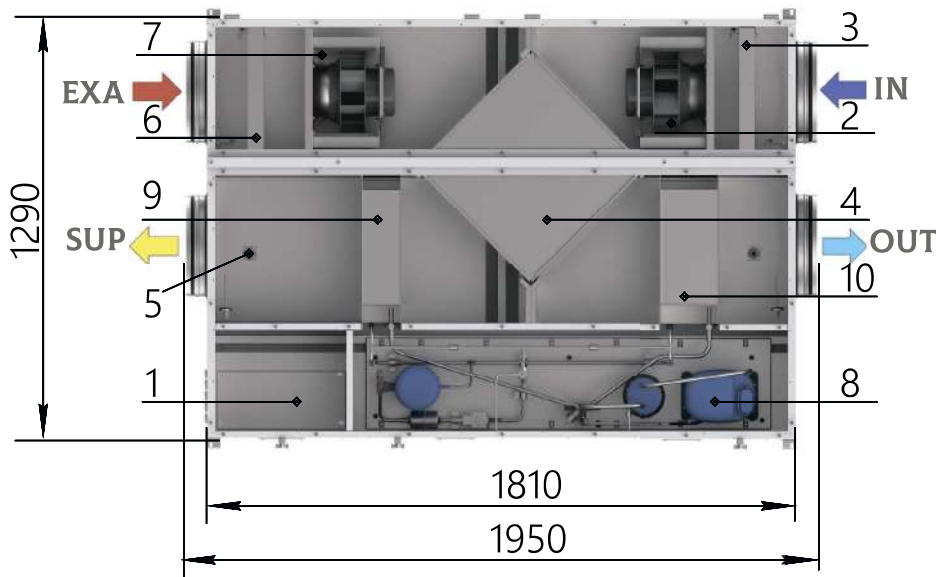

1. Automation system unit
2. Supply air fan
3. Supply air filter
4. Counter-flow recuperative heat exchanger
5. Condensate drain
6. Exhaust air filter
7. Exhaust air fan
8. Compressor and heat pump
9. Freon heat exchanger for supply air
10. Freon heat exchanger for exhaust air

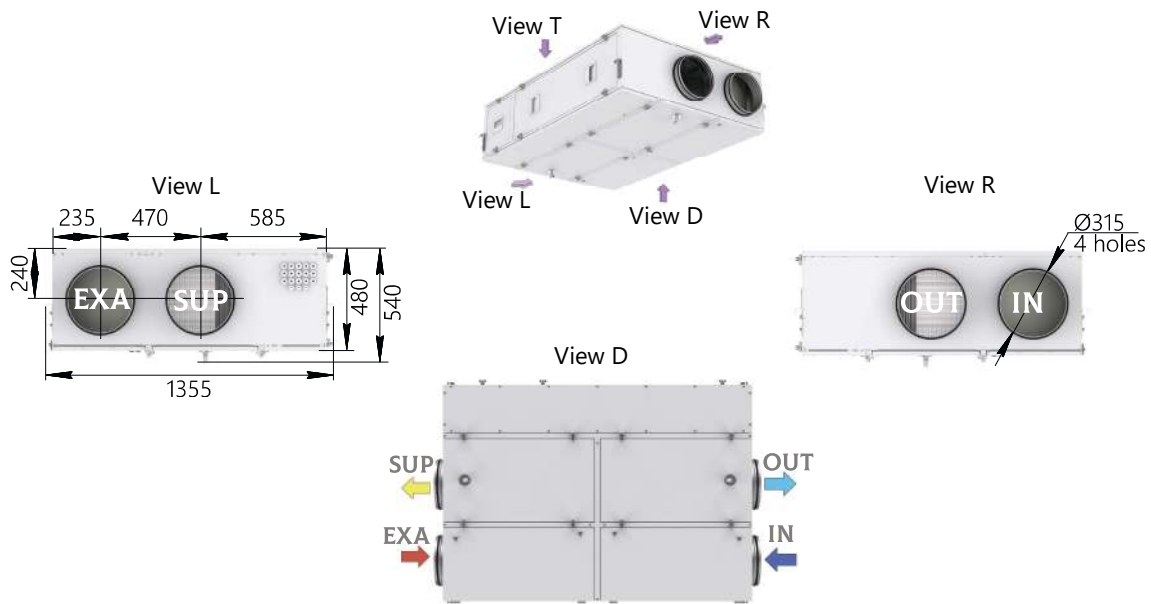

IN - outdoor air SUP - supply air EXA - exhaust air e OUT - return air

Parameter	VALUE
Nominal air-flow rate*, m ³ /h	2 000
External static pressure**, Pa	195
Supply voltage	~1 / 220 V / 50 Hz
Fan power (supply/exhaust), kW	0,75/0,75
Electrical power (max) of the built-in compressor, kW	2,48
Total electrical power of the AHU, kW	3,98
Filter (supply/exhaust)	M5/M5
Heating capacity, kW	11,95
Energy efficiency in heating mode (COP)	3,81
Cooling capacity, kW	7,18
Energy efficiency in cooling mode (EER)	2,19
Weight, kg, max	240

* The values are valid under normal conditions for both the supply and exhaust paths.

** An example of using the aerodynamic characteristic and temperature efficiency graph is given above.



air valve
C-KVK-315

insulated valve
C-GMK-C-50-30

check valve
C-KOL-50-30

single leaf damper
C-DKK-315

duct silencer
C-GKK-315

duct filter
C-FKP-50-30

electric air heater
C-EVN-K-S3-315

mounting clamp
C-MK-315

adapter
AD-PSKK-500x300-315

air intake grille
C-RVK-315

exhaust grille
C-RVC-315

supply and exhaust grille
C-RPVC-315

non-adjustable grille
RKN-315

water mixing unit
UWS

AEROSTART-EC-DX-2000	Sound power level, dB								Total sound pressure level, dB(A)**
	Octave band mid-frequency, Hz*								
	63	125	250	500	1000	2000	4000	8000	
Input	56	54	60	62	59	60	60	57	67
Output	58	57	61	65	66	68	66	62	73
Surrounding	56	52	43	40	46	53	54	51	59

* At nominal flow rate and maximum fan speed.

** Total sound pressure level (not to be confused with power) at a distance of 3 meters.

AERODYNAMIC CHARACTERISTIC AND TEMPERATURE EFFICIENCY

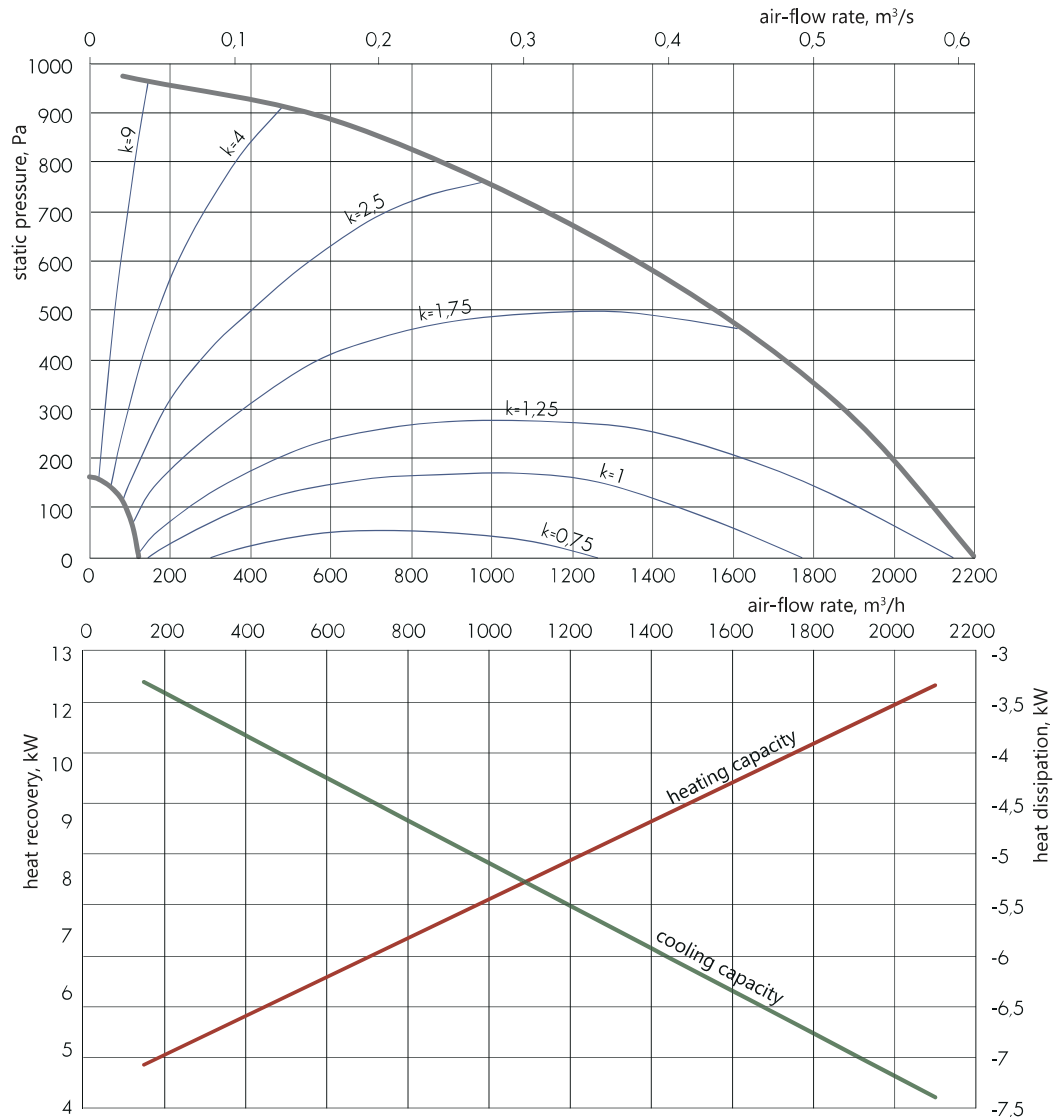

An example of using the aerodynamic characteristic and temperature efficiency graph is given above

Summer conditions. Outdoor air +30°C, humidity 40%. Exhaust air +23°C, humidity 50%.

T evaporation +7°C, T condensation +45°C.

Winter conditions. Outdoor air 0°C, humidity 80%. Exhaust air +22°C, humidity 40%.

T evaporation +5°C, T condensation +40°C.

The AHU uses the electric preheater for heating outdoor air, if its temperature is below -5°C. In addition, the supply air ducts must be insulated.



AUTOMATIC CONTROL SYSTEM

The automatic control system is used for power supply and automated control of AEROSTART-EC-DX air handling units. Intelligent software allows for the implementation of a wide range of functions of the unit and provides reliable control and monitoring algorithms.

Structurally, the automation system is located in the AEROSTART-EC-DX air handling unit casing. All assemblies and monitoring and control devices that are located inside the AHU are already connected and ready for operation. The AEROSTART-EC-DX units are manufactured on the plug & play principle, which, combined with the built-in intelligent automation, reduces the cost of installation work, and also facilitates the start-up of installations and their commissioning.

The units are controlled by a remote control, which is always included in the delivery package. The control panel features a modern design, which allows it to be conveniently integrated into the interior of any room. A 16 m long switching cable is supplied with the control panel.

The built-in automation system ensures not only optimal operation control, but also safe operation of the AHU.

The units can also be controlled via the RS-485 interface network.





MAIN FUNCTIONS

Air temperature control	The unit automatically maintains the supply air temperature according to the set value. Monitoring is carried out by the air temperature sensor inside the duct and the indoor air temperature sensor.
Air valve control	Air valves are not included in the AEROSTART-EC units and are classified as accessories. However, the integrated automation system of units provides for controlling the operation of electric drives of air intake valves, both with and without a return spring. It provides connection and power supply of perimeter heating of air valves, which are used in regions with low outdoor temperatures. Standard power supply for valve electric drives is 220 V.
Control of an additional electric preheater	Protection of the recuperative heat exchanger from icing can be realized by organizing preheating the outdoor air. The built-in automation system provides discrete power control of the external electric preheater C-EVN-K-S2. Power supply and protection are provided by the customer!
Scheduled operation	The unit controller provides the ability to program both by daily hours and by days of the week.
AHU control using the control panel	All air handling units are equipped with a control panel. The operating mode of the AHU can be set by using this panel. It is possible to set the required air temperature and monitor the current parameters of the unit and the fan speed.
Control via BMS	The controller allows for easy organizing data exchange (via ModBus protocols) with other control systems, as well as integrate into the smart home system.
Display	The control panel screen displays information messages about recorded failures and malfunctions of the unit, as well as current parameters.
Fan and compressor protection	Continuous monitoring of operation and protection of fans from overheating, overloads and other emergency situations is carried out.
Optional heater control	Automation protects the additional electric heater from overheating using temperature thermostats. When the AHU is turned off, the heating elements are blown until they are cold, and only then is the fan turned off.
Protection of recuperative heat exchanger from icing	When the outside air temperature drops below -5° C, there is a risk of freezing of the condensate in the recuperative heat exchanger and its damage. The built-in automation system of the units allows for protection to be implemented by using electric preheating.
Emergency shutdown in case of fire	The AHU is connected to the building's fire safety system and switched off in the event of a fire.
Air temperature protection	When the supply air temperature drops below the minimum allowable value, the unit automatically shuts down.
Protection of actuators	The actuators are protected against short-circuit currents by fuses.
Filter clogging control	The automation constantly records the number of operating hours of the AHU and, upon reaching the set value, signals the need to replace the filter elements.

DISPATCHING AND MODBUS

The AHU can be controlled by a central automation system using Modbus. The panel comes standard with an I/O dry contact. The unit can be turned on or off, and all malfunctions can be monitored using BMS.

All heat recovery functions can be controlled and monitored by the system using Modbus control.



AEROSMART-EC

air handling unit with rotary heat exchanger

Ventilation units of the AEROSMART-EC series are designed for the organization of efficient mechanical supply and exhaust ventilation of various types of premises - ranging from residential premises to commercial construction objects, such as restaurants, shops, office premises, etc. The units are an alternative solution to classic central air conditioning systems. These ventilation units are characterized by compact design, built-in intelligent automatic control system, and ease of start-up and adjustment.

BENEFITS:

- ✔ heat savings are achieved through the use of a rotary heat recovery unit with an efficiency of up to 90%. Thus, the heat consumption for heating the air can be reduced by more than 10 times;
- ✔ compact fans with EC motors significantly simplify the smooth control of air flow, which is very useful in terms of turning on ventilation as needed;
- ✔ low noise is achieved through the use of an effective combination of low-noise fans and a noise-insulated casing;
- ✔ insulated housing of AEROSMART-EC units effectively prevents heat loss, as well as the spread of noise generated by the running fans. The case is covered outside with protective and decorative powder paint, which eliminates the risk of corrosion.



- ✔ automation system is located inside the casing of AEROSMART-EC units. There is no need to look for a place to install an external control cabinet. All air handling units are equipped with a remote control panel;
- ✔ convenient and easy installation. AEROSMART-EC air handling units are designed according to the plug & play principle - only minimal actions are required for installation, connection and commissioning of the equipment.

PERFORMANCE RANGE

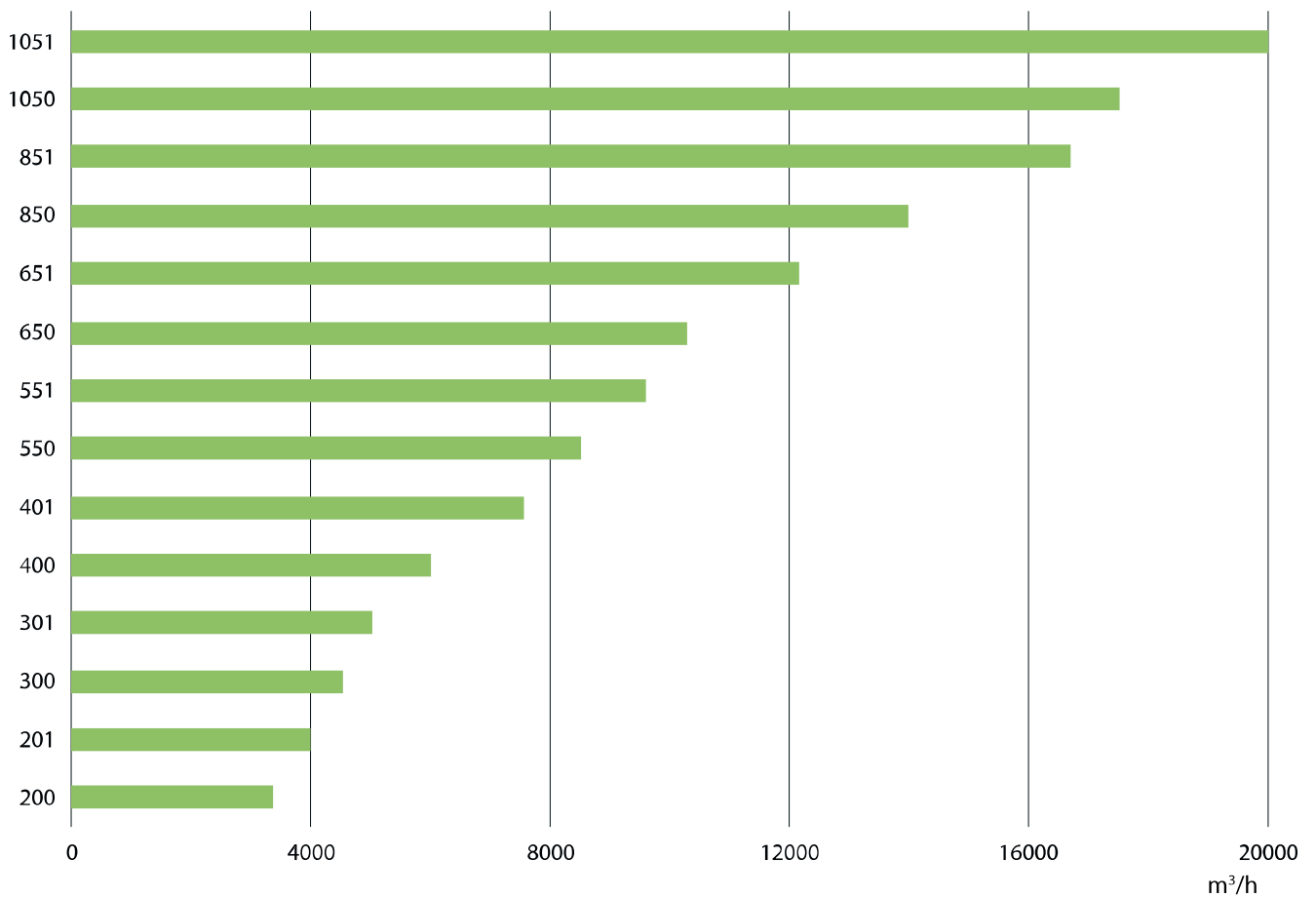

AEROSMART-EC-550-BL-H-O

- ▶ air handling unit
- ▶ AHU standard size
 (200, 201, 300, 301, 400, 401, 550, 551, 650, 651, 850, 851, 1050, 1051)
- ▶ design designation
 (MB – monoblock design of the unit casing (only for 200 and 201)
 BL - modular design of the unit casing)
- ▶ branch pipes orientation direction
 (H – pipes for connecting horizontal air ducts
 V - pipes for connecting vertical air ducts (only for 200; 201÷400; 401))
- ▶ internal identifier

CASING

AEROSMART-EC air handling units are made using frameless technologies. The panels are covered outside with galvanized steel sheets with epoxy-polyester coating, color RAL9016. The space between the panels is filled with polyurethane foam or non-flammable mineral wool, which features high soundproofing properties. Panels minimize heat losses, ensure tightness of the casing, which prevents the formation of condensation

FANS

Inside the casing, there are fans with electronically commutated (EC) motors that provide supply and exhaust of the air.

It's a structure in which the motor is integrated with the impeller. EC electric motors provide low power consumption and compact dimensions. Since EC motors feature a built-in speed controller, these fans do not require an additional frequency converter to regulate capacity.

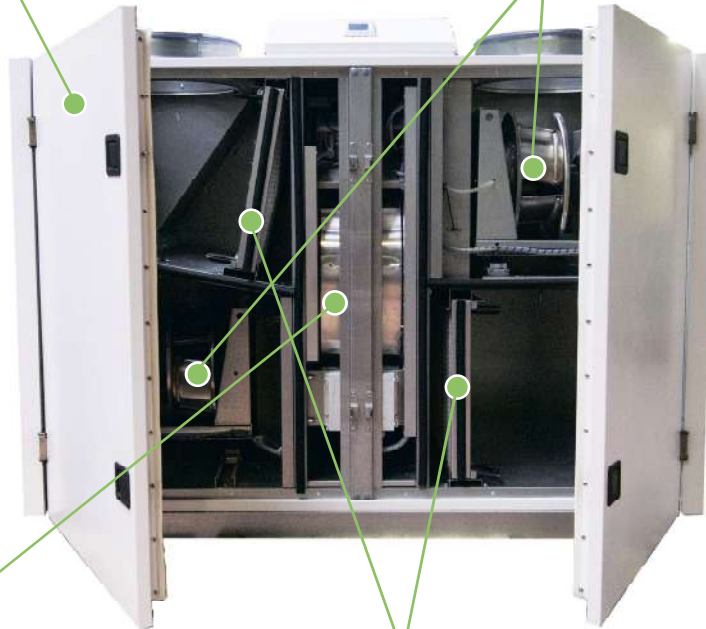

RECUPERATIVE HEAT EXCHANGER

Rotary heat exchangers are used to complete the AEROSMART-EC units, where the rotor is an accumulating mass made of profiled duralumin foil, which is wound in the form of a wheel. The rotor, under the control of a stepper motor drive, changes its speed and achieves its maximum efficiency, which can reach 90%.

Thanks to this operation, the rotor significantly saves energy costs for heating the supply air.

FILTERS

Filters are designed to remove solid and fibrous particles from the supply and exhaust air.

AEROSMART-EC air handling units use compact flat fine filters of M5 filtration class. A higher degree of air purification can be provided by using other devices located outside the AHU. The filter elements are inserted into frames and installed on special guides in the filter block housing and are removed from the service side. Frames and guides prevent air flow and allow for maintenance by easily removing them from the unit casing for replacement.

AUTOMATIC CONTROL SYSTEM

In AEROSMART-EC air handling units of sizes 200-500, the automatic control system cabinet is located on top of the unit above the rotary heat exchanger. In older models, the automatic control system cabinet is located completely inside the rotary heat exchanger unit.

The automatic control system includes a controller, an instrumentation equipment, a control panel and other control and protection elements of the AHU. All sensors necessary for the operation of the unit are installed inside the ventilation unit at the manufacturing plant. At the same time, in addition to placement, sensors and electrical actuators (fan motors, electric drive of a rotary heat exchanger) are electrically connected to the cabinet of the automatic control system.

DESIGN VERSION

AEROSMART-EC air handling units are manufactured exclusively in floor-standing design and are equipped with a 100 mm high support frame. The casing design options allow for offering the customer units adapted for both horizontal and vertical connection. This is true for standard sizes 200; 201-400; 401. For older models, the connection of air ducts is only horizontal.



HORIZONTAL CONNECTION



VERTICAL CONNECTION

The newest model of the standard size line (AEROSMART-EC-200 and AEROSMART-EC-201) is manufactured both in a modular design and in a monoblock one. The monoblock design is characterized by manufacturing the unit in a single casing. The modular design involves dividing the unit lengthwise into three transport sections. The modular design of the casing is valid for all standard sizes of the AEROSMART-EC air handling unit.



MODULAR DESIGN



MONOBLOCK DESIGN



EXAMPLE OF USING THE AERODYNAMIC CHARACTERISTIC AND TEMPERATURE EFFICIENCY GRAPH OF AN INTEGRATED RECUPERATIVE HEAT EXCHANGER

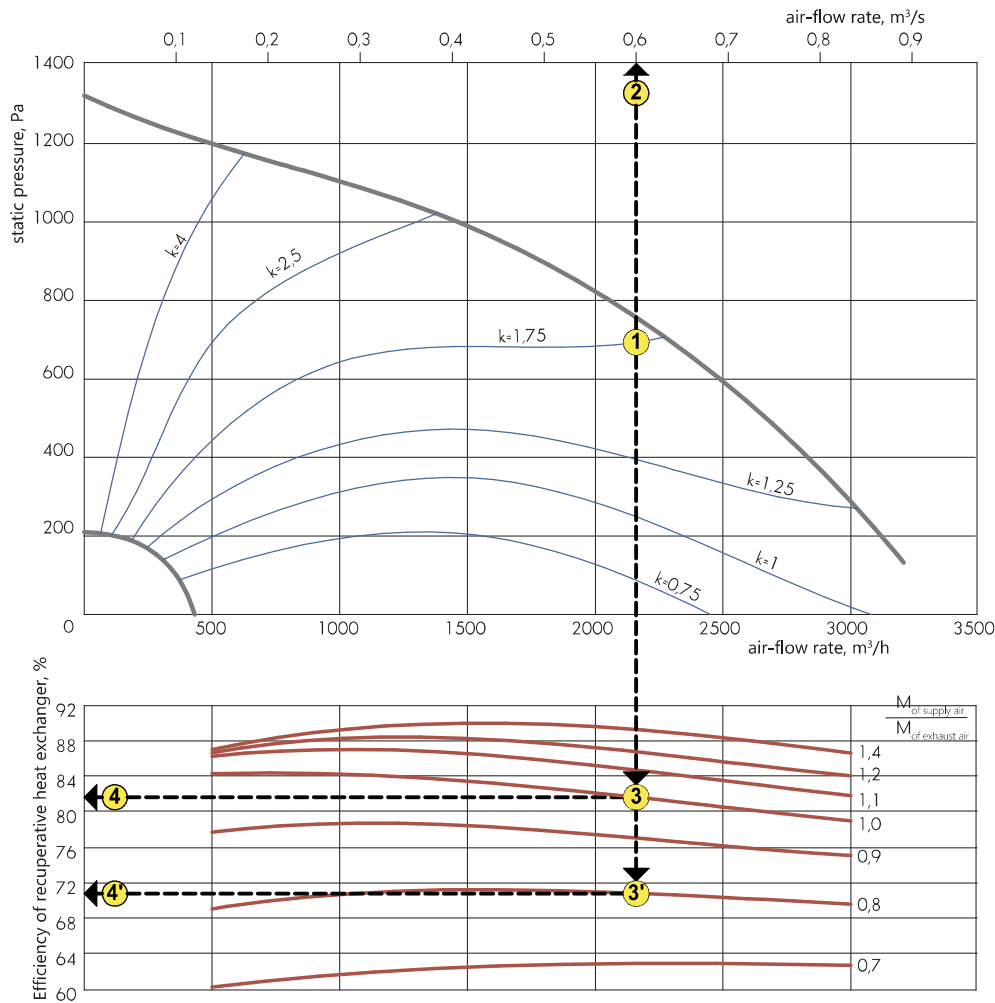

By selecting the required operating point on the aerodynamic diagram, we can determine the following:

- fan power consumption;
- Efficiency of the recuperative heat exchanger for any flow rate within the operating range of the AHU, taking into account the difference in mass flow rates of outdoor and exhaust air.

EXAMPLE:

The AEROSMART-EC-200 unit operates with an intake air flow rate of 2160 m³/h at static pressure of 750 Pa, which corresponds to point 1.

In this case, we see that the closest curve to point 1 characterizing the fan power is the curve $k = 1.75$. Following from point 1 vertically upwards to point 2, we obtain a volumetric flow rate of 0.6 m³/s.

Then, knowing the volumetric flow rate of the supply fan, we can calculate the power consumed by it using the formula:

$$N[\text{kW}] = k[\text{kW}/(\text{m}^3/\text{s})] \times L[\text{m}^3/\text{s}] = 1.75 \times 0.6 = 1.05 \text{ kW.}$$

Further, going down from point 1 to the graph of the temperature efficiency of the built-in recuperative heat exchanger, we can determine its efficiency.

For equal mass flow rates of outdoor and exhaust air ($M_{\text{of exhaust air}}/M_{\text{of supply air}} = 1$), the efficiency of the recuperative heat exchanger will be about 82% (points 3-4).

For the case when the ratio of outdoor and exhaust air flow rates is different, the efficiency of the recuperative heat exchanger will also change its value.

FOR EXAMPLE for the ratio of $M_{\text{of exhaust air}}/M_{\text{of supply air}} = 0.8$, the exhaust air flow rate will be:

$$M_{\text{of exhaust air}} = M_{\text{of supply air}} \times 0.8 = 2.160 \times 0.8 = 1.728 \text{ m}^3/\text{h.}$$

In this case, from point 1, we move down to the intersection with the curve $M_{\text{of exhaust air}}/M_{\text{of supply air}} = 0.8$ (point 3) and then we determine the efficiency of the recuperative heat exchanger - about 71% (point 4).





AEROSMART-EC-200

Parameter	VALUE
Nominal air-flow rate*, m ³ /h	2000
External static pressure*, Pa	815
Maximum air flow rate (at static pressure 200 Pa), m ³ /h	3120
Supply voltage	~3/ 380 V/ 50 Hz
Fan power (supply/exhaust), kW	1,05/1,05
Total electrical power of the AHU, kW	2,24
Filter (supply/exhaust)	M5/M5
Weight, kg, max	393

* The values are valid under normal conditions for both the supply and exhaust paths.

AERODYNAMIC CHARACTERISTICS

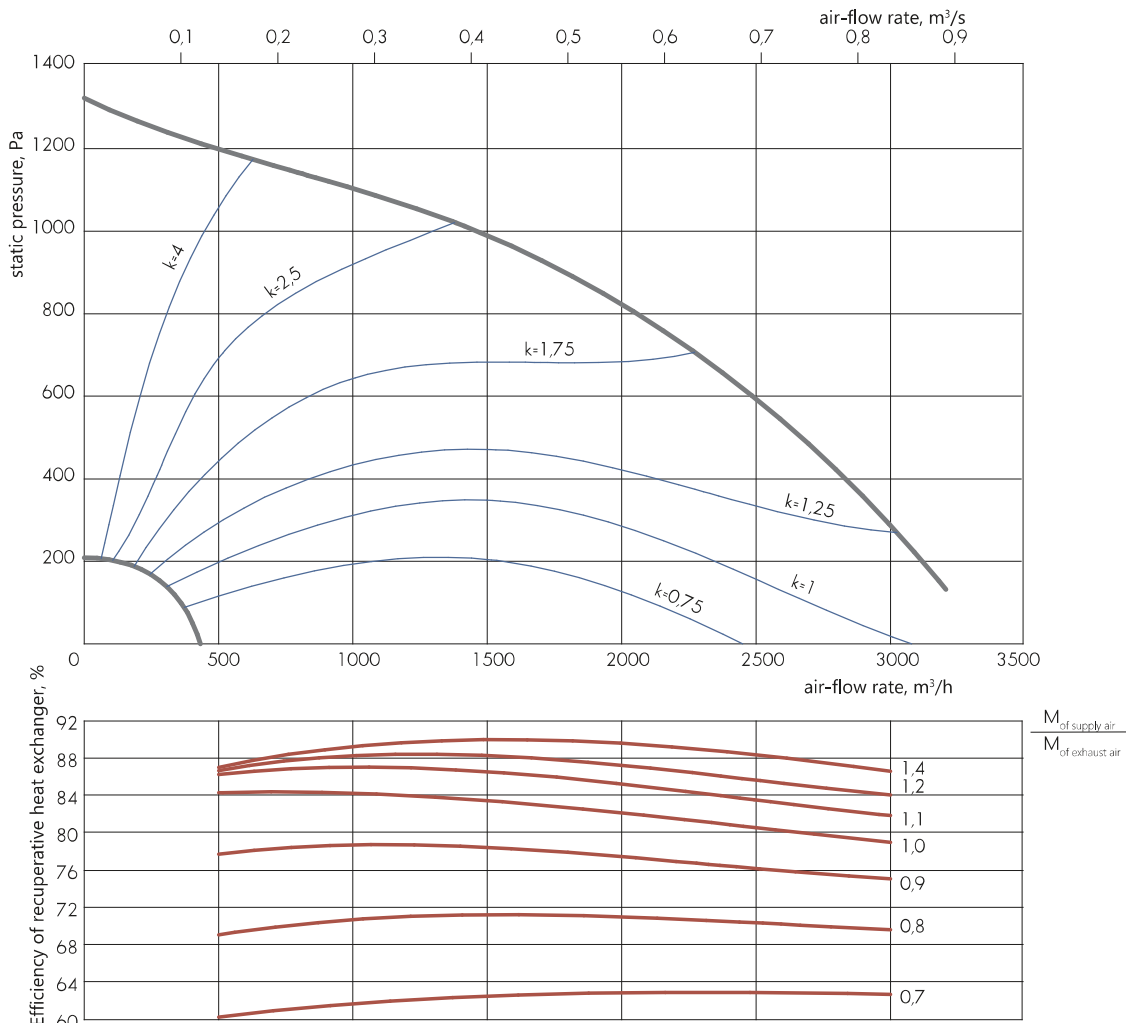

The temperature efficiency graph is shown at the same supply and exhaust air flow rates, and at the exhaust air temperature t = +20° C, relative humidity rh = 50%

AEROSMART-EC-200	Sound power level, dB								Total sound pressure level, dB(A)**
	Octave band mid-frequency, Hz*								
	63	125	250	500	1000	2000	4000	8000	
Input	60	56	58	61	52	49	45	43	60
Output	65	65	73	70	68	66	62	61	73
Surrounding	63	60	55	45	48	51	50	50	57

* At nominal flow rate and maximum fan speed.

** Total sound pressure level (not to be confused with power) at a distance of 3 meters.

AIR HANDLING UNITS

68

An example of using the aerodynamic characteristic and temperature efficiency graph is given above.





AEROSMART-EC-201

Parameter	VALUE
Nominal air-flow rate*, m ³ /h	2000
External static pressure*, Pa	855
Maximum air flow rate (at static pressure 200 Pa), m ³ /h	3630
Supply voltage	~3/ 380 V/ 50 Hz
Fan power (supply/exhaust), kW	1,23/1,23
Total electrical power of the AHU, kW	2,6
Filter (supply/exhaust)	M5/M5
Weight, kg, max	395

* The values are valid under normal conditions for both the supply and exhaust paths.

AERODYNAMIC CHARACTERISTICS

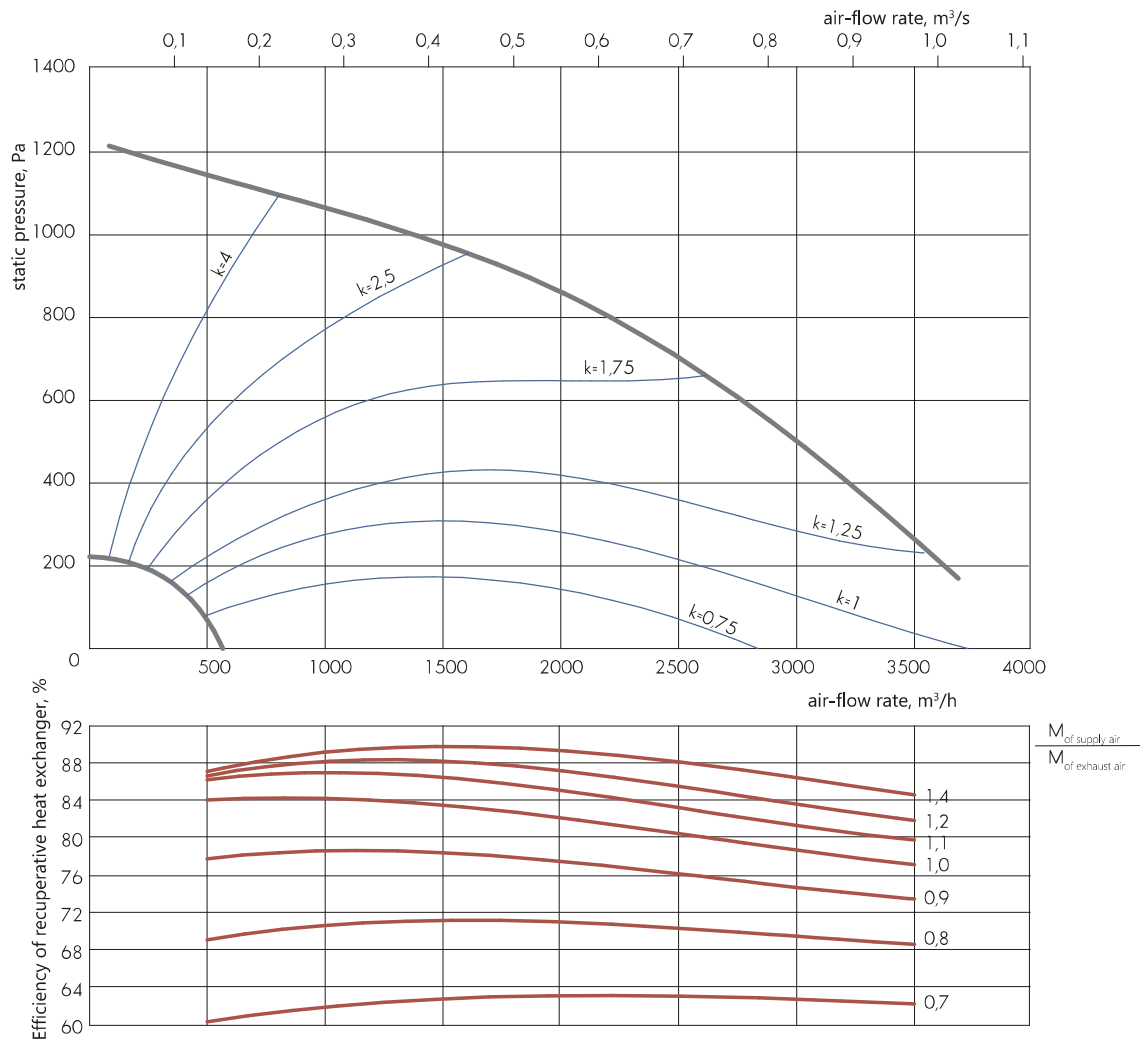

The temperature efficiency graph is shown at the same supply and exhaust air flow rates, and at the exhaust air temperature $t = +20^{\circ}\text{C}$, relative humidity $rh = 50\%$

AEROSMART-EC-201	Sound power level, dB								Total sound pressure level, dB(A)**
	Octave band mid-frequency, Hz*								
	63	125	250	500	1000	2000	4000	8000	
Input	68	63	69	66	51	47	44	37	65
Output	69	68	83	73	69	66	62	58	77
Surrounding	67	63	65	65	49	51	50	47	60

* At nominal flow rate and maximum fan speed.

** Total sound pressure level (not to be confused with power) at a distance of 3 meters.

An example of using the aerodynamic characteristic and temperature efficiency graph is given above.



AEROSMART-EC-200/201

MONOBLOCK DESIGN

HORIZONTAL CONNECTION

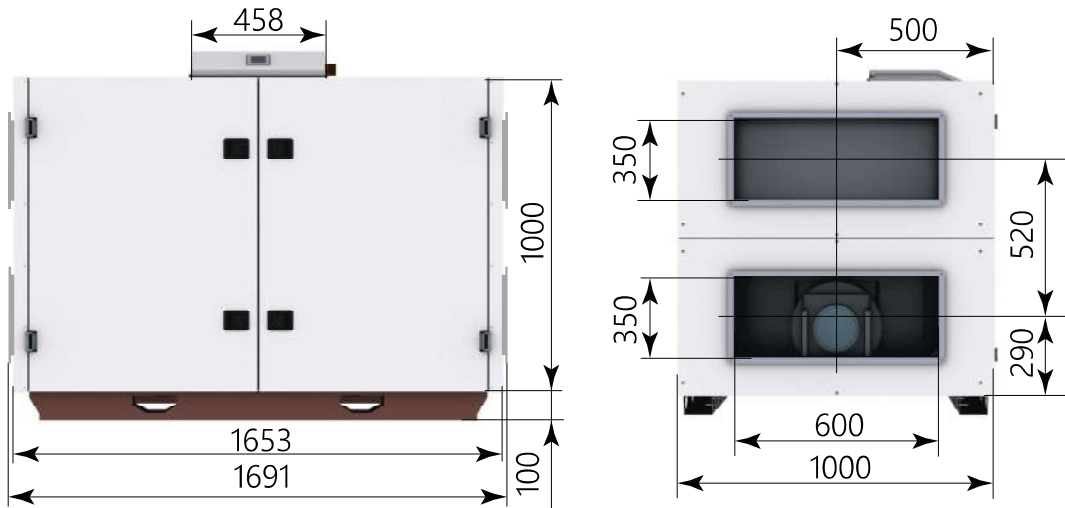

VERTICAL CONNECTION

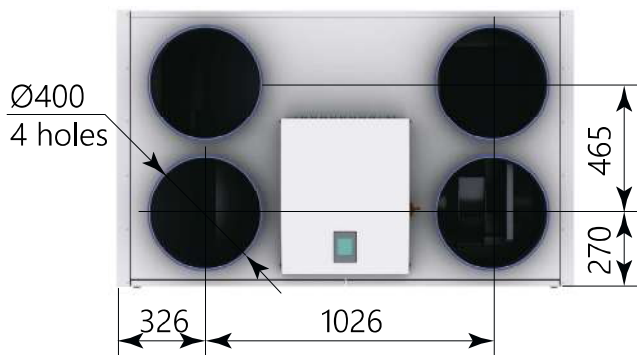
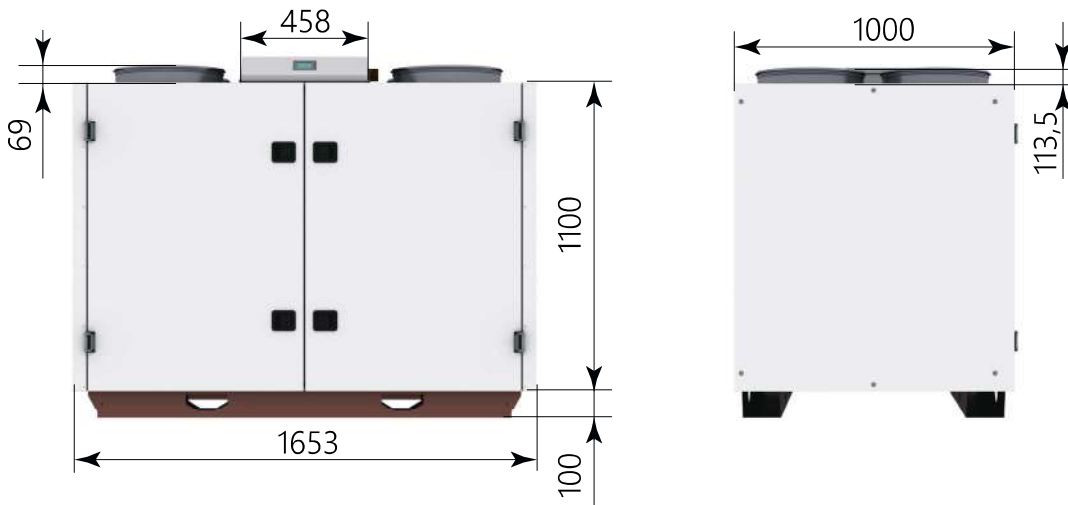

MODULAR DESIGN

HORIZONTAL CONNECTION

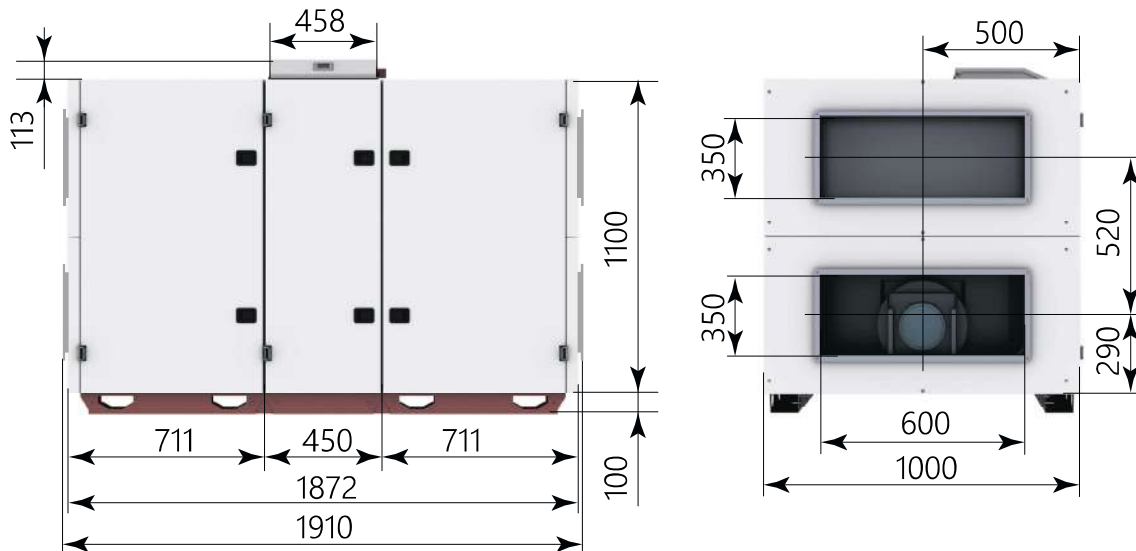

VERTICAL CONNECTION

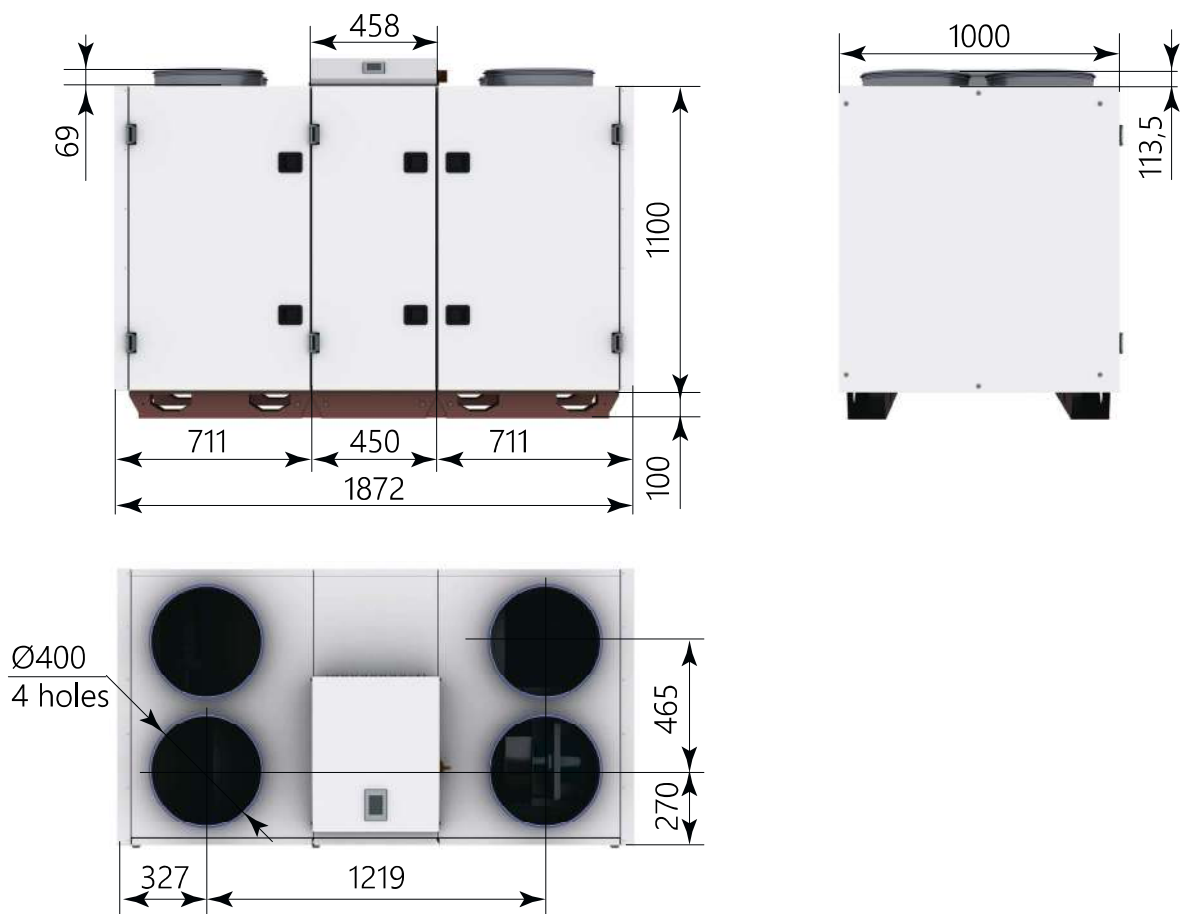



AEROSMART-EC-300

Parameter	VALUE
Nominal air-flow rate*, m ³ /h	3000
External static pressure*, Pa	640
Maximum air flow rate (at static pressure 200 Pa), m ³ /h	4110
Supply voltage	~3/380 V/ 50 Hz
Fan power (supply/exhaust), kW	1,27/1,27
Total electrical power of the AHU, kW	2,68
Filter (supply/exhaust)	M5/M5
Weight, kg, max	485

* The values are valid under normal conditions for both the supply and exhaust paths.

AERODYNAMIC CHARACTERISTICS

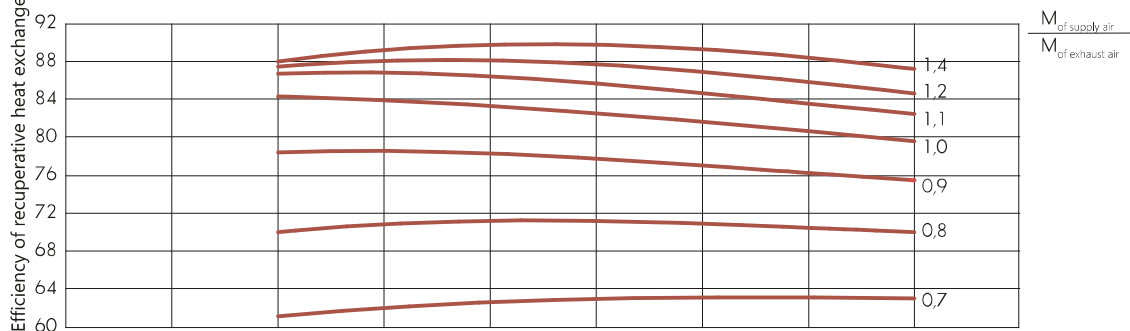
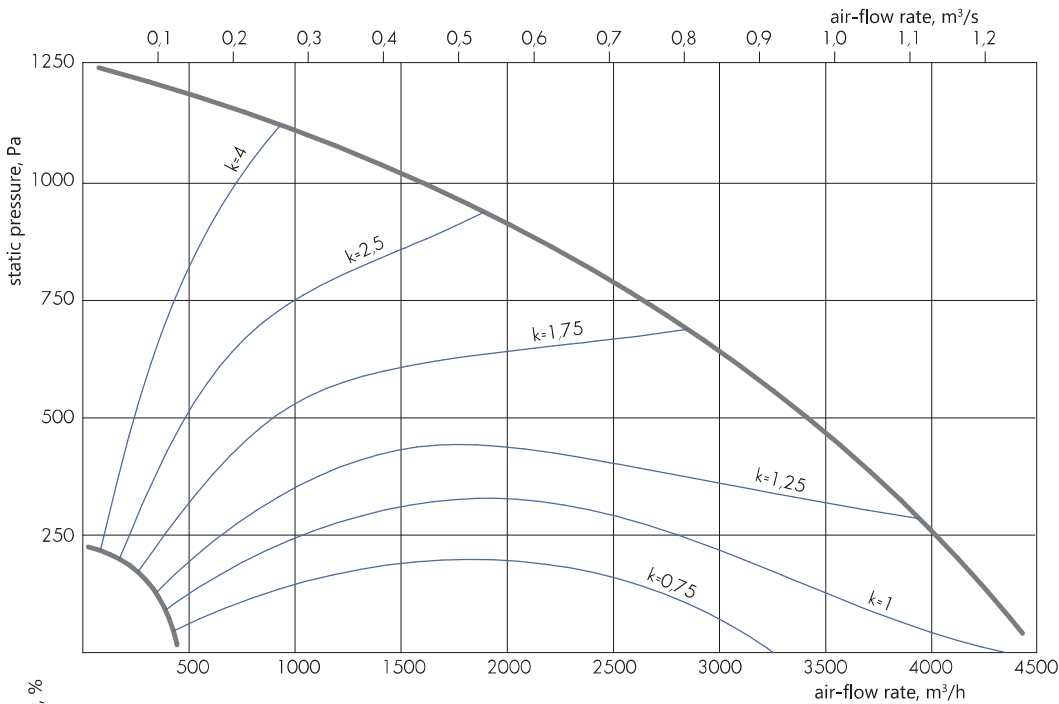

The temperature efficiency graph is shown at the same supply and exhaust air flow rates, and at the exhaust air temperature t = +20° C, relative humidity rh = 50%

AEROSMART-EC-300	Sound power level, dB								Total sound pressure level, dB(A)**
	Octave band mid-frequency, Hz*								
	63	125	250	500	1000	2000	4000	8000	
Input	60	53	58	57	51	49	46	41	58
Output	64	60	68	67	70	70	67	64	75
Surrounding	62	55	50	42	50	55	55	53	60

* At nominal flow rate and maximum fan speed.

** Total sound pressure level (not to be confused with power) at a distance of 3 meters.

AIR HANDLING UNITS

72

An example of using the aerodynamic characteristic and temperature efficiency graph is given above.





AEROSMART-EC-301

Parameter	VALUE
Nominal air-flow rate*, m ³ /h	3000
External static pressure*, Pa	1025
Maximum air flow rate (at static pressure 200 Pa), m ³ /h	4700
Supply voltage	~3/ 380 V/ 50 Hz
Fan power (supply/exhaust), kW	1,8/1,8
Total electrical power of the AHU, kW	3,74
Filter (supply/exhaust)	M5/M5
Weight, kg, max	485

* The values are valid under normal conditions for both the supply and exhaust paths.

AERODYNAMIC CHARACTERISTICS

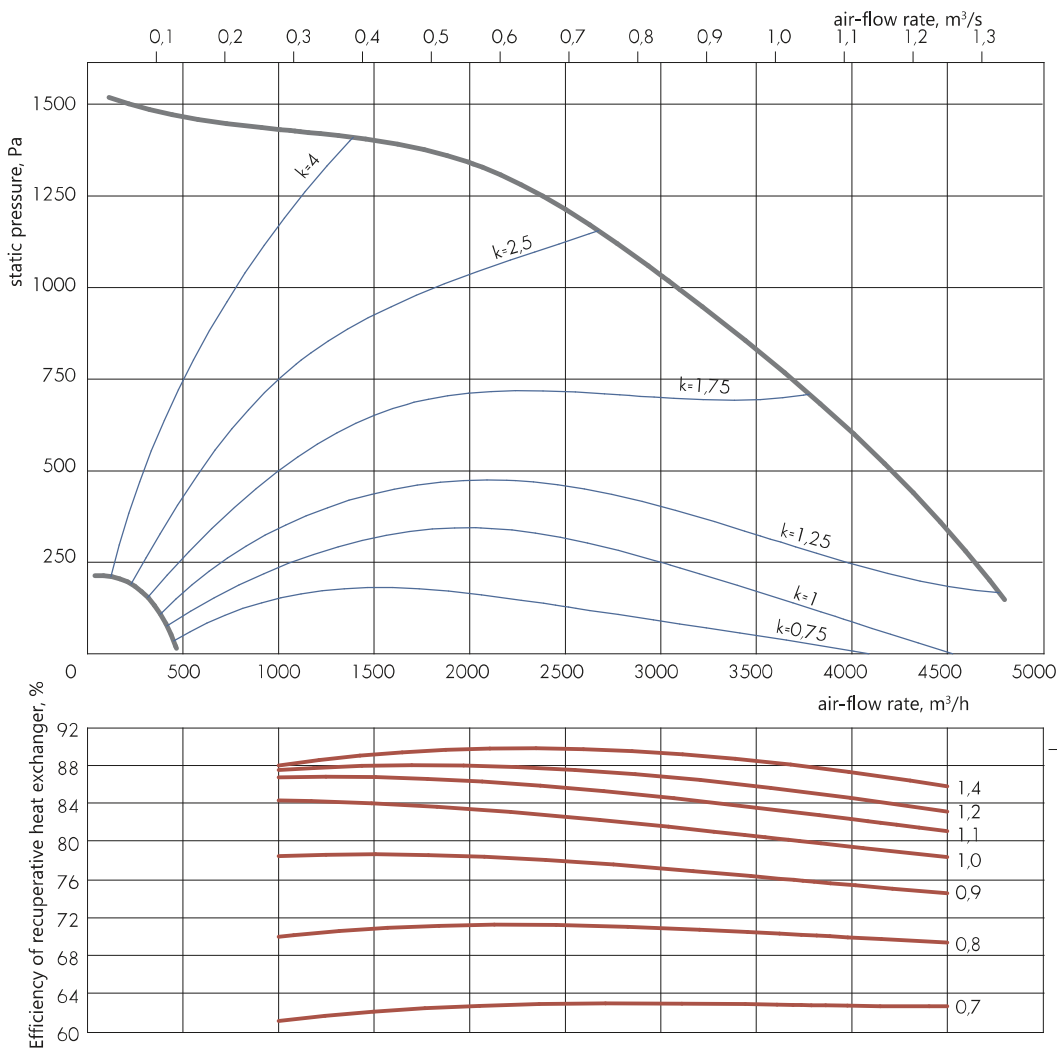

The temperature efficiency graph is shown at the same supply and exhaust air flow rates, and at the exhaust air temperature t = +20° C, relative humidity rh = 50%

AEROSMART-EC-301	Sound power level, dB								Total sound pressure level, dB(A)**
	Octave band mid-frequency, Hz*								
	63	125	250	500	1000	2000	4000	8000	
Input	57	58	63	60	51	51	49	43	61
Output	60	64	71	69	70	70	70	65	76
Surrounding	58	59	53	44	50	55	58	54	62

* At nominal flow rate and maximum fan speed.

** Total sound pressure level (not to be confused with power) at a distance of 3 meters.

An example of using the aerodynamic characteristic and temperature efficiency graph is given above.



AEROSMART-EC-300/301

MODULAR DESIGN

HORIZONTAL CONNECTION

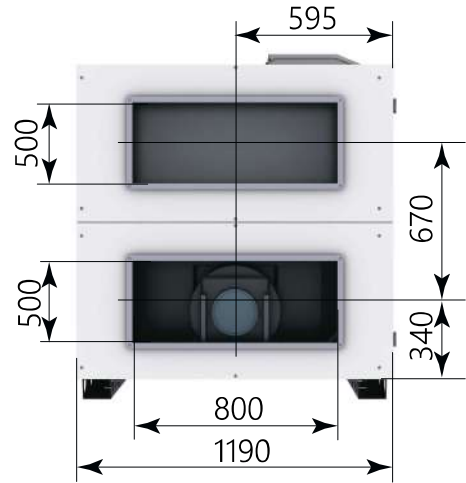
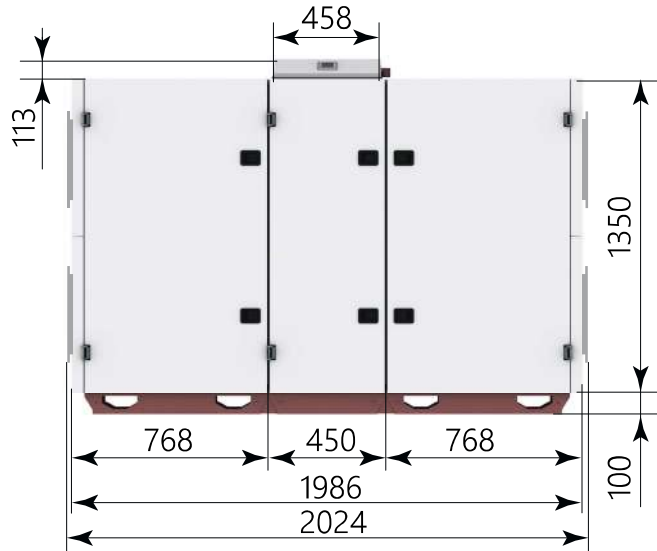

VERTICAL CONNECTION

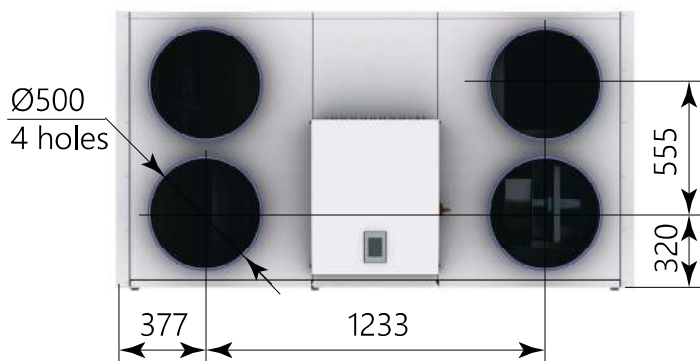
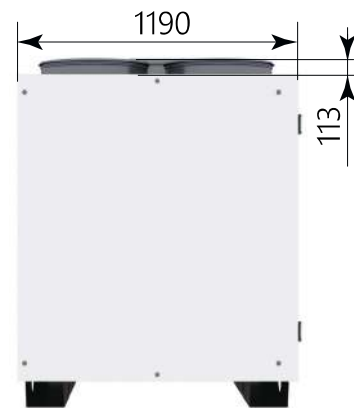
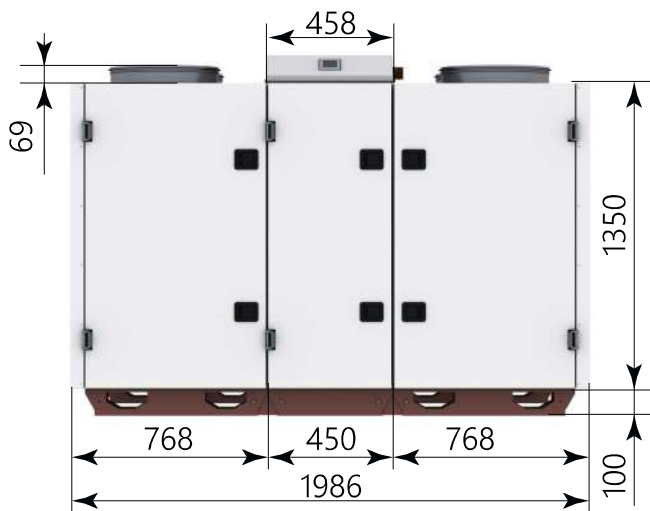



AEROSMART-EC-400

Parameter	VALUE
Nominal air-flow rate*, m ³ /h	4000
External static pressure*, Pa	810
Maximum air flow rate (at static pressure 200 Pa), m ³ /h	5590
Supply voltage	~3/ 380 V/ 50 Hz
Fan power (supply/exhaust), kW	1,9/1,9
Total electrical power of the AHU, kW	3,94
Filter (supply/exhaust)	M5/M5
Weight, kg, max	543

* The values are valid under normal conditions for both the supply and exhaust paths.

AERODYNAMIC CHARACTERISTICS

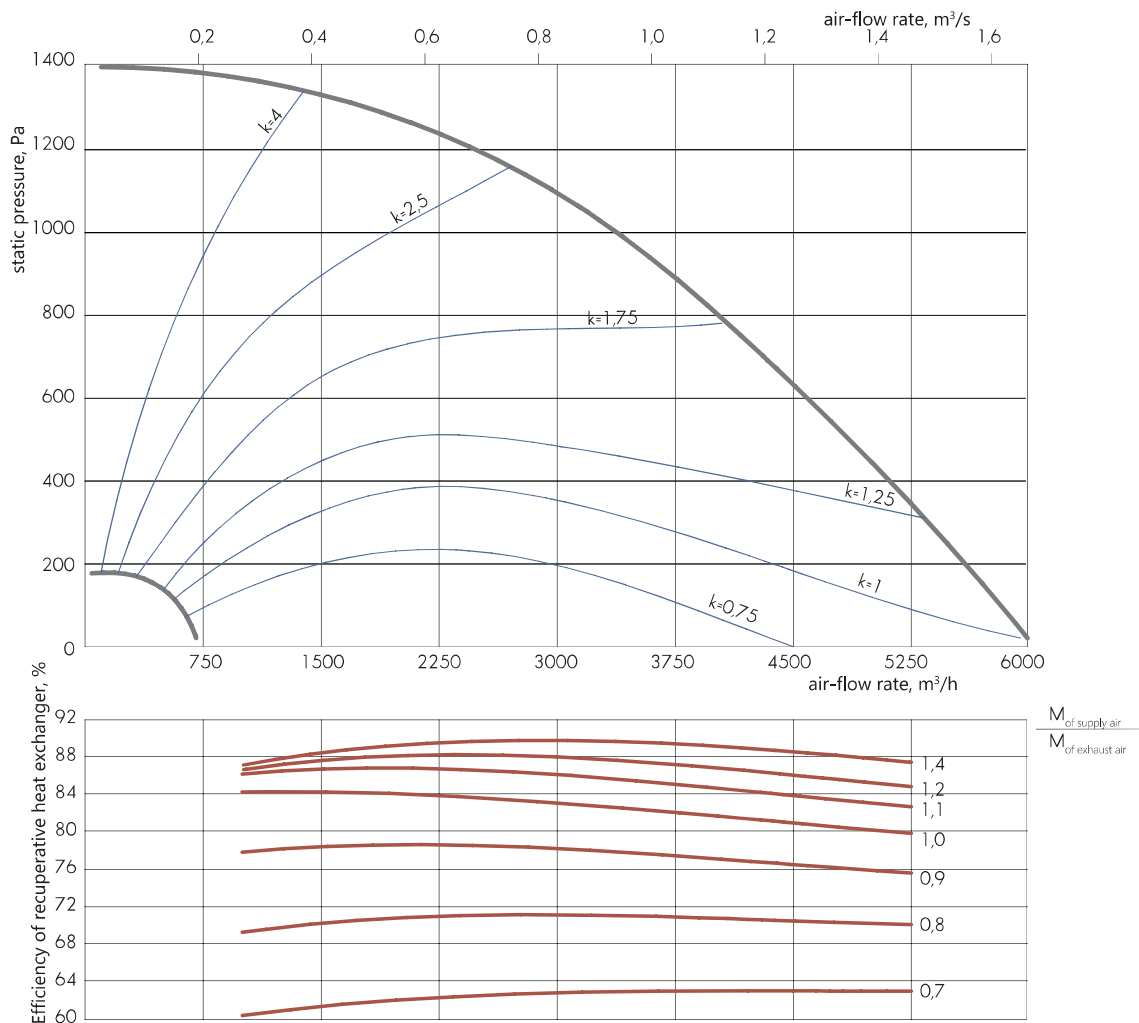

The temperature efficiency graph is shown at the same supply and exhaust air flow rates, and at the exhaust air temperature t = +20° C, relative humidity rh = 50%

AEROSMART-EC-400	Sound power level, dB								Total sound pressure level, dB(A)**
	Octave band mid-frequency, Hz*								
	63	125	250	500	1000	2000	4000	8000	
Input	57	55	62	60	52	50	47	40	60
Output	62	61	72	69	69	68	67	62	75
Surrounding	60	56	54	44	49	53	55	51	60

* At nominal flow rate and maximum fan speed.

** Total sound pressure level (not to be confused with power) at a distance of 3 meters.

An example of using the aerodynamic characteristic and temperature efficiency graph is given above.



AEROSMART-EC-401

Parameter	VALUE
Nominal air-flow rate*, m ³ /h	4000
External static pressure*, Pa	920
Maximum air flow rate (at static pressure 200 Pa), m ³ /h	6960
Supply voltage	~3/ 380 V/ 50 Hz
Fan power (supply/exhaust), kW	2,5/2,5
Total electrical power of the AHU, kW	5,14
Filter (supply/exhaust)	M5/M5
Weight, kg, max	545

* The values are valid under normal conditions for both the supply and exhaust paths.

AERODYNAMIC CHARACTERISTICS

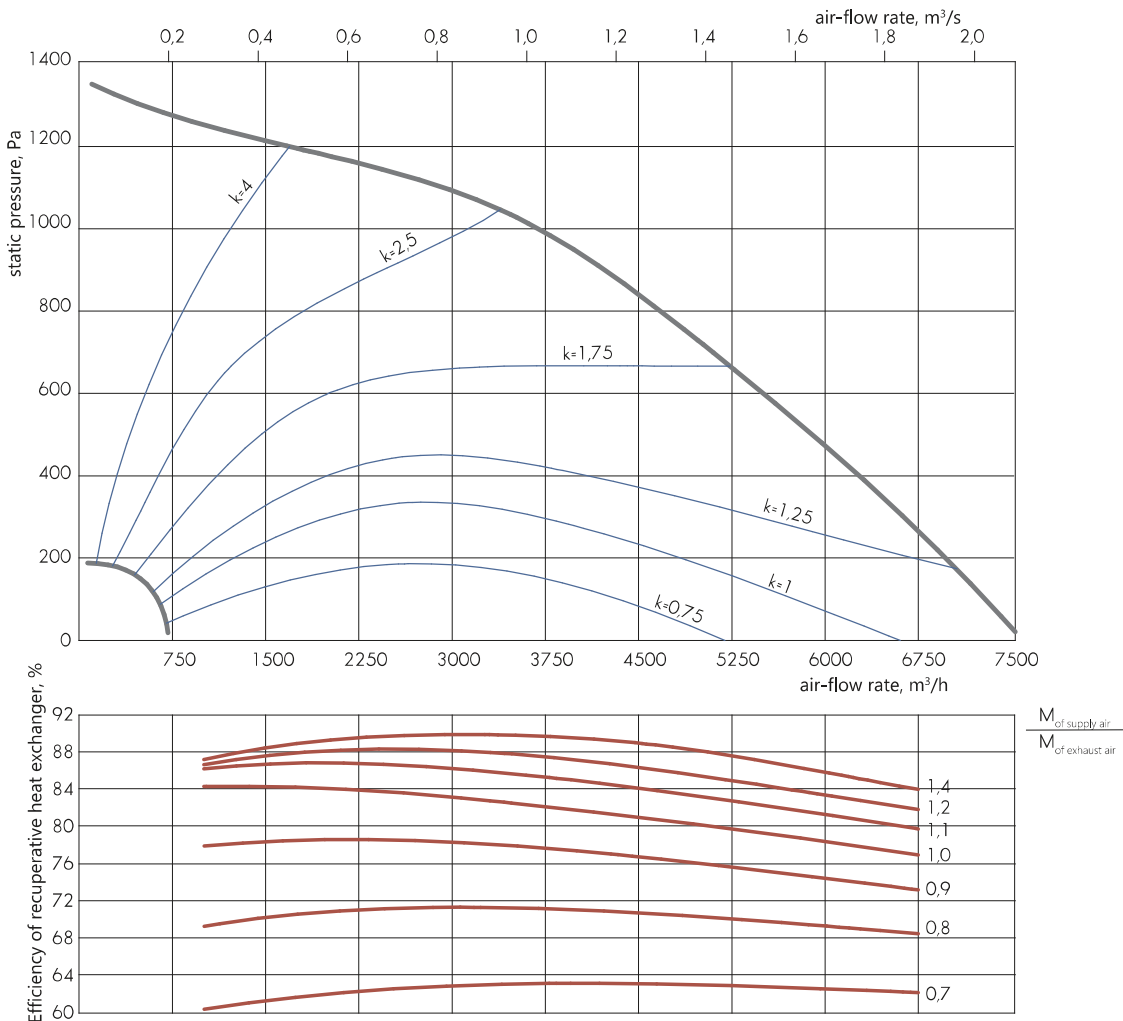

The temperature efficiency graph is shown at the same supply and exhaust air flow rates, and at the exhaust air temperature t = +20° C, relative humidity rh = 50%

AEROSMART-EC-401	Sound power level, dB								Total sound pressure level, dB(A)**
	Octave band mid-frequency, Hz*								
	63	125	250	500	1000	2000	4000	8000	
Input	60	71	70	61	54	52	46	41	64
Output	63	74	85	72	71	70	66	63	79
Surrounding	61	69	67	47	51	55	54	52	63

* At nominal flow rate and maximum fan speed.

** Total sound pressure level (not to be confused with power) at a distance of 3 meters.

AIR HANDLING UNITS

76

An example of using the aerodynamic characteristic and temperature efficiency graph is given above.

AEROSMART-EC-400/401

MODULAR DESIGN

HORIZONTAL CONNECTION

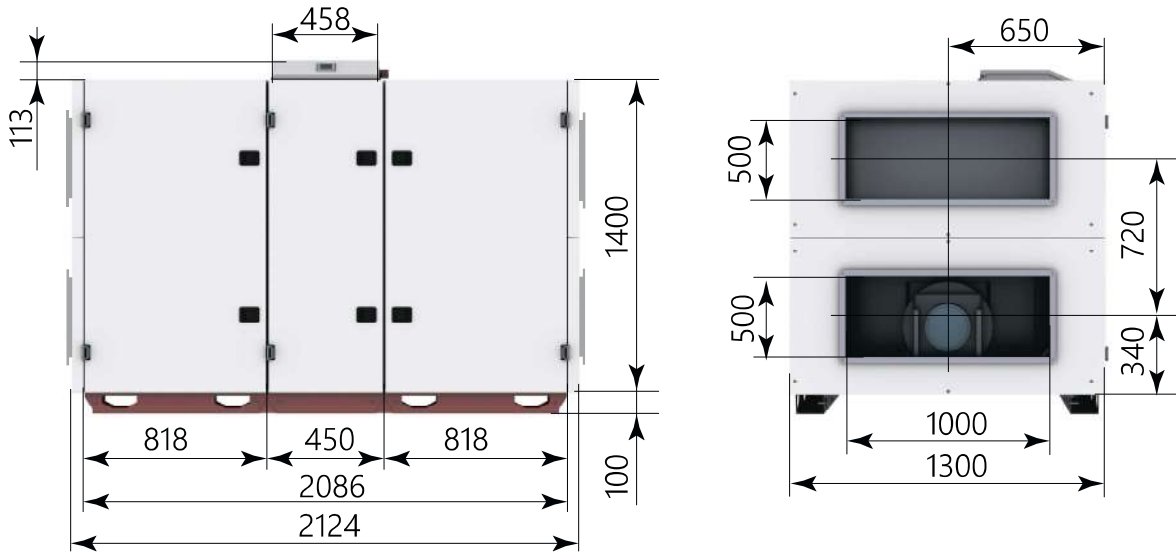

VERTICAL CONNECTION

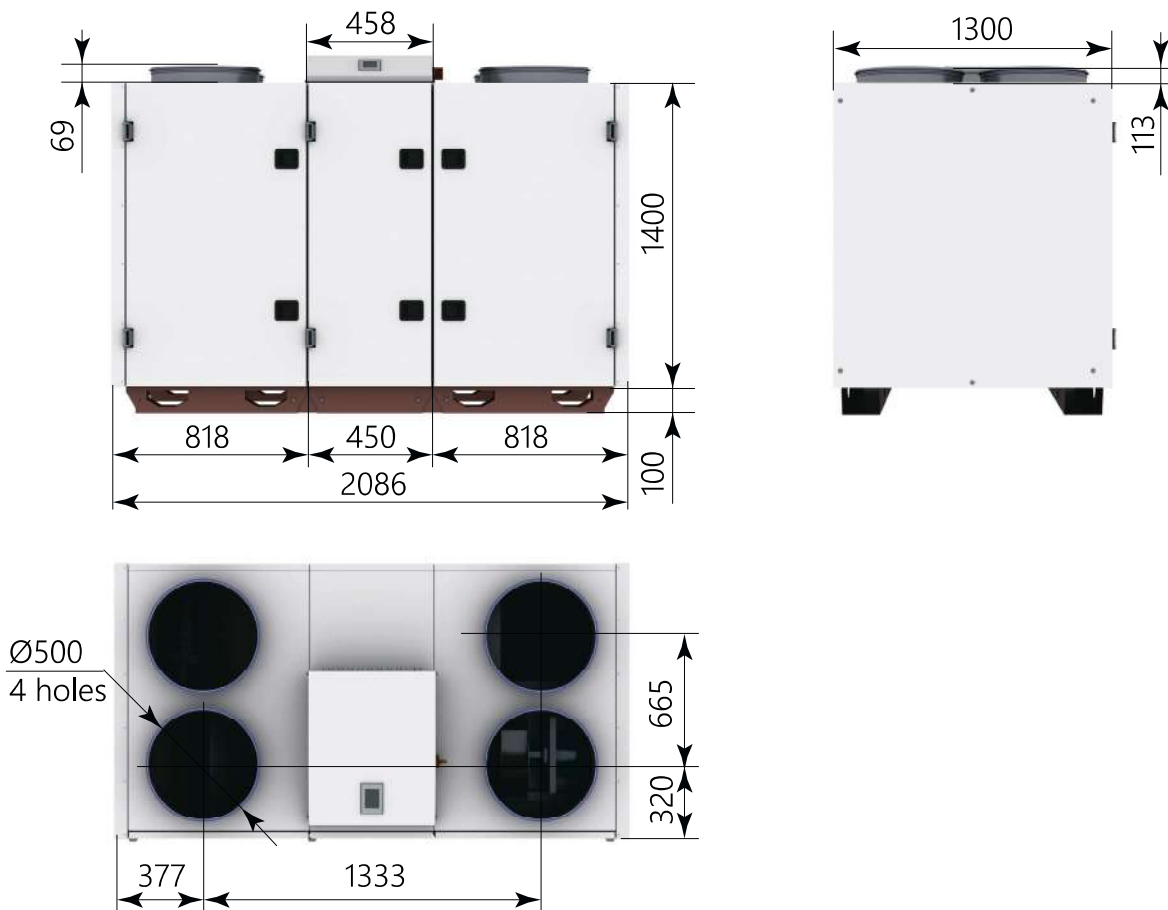

AEROSMART-EC-550

Parameter	VALUE
Nominal air-flow rate*, m ³ /h	5500
External static pressure*, Pa	790
Maximum air flow rate (at static pressure 200 Pa), m ³ /h	7870
Supply voltage	~3/ 380 V/ 50 Hz
Fan power (supply/exhaust), kW	2,5/2,5
Total electrical power of the AHU, kW	5,14
Filter (supply/exhaust)	M5/M5
Weight, kg, max	659

* The values are valid under normal conditions for both the supply and exhaust paths.

AERODYNAMIC CHARACTERISTICS

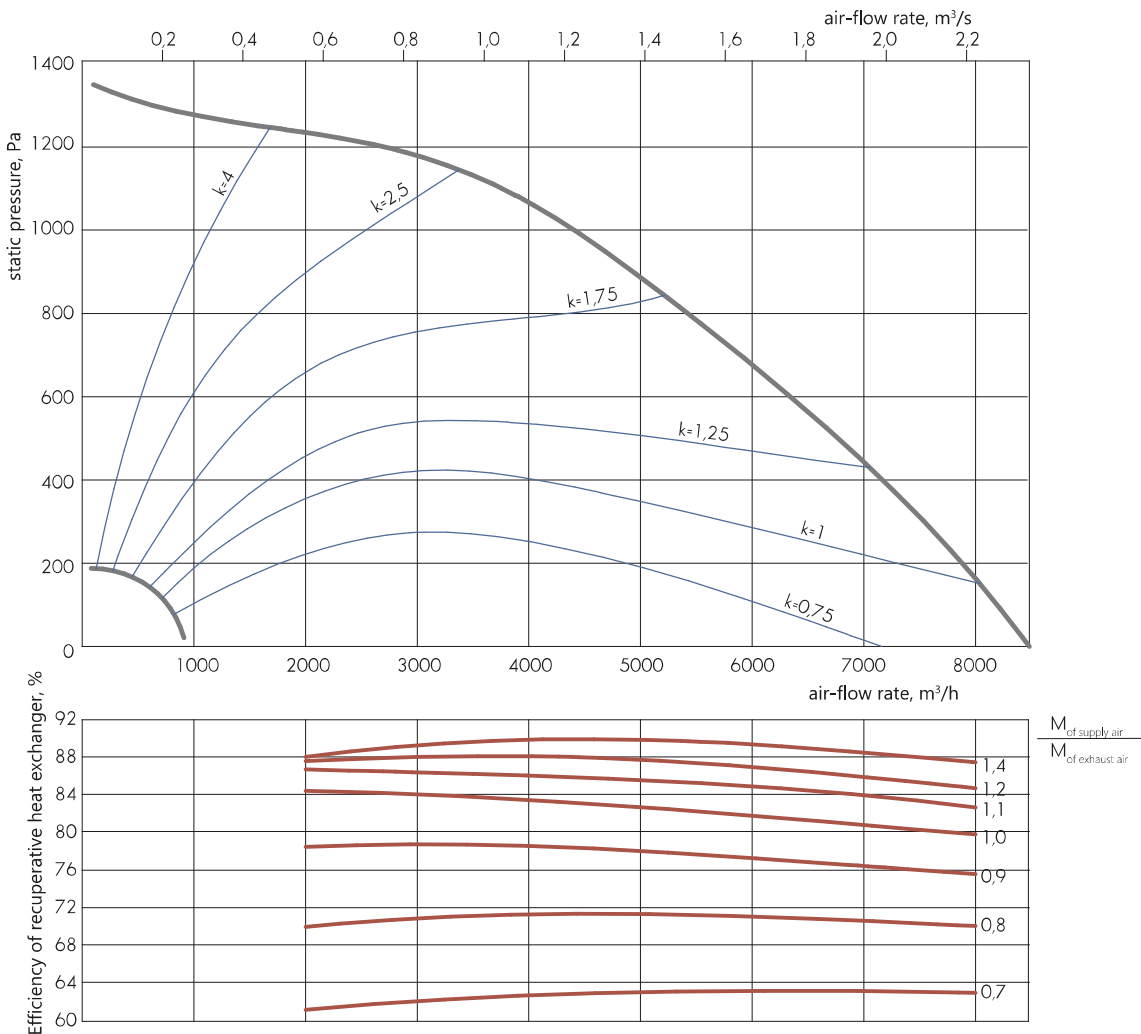

The temperature efficiency graph is shown at the same supply and exhaust air flow rates, and at the exhaust air temperature $t = +20^{\circ}\text{C}$, relative humidity $rh = 50\%$

AEROSMART-EC-550	Sound power level, dB								Total sound pressure level, dB(A)**
	Octave band mid-frequency, Hz*								
	63	125	250	500	1000	2000	4000	8000	
Input	57	63	64	58	52	51	48	39	60
Output	62	68	73	70	69	69	66	62	75
Surrounding	60	63	55	45	49	54	54	51	60

* At nominal flow rate and maximum fan speed.

** Total sound pressure level (not to be confused with power) at a distance of 3 meters.

An example of using the aerodynamic characteristic and temperature efficiency graph is given above.



AEROSMART-EC-551

Parameter	VALUE
Nominal air-flow rate*, m ³ /h	5500
External static pressure*, Pa	1135
Maximum air flow rate (at static pressure 200 Pa), m ³ /h	9020
Supply voltage	~3/ 380 V/ 50 Hz
Fan power (supply/exhaust), kW	3,35/3,35
Total electrical power of the AHU, kW	6,84
Filter (supply/exhaust)	M5/M5
Weight, kg, max	665

* The values are valid under normal conditions for both the supply and exhaust paths.

AERODYNAMIC CHARACTERISTICS

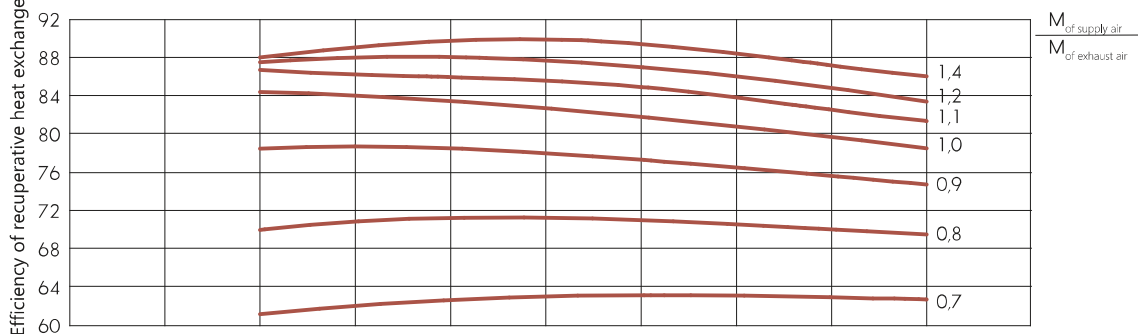
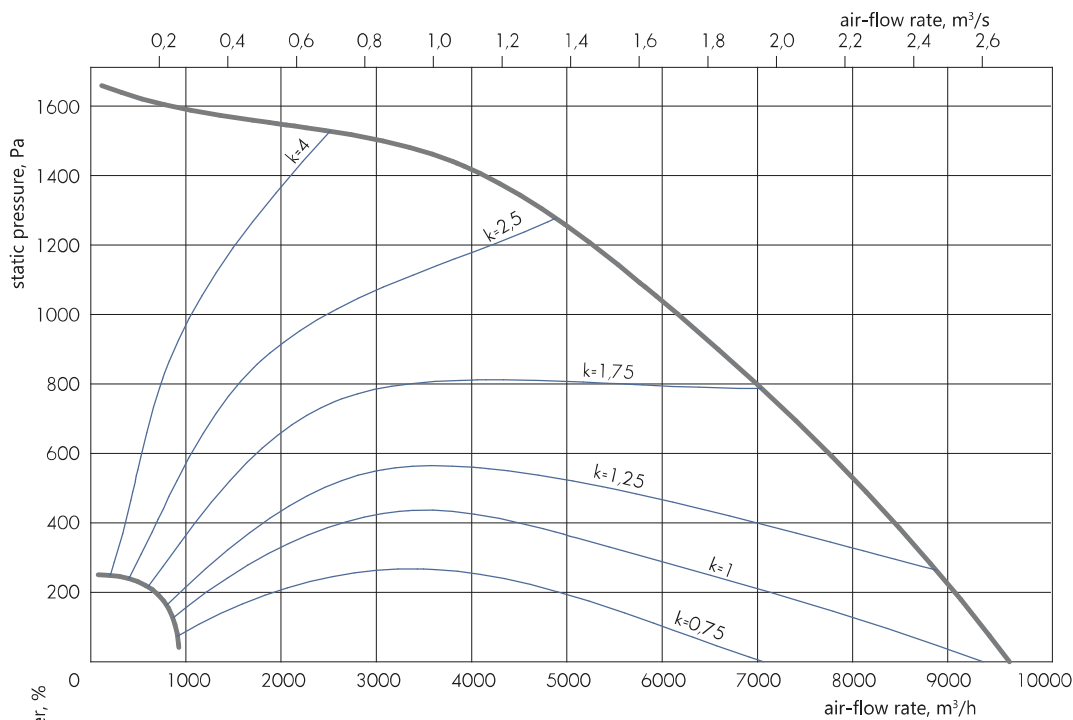

The temperature efficiency graph is shown at the same supply and exhaust air flow rates, and at the exhaust air temperature $t = +20^{\circ}\text{C}$, relative humidity $rh = 50\%$

AEROSMART-EC-551	Sound power level, dB								Total sound pressure level, dB(A)**
	Octave band mid-frequency, Hz*								
	63	125	250	500	1000	2000	4000	8000	
Input	63	64	69	63	57	53	50	45	65
Output	68	69	79	75	77	74	73	66	81
Surrounding	66	64	61	50	57	59	61	55	66

* At nominal flow rate and maximum fan speed.

** Total sound pressure level (not to be confused with power) at a distance of 3 meters.

An example of using the aerodynamic characteristic and temperature efficiency graph is given above.



AEROSMART-EC-550/551

MODULAR DESIGN

HORIZONTAL CONNECTION

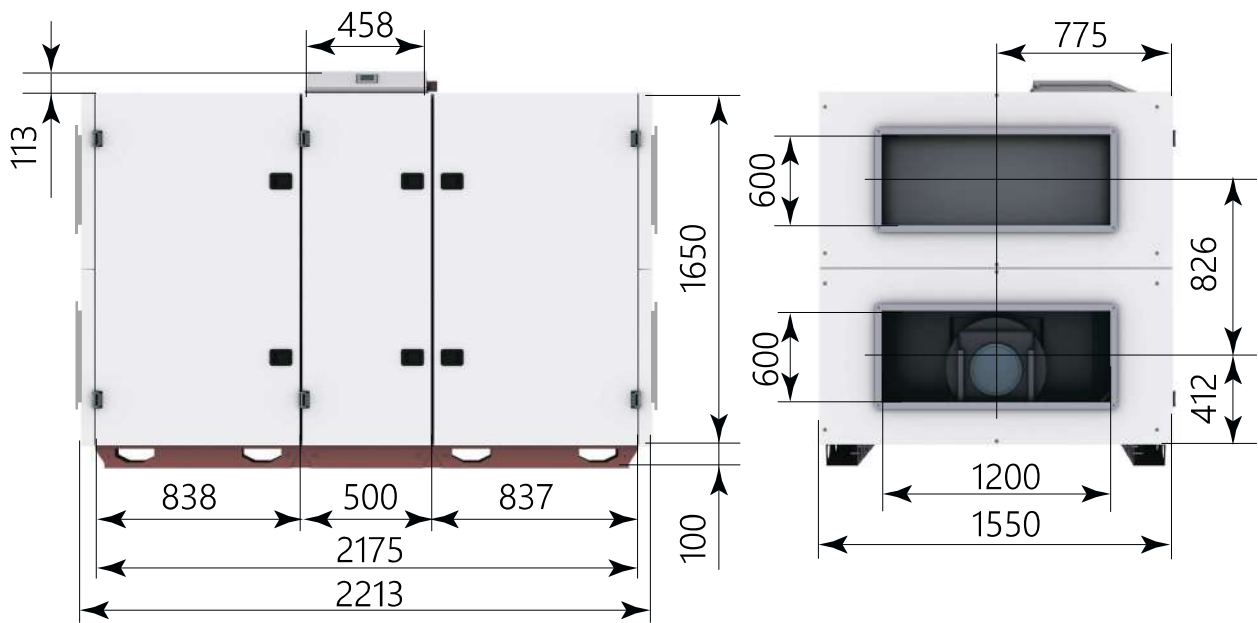



AEROSMART-EC-650

Parameter	VALUE
Nominal air-flow rate*, m ³ /h	6500
External static pressure*, Pa	830
Maximum air flow rate (at static pressure 200 Pa), m ³ /h	9540
Supply voltage	~3/ 380 V/ 50 Hz
Fan power (supply/exhaust), kW	2,9/2,9
Total electrical power of the AHU, kW	5,94
Filter (supply/exhaust)	M5/M5
Weight, kg, max	784

* The values are valid under normal conditions for both the supply and exhaust paths.

AERODYNAMIC CHARACTERISTICS

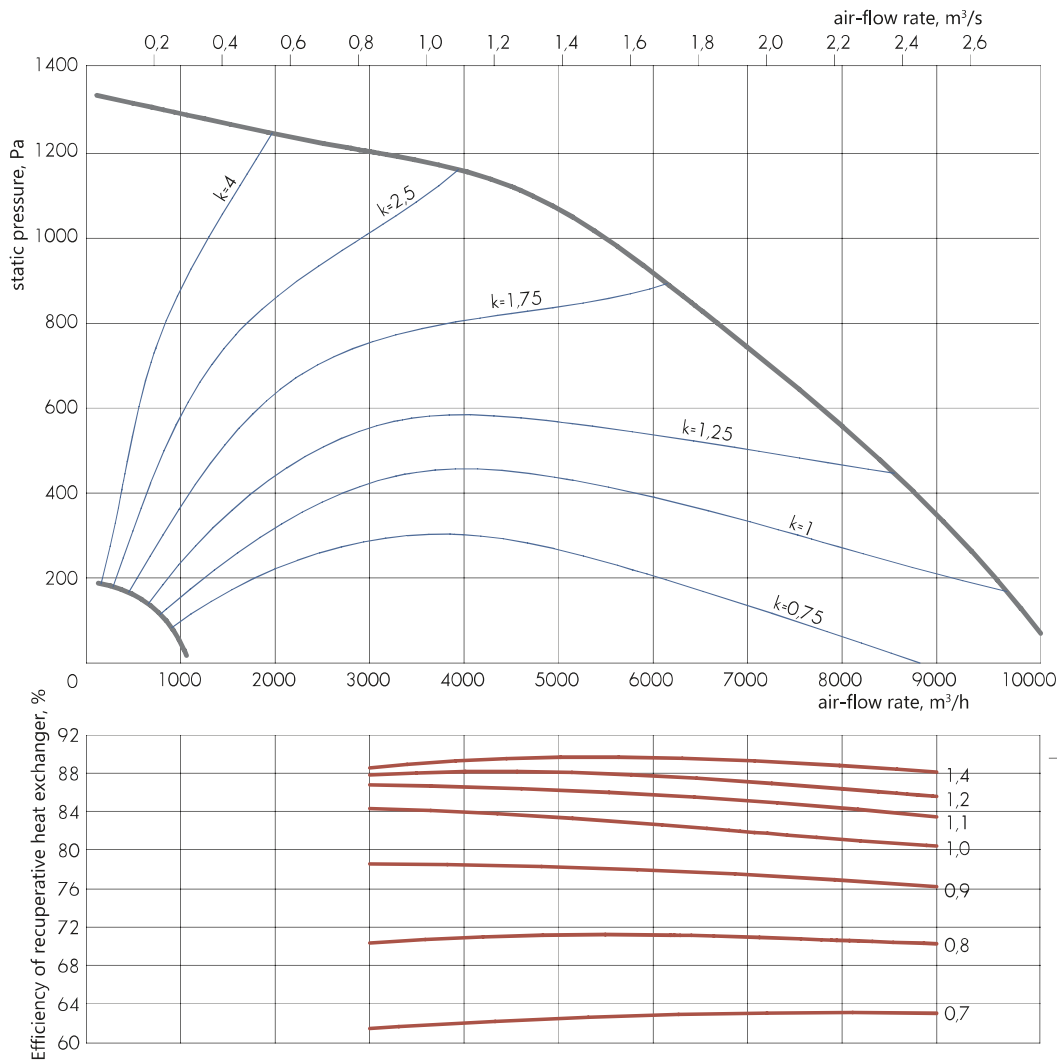

The temperature efficiency graph is shown at the same supply and exhaust air flow rates, and at the exhaust air temperature $t = +20^{\circ}\text{C}$, relative humidity $rh = 50\%$

AEROSMART-EC-650	Sound power level, dB								Total sound pressure level, dB(A)**
	Octave band mid-frequency, Hz*								
	63	125	250	500	1000	2000	4000	8000	
Input	60	63	59	57	54	51	48	40	60
Output	63	67	69	70	71	69	66	61	75
Surrounding	61	62	51	45	51	54	54	50	60

* At nominal flow rate and maximum fan speed.

** Total sound pressure level (not to be confused with power) at a distance of 3 meters.

An example of using the aerodynamic characteristic and temperature efficiency graph is given above.



AEROSMART-EC-651

Parameter	VALUE
Nominal air-flow rate*, m ³ /h	6500
External static pressure*, Pa	920
Maximum air flow rate (at static pressure 200 Pa), m ³ /h	11150
Supply voltage	~3/ 380 V/ 50 Hz
Fan power (supply/exhaust), kW	3,45/3,45
Total electrical power of the AHU, kW	7,04
Filter (supply/exhaust)	M5/M5
Weight, kg, max	785

* The values are valid under normal conditions for both the supply and exhaust paths.

AERODYNAMIC CHARACTERISTICS

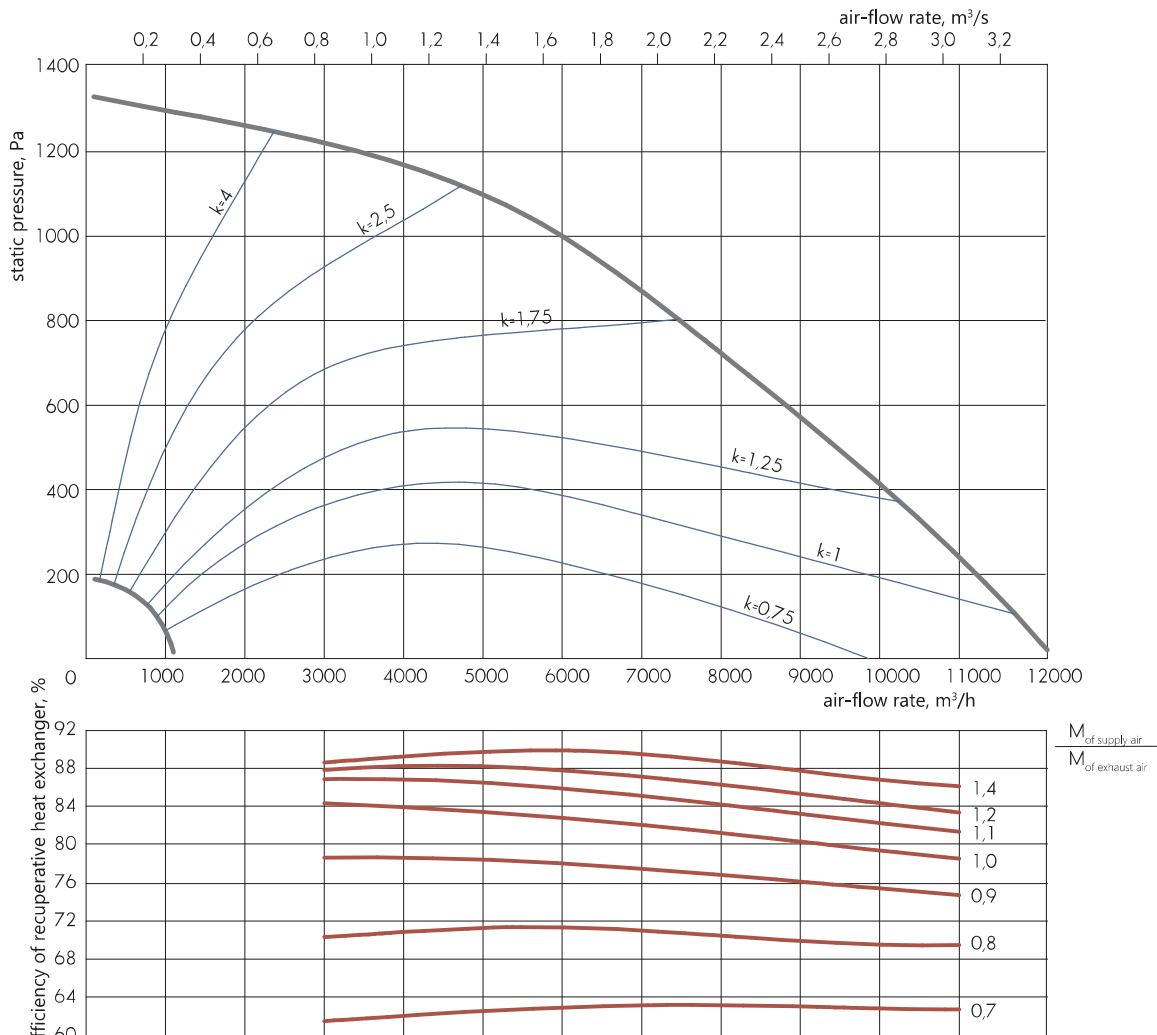

The temperature efficiency graph is shown at the same supply and exhaust air flow rates, and at the exhaust air temperature t = +20° C, relative humidity rh = 50%

AEROSMART-EC-651	Sound power level, dB								Total sound pressure level, dB(A)**
	Octave band mid-frequency, Hz*								
	63	125	250	500	1000	2000	4000	8000	
Input	61	72	61	58	56	52	48	42	62
Output	65	78	71	71	73	71	66	63	77
Surrounding	63	73	53	46	53	56	54	52	62

* At nominal flow rate and maximum fan speed.

** Total sound pressure level (not to be confused with power) at a distance of 3 meters.

AEROSMART-EC-650/651

MODULAR DESIGN

HORIZONTAL CONNECTION

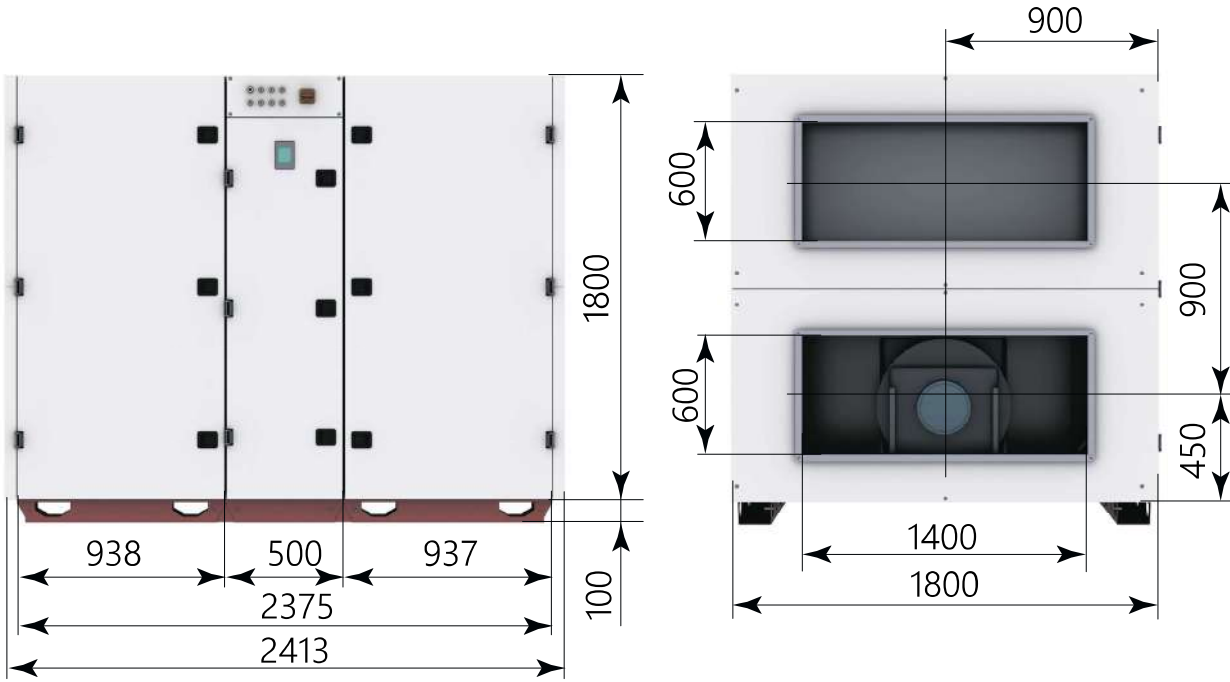



AEROSMART-EC-850

Parameter	VALUE
Nominal air-flow rate*, m ³ /h	8500
External static pressure*, Pa	665
Maximum air flow rate (at static pressure 200 Pa), m ³ /h	12600
Supply voltage	~3/ 380 V/ 50 Hz
Fan power (supply/exhaust), kW	3,3/3,3
Total electrical power of the AHU, kW	6,74
Filter (supply/exhaust)	M5/M5
Weight, kg, max	947

* The values are valid under normal conditions for both the supply and exhaust paths.

AERODYNAMIC CHARACTERISTICS

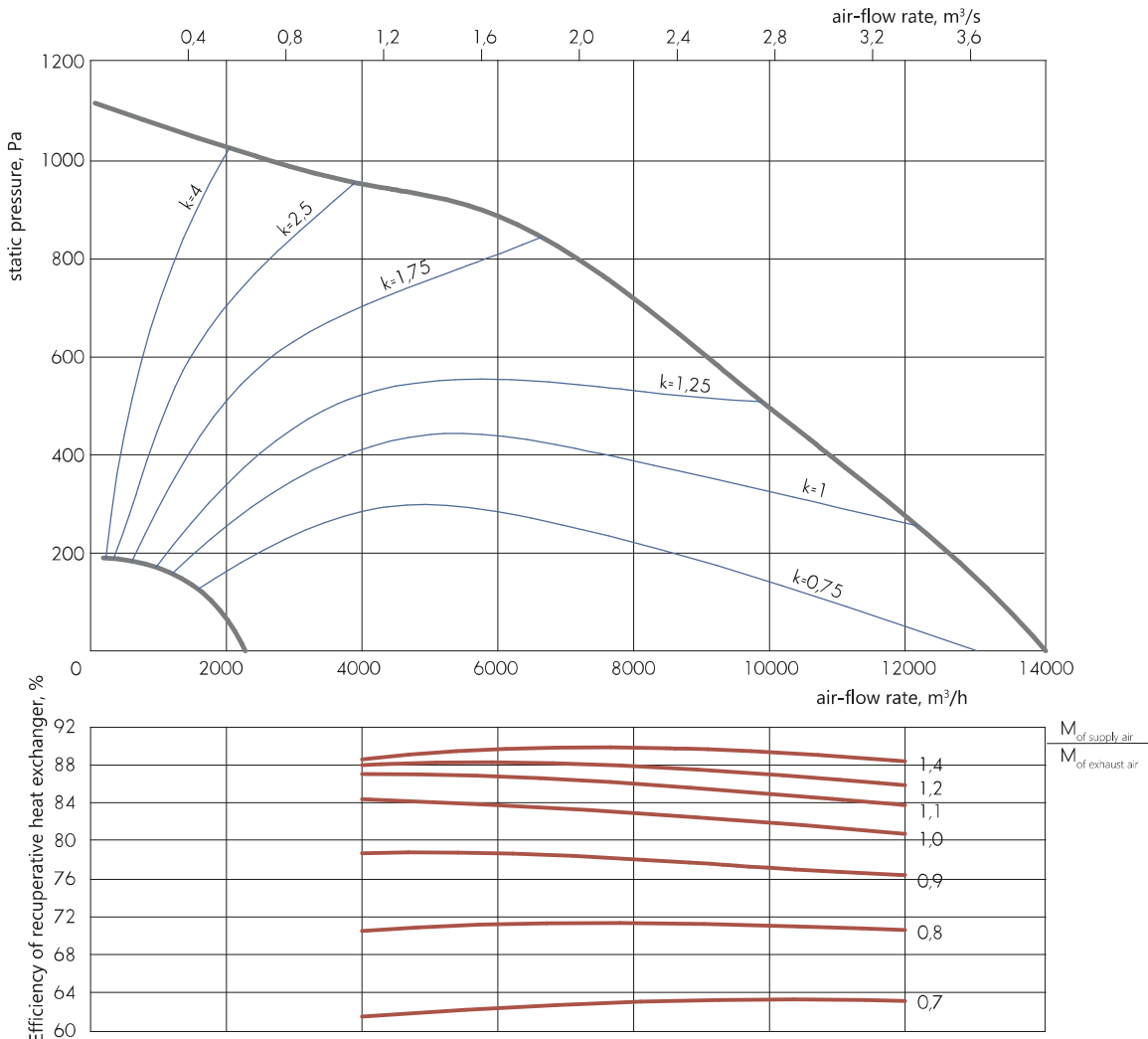

The temperature efficiency graph is shown at the same supply and exhaust air flow rates, and at the exhaust air temperature t = +20° C, relative humidity rh = 50%

AEROSMART-EC-850	Sound power level, dB								Total sound pressure level, dB(A)**
	Octave band mid-frequency, Hz*								
	63	125	250	500	1000	2000	4000	8000	
Input	54	62	54	52	56	49	45	39	58
Output	58	70	66	67	70	66	63	60	73
Surrounding	56	65	48	42	50	51	51	49	58

* At nominal flow rate and maximum fan speed.

** Total sound pressure level (not to be confused with power) at a distance of 3 meters.

84 AIR HANDLING UNITS

An example of using the aerodynamic characteristic and temperature efficiency graph is given above.





AEROSMART-EC-851

Parameter	VALUE
Nominal air-flow rate*, m ³ /h	8500
External static pressure*, Pa	1050
Maximum air flow rate (at static pressure 200 Pa), m ³ /h	15550
Supply voltage	~3/ 380 V/ 50 Hz
Fan power (supply/exhaust), kW	5/5
Total electrical power of the AHU, kW	10,14
Filter (supply/exhaust)	M5/M5
Weight, kg, max	955

* The values are valid under normal conditions for both the supply and exhaust paths.

AERODYNAMIC CHARACTERISTICS

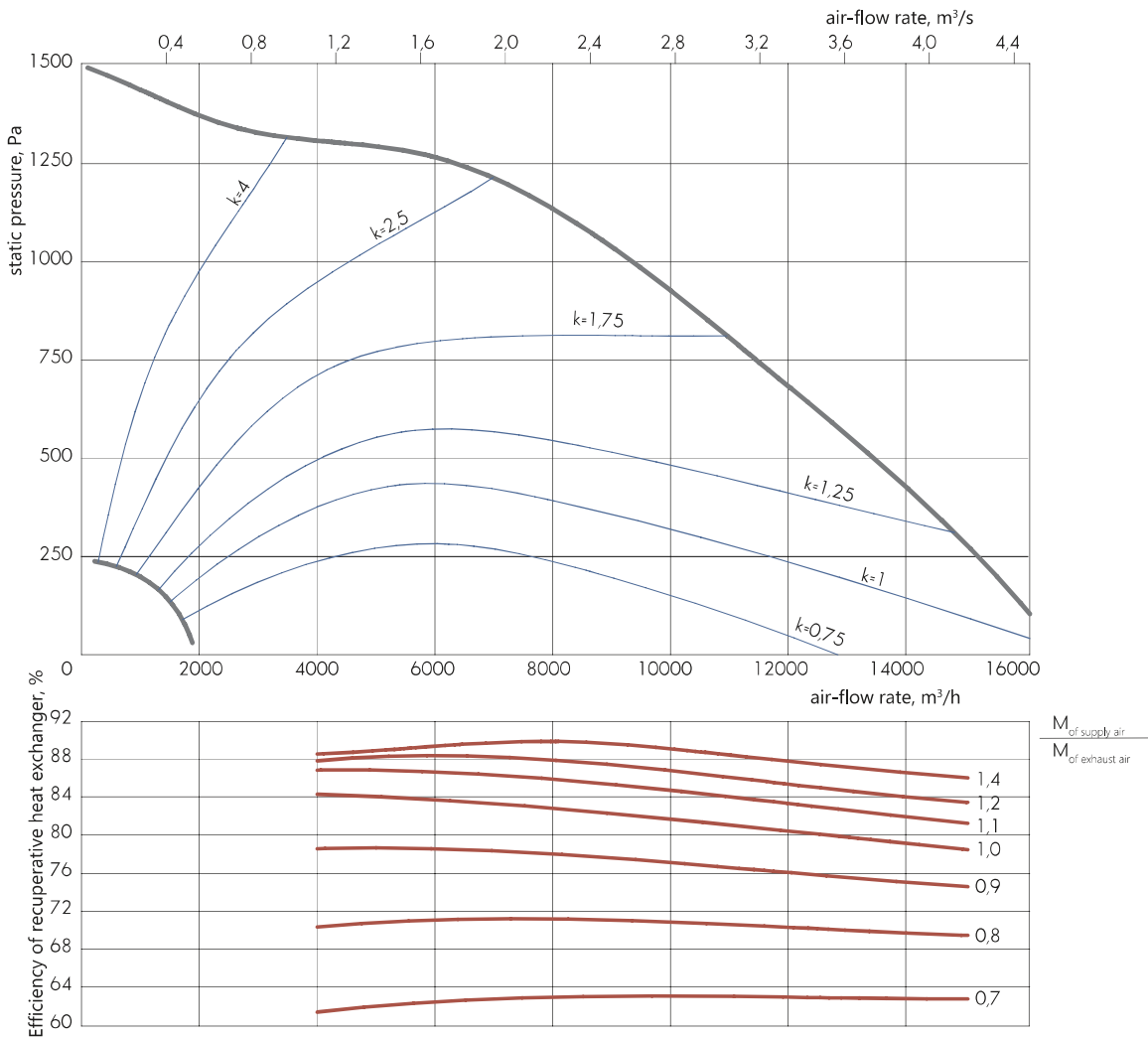

The temperature efficiency graph is shown at the same supply and exhaust air flow rates, and at the exhaust air temperature t = +20° C, relative humidity rh = 50%

AEROSMART-EC-851	Sound power level, dB								Total sound pressure level, dB(A)**
	Octave band mid-frequency, Hz*								
	63	125	250	500	1000	2000	4000	8000	
Input	62	78	63	59	58	54	48	44	65
Output	67	84	73	74	77	73	67	65	80
Surrounding	65	79	55	49	57	58	55	54	66

* At nominal flow rate and maximum fan speed.

** Total sound pressure level (not to be confused with power) at a distance of 3 meters.

An example of using the aerodynamic characteristic and temperature efficiency graph is given above.



AEROSMART-EC-850/851

MODULAR DESIGN

HORIZONTAL CONNECTION

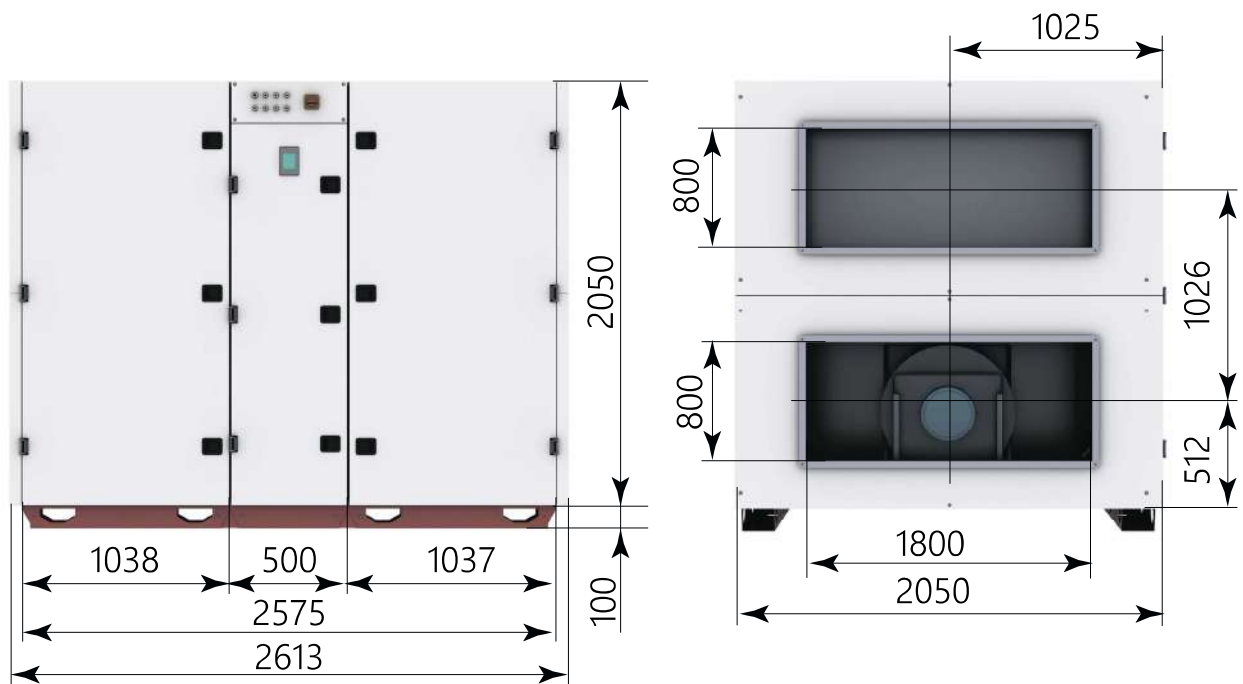



AEROSMART-EC-1050

Parameter	VALUE
Nominal air-flow rate*, m ³ /h	10500
External static pressure*, Pa	930
Maximum air flow rate (at static pressure 200 Pa), m ³ /h	16300
Supply voltage	~3/ 380 V/ 50 Hz
Fan power (supply/exhaust), kW	5/5
Total electrical power of the AHU, kW	10,14
Filter (supply/exhaust)	M5/M5
Weight, kg, max	1090

* The values are valid under normal conditions for both the supply and exhaust paths.

AERODYNAMIC CHARACTERISTICS

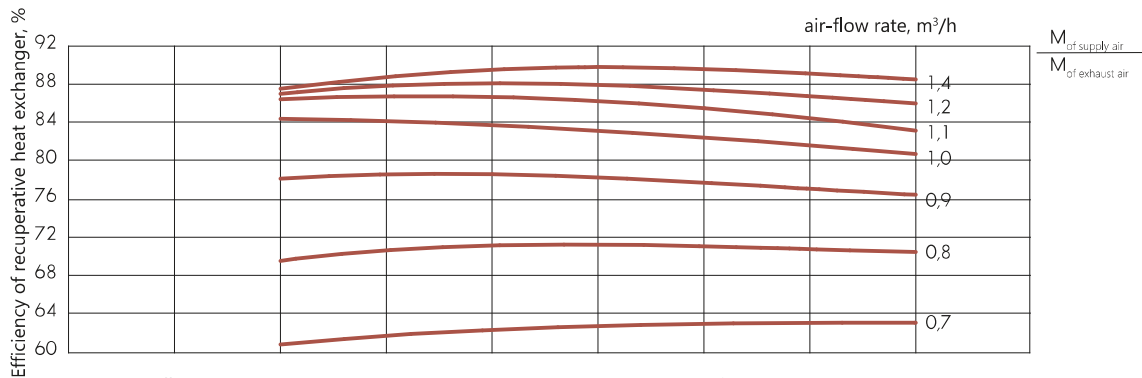
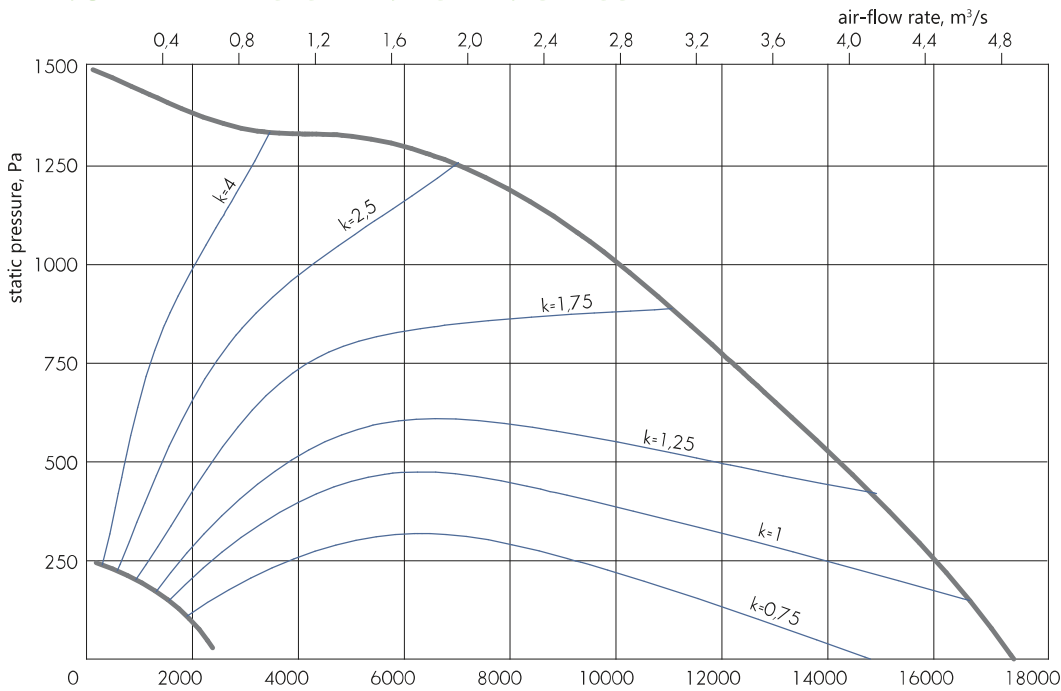

The temperature efficiency graph is shown at the same supply and exhaust air flow rates, and at the exhaust air temperature $t = +20^\circ \text{C}$, relative humidity $rh = 50\%$

AEROSMART-EC-1050	Sound power level, dB								Total sound pressure level, dB(A)**
	Octave band mid-frequency, Hz*								
	63	125	250	500	1000	2000	4000	8000	
Input	56	67	58	55	56	53	49	43	61
Output	64	73	69	70	76	71	67	64	79
Surrounding	62	68	51	45	56	56	55	53	62

* At nominal flow rate and maximum fan speed.

** Total sound pressure level (not to be confused with power) at a distance of 3 meters.

An example of using the aerodynamic characteristic and temperature efficiency graph is given above.



AEROSMART-EC-1051

Parameter	VALUE
Nominal air-flow rate*, m ³ /h	10500
External static pressure*, Pa	900
Maximum air flow rate (at static pressure 200 Pa), m ³ /h	18550
Supply voltage	~3/ 380 V/ 50 Hz
Fan power (supply/exhaust), kW	6,75/6,75
Total electrical power of the AHU, kW	13,64
Filter (supply/exhaust)	M5/M5
Weight, kg, max	1185

* The values are valid under normal conditions for both the supply and exhaust paths.

AERODYNAMIC CHARACTERISTICS

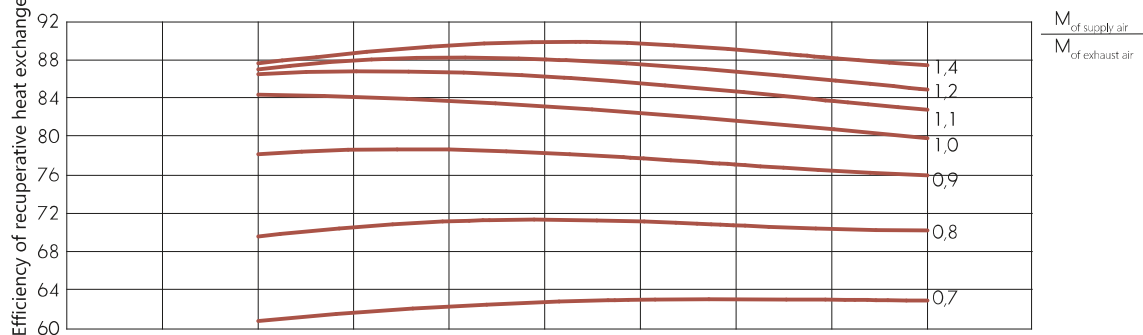
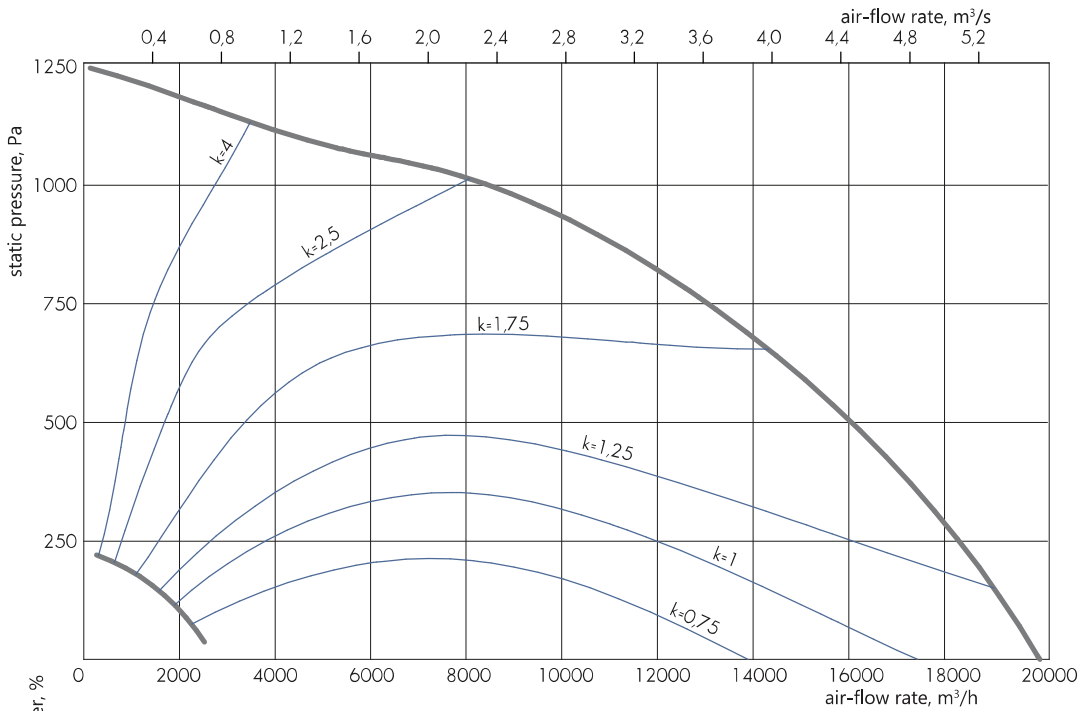

The temperature efficiency graph is shown at the same supply and exhaust air flow rates, and at the exhaust air temperature $t = +20^{\circ}\text{C}$, relative humidity $rh = 50\%$

AEROSMART-EC-1051	Sound power level, dB								Total sound pressure level, dB(A)**
	Octave band mid-frequency, Hz*								
	63	125	250	500	1000	2000	4000	8000	
Input	72	72	66	62	61	56	50	47	66
Output	77	83	86	78	78	74	68	66	83
Surrounding	75	78	68	53	58	59	56	55	67

* At nominal flow rate and maximum fan speed.

** Total sound pressure level (not to be confused with power) at a distance of 3 meters.

AIR HANDLING UNITS

88

An example of using the aerodynamic characteristic and temperature efficiency graph is given above.

AEROSMART-EC-1050/1051

MODULAR DESIGN

HORIZONTAL CONNECTION

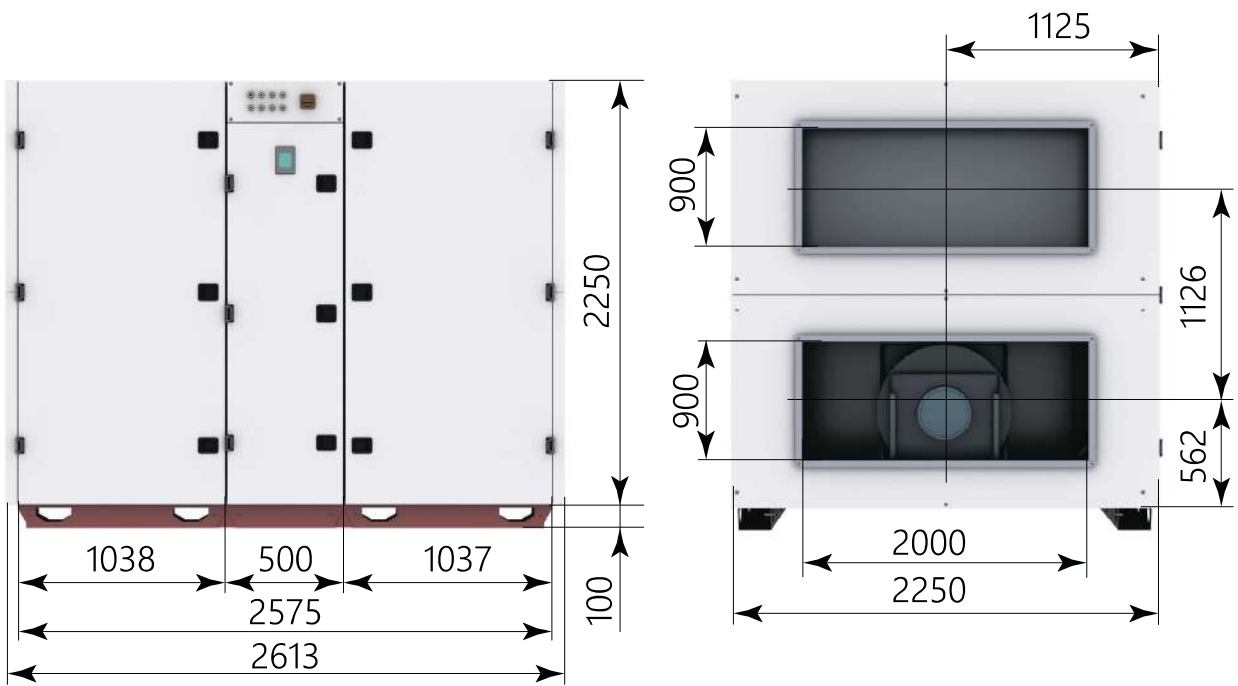

AUTOMATIC CONTROL SYSTEM



The automatic control system is used for power supply and automated control of AEROSMART-EC air handling units. Intelligent software allows for the implementation of a wide range of functions of the unit and provides reliable control and monitoring algorithms.

The automatic control system includes a controller, an instrumentation equipment, a control panel and other control and protection elements of the AHU.

The controller and start-up and protective equipment, as well as some instrumentation equipment, are placed either on the casing or inside the unit casing, depending on the standard size.

All monitoring and control devices and instruments that are located inside the unit are already connected to the controller. Connection of additional control facilities, as well as instrumentation equipment that are supposed to be installed outside the AHU, is made at the installation site through special cable glands in the SAU cabinet.

AEROSMART-EC air handling units are manufactured on the plug & play principle, which, combined with built-in intelligent automation, reduces installation costs, and also facilitates the start-up of units and their commissioning.

The units are controlled by a remote control, which is always included in the delivery package. The control panel features a modern design and a color touch screen, which allows it to be conveniently integrated into the interior of any room.

The built-in automation system ensures not only optimal operation control, but also safe operation of the AHU.

ОСНОВНІ ФУНКЦІЇ

Maintaining the air temperature	Automatic maintenance of air temperature both by the temperature sensor inside the duct and by the air temperature sensor in the serviced room.
Starting the unit via an external potential-free contact	Easy implementation of remote activation of the AHU from any external device, sensor or just a switch
Built-in protocols for integration into the building management system	Built-in Modbus RTU & TCP/IP protocols with a typical set of variables for integration into a SCADA system or management via an OPC server.
Built-in clock and operation schedule settings	It is possible to set up both weekly operating modes and separate settings for calendar periods (for example, holidays).
Maintaining constant air flow	The air flow in the system is maintained by a built-in airflow measuring unit in the supply (exhaust) fan section and allows for significant energy savings by providing the required amount of supplied air.
Maintaining constant pressure	When an additional differential pressure sensor is connected, a constant overpressure or underpressure is maintained in the serviced room.
Air quality maintenance function	When the air quality sensor is connected, the air performance control mode is implemented with a decrease in energy consumption, when the need for fresh air is reduced.
Filter clogging monitoring with variable air capacity	Regardless of the current air capacity, the degree of clogging of air filters is determined by the current air flow rate. This provides diagnostics of the filter condition even when the air capacity is reduced.
Heat recovery efficiency management	A rotary heat recovery unit with a stepper motor drive provides a controlled level of heat recovery depending on the difference between the temperature of the outdoor and exhaust air; the serviceability of the heat recovery unit and the integrity of the rotor drive belt are monitored.
Protection of rotary heat exchanger from icing	Constant monitoring of the temperature of the air discharged to the outside and calculating the efficiency of heat recovery allow maintaining the maximum level of energy saving, preventing icing of the rotor.
Summer night cooling mode	When the outside air temperature drops to the required value at night, the unit is set to turn on to cool the room using the cool outside air.
Heat exchanger protection	When the liquid air heater module is connected, the heat exchanger protection via the return water temperature sensor and capillary thermostat is activated.
Electric heater protection	When an external electric heater is connected, overheating protection is activated and an algorithm for blowing it when the unit is turned off is implemented.
Air valve control	If the unit is supplied with external air valves, terminals for connecting air valve drives with a control voltage of 24 V are provided, and terminals for connecting the perimeter heating of the valve are provided.
Fire mode	Blocking the operation of the unit with a fire alarm system and a built-in fire alarm mode when the exhaust air temperature rises.
Alarm log	Alarms and system messages are recorded in the event log and can be viewed both on the control panel and via remote connection.

ADDITIONAL EQUIPMENT

The additional equipment of the AEROSTART-EC-CF and AEROSTART-EC-DX units is designed for installation outside the unit itself on the corresponding sections of air ducts when installing the unit indoors.

UNIVERSAL DUCT AIR VALVE



C-KVK-250-0

- universal air valve for round ducts
- size (for round connection section)
- drive type (electric drive type, 0 - to use with electric drive, HD - manual drive)

NOTE: for universal model designation of electric drive, see Reference information.

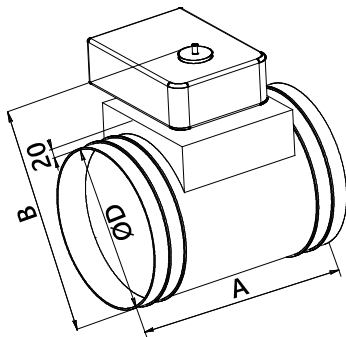

- designed to regulate the flow rate of supply and exhaust air in ducted ventilation and air conditioning systems;
- can be used for recirculating air;
- it is used for sealing the internal volume of ventilation networks;
- processed air must be treated and free of solid, fibrous, sticky or aggressive impurities;
- permissible content of dust and solid impurities not more than 0.1 g/m³;
- permissible temperature of the moved air is from -30° C to +50° C

The valves feature a round cross-section and a round casing with a blade installed inside. This design ensures a proportional dependence of the air flow through the valve on the blade pitch angle.

The structural elements of the valve are made of galvanized steel.

The blade is equipped with a rubber seal around the perimeter.

The following are used as actuators:

- manual drive for local manual operation;
- electric drive for remote control of the valve.

For air valves, open-closed drives are used either with a smoothly adjusted spring return, or two-position 220 V or 24 V. Universal model designation of the drive is given for all air valves.

The valve remains operational regardless of its spatial orientation.

ADDITIONAL EQUIPMENT

92

STANDARD SIZE	Type and standard size of the AHU	Dimensions, mm					Weight without drive, kg, max
		A	B	D	"open-closed"	spring return	
C-KVK-100	AEROSTART-EC-CF-250-LITE	200	215	100	M 220 (24)	F 220 (24)	0,65
C-KVK-160	AEROSTART-EC-CF-250	200	215	100			0,65
C-KVK-200	AEROSTART-EC-CF-550	200	363	250			1,85
C-KVK-250	AEROSTART-EC-DX-550	200	363	250			1,85
C-KVK-315	AEROSTART-EC-CF-900 AEROSTART-EC-CF-1300 AEROSTART-EC-CF-2000 AEROSTART-EC-DX-900 AEROSTART-EC-DX-1300 AEROSTART-EC-DX-2000	200	428	315			2,45
C-KVK-400	AEROSTART-EC-CF-3000	200	513	400		3,2	

INSULATED AIR VALVE



C-GMK-C-40-20-0

- for regulating the flow rate of supply, recirculating or exhaust air in ducted ventilation and air conditioning systems;
- it features perimeter heating and protection against blade icing;
- it differs from standard air valves in the increased contact tightness of the blades;
- it differs in a smaller volume of flow through the valve;
- special design allows reducing heat loss through the valve flaps;
- processed air must be free of solid, fibrous, sticky or aggressive impurities;
- it is equipped with an electric drive and controlled remotely or by means of a handle;
- operating pressure up to 1 800 Pa;
- permissible temperature of the moved air is from -40° C to +50° C.

The casing is made of galvanized steel with reinforced aluminum profile blades installed inside.

The increased rigidity of the casing protects the valve from distortions in conditions of large changes in the average daily temperature. Perimeter heating is a feature of the valves. The use of perimeter heating in the design in the form of a flexible self-regulating heating cable located along the outer perimeter, constantly connected to 220 V AC mains.

The heating cable has automatic control without a rheostat and does not require an additional automatic control circuit. Externally, the cable is covered with a special insulated casing that does not extend beyond the outer dimensions of the valve flanges.

The blade adjoining is made by means of a rubber seal.

An electric drive ("open-closed", with a spring return, smooth adjustment or two-position 220 V or 24 V) can be used as an actuator.

The valve is also equipped with a terminal box for connecting automation and alarm systems.

- insulated air valve
- standard size (for rectangular connection section BXH)
- drive type (HD - manual or electric drive type (open-closed) smooth adjustment M24-SR, M220-SR, two-position M24, M220; spring return, smooth adjustment F24-SR, two-position F24, F220), 0 - to use with drive)

NOTE:

for universal model designation of electric drive, see Reference information.

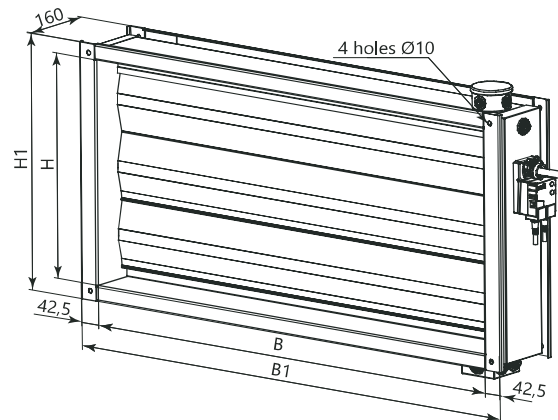

STANDARD SIZE	Type and standard size of the AHU	Dimensions, mm				Number of blades	Heating power, kW	Required torque, Nxm	Weight, kg, max
		H	H1	B	B1				
C-GMK-C-40-20	AEROSTART-EC-CF-250								
	AEROSTART-EC-CF-550								
	AEROSTART-EC-CF-900	215	285	400	485	2	0,047	4	8,5
	AEROSTART-EC-DX-550 AEROSTART-EC-DX-900								
C-GMK-C-50-25	AEROSTART-EC-CF-1300	250	335	500	585	2	0,059	4	10
	AEROSTART-EC-DX-1300								
C-GMK-C-50-30	AEROSTART-EC-CF-2000	315	385	500	585	3	0,062	4	11
	AEROSTART-EC-DX-2000								
C-GMK-C-60-35	AEROSTART-EC-CF-3000	350	435	600	685	3	0,074	4	14

CHECK VALVE



C-KOL-K-160

- check valve
- size (for round connection section)

- to seal the internal volume of sections of ventilation networks and thereby eliminate the uncontrolled flow of outdoor air into the serviced premises;
- the valve consists of a round casing made of galvanized steel and spring-loaded blades made of galvanized steel installed in it. Under the action of the moving air flow, the blades are maintained in the open position;
- maintains operability regardless of spatial orientation, provided that the installation conditions are met, as well as when ensuring an acceptable air velocity in the valve cross-section.

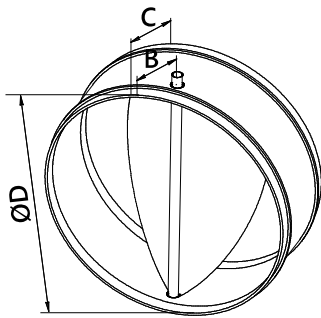

STANDARD SIZE	Type and standard size of the AHU	Dimensions, mm			Weight, kg, max
		ØD	B	C	
C-KOL-K-100	AEROSTART-EC-CF-250-LITE	100	50	80	0,23
C-KOL-K-160	AEROSTART-EC-CF-250	160	60	120	0,47
C-KOL-K-200	AEROSTART-EC-CF-550	200	80	140	0,7
C-KOL-K-250	AEROSTART-EC-DX-550	250	80	140	0,93
C-KOL-K-315	AEROSTART-EC-CF-900 AEROSTART-EC-CF-1300 AEROSTART-EC-CF-2000 AEROSTART-EC-DX-900 AEROSTART-EC-DX-1300 AEROSTART-EC-DX-2000	315	80	140	1,43
C-KOL-K-400	AEROSTART-EC-CF-3000	400	100	160	2,18

SINGLE LEAF DAMPER



C-DKK-160

- single leaf damper
- size (for round connection section)

- for regulating the flow rate of supply and exhaust air in ventilation systems;
- the valve features a round casing with a simple leaf blade installed inside, truncated on the sides. This design ensures a proportional dependence of the air flow through the valve on the blade pitch angle.

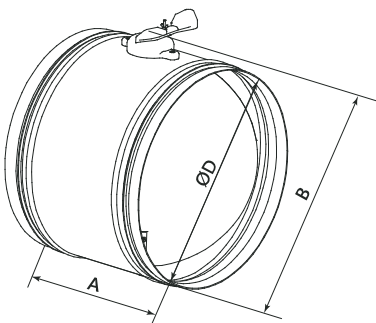

STANDARD SIZE	Type and standard size of the AHU	Dimensions, mm			Weight, kg, max
		ØD	B	A	
C-DKK-100	AEROSTART-EC-CF-250-LITE	200	160	100	0,96
C-DKK-160	AEROSTART-EC-CF-250	160	220	200	1,24
C-DKK-200	AEROSTART-EC-CF-550	200	260	200	1,45
C-DKK-250	AEROSTART-EC-DX-550	250	310	200	2,06
C-DKK-315	AEROSTART-EC-CF-900 AEROSTART-EC-CF-1300 AEROSTART-EC-CF-2000 AEROSTART-EC-DX-900 AEROSTART-EC-DX-1300 AEROSTART-EC-DX-2000	315	375	200	2,6
C-DKK-400	AEROSTART-EC-CF-3000	400	460	200	3,3

TUBULAR DUCT SILENCER

- to reduce aerodynamic noise generated during operation;
- to protect against noise in serviced premises and to reduce noise coming from fans outside (in exhaust systems);
- it is used indoor in round air ducts.

The silencer casing is made of galvanized steel. As a noise-absorbing material, mineral wool with a protective coating is used, which prevents the fibers from being blown out. The standard length of the silencer casing is 600 mm or 900 mm.

Installation of the silencers is carried out regardless of the spatial orientation, while maintaining its operability.

The design of the silencer allows it to be connected to round air ducts or units.

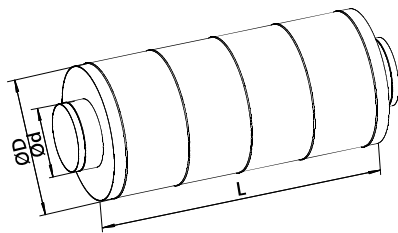

C-GKK-250-600

- tubular silencer for round ducts
- size (for round connection section)
- silencer length

STANDARD SIZE	Type and standard size of the AHU	Dimensions, mm			Weight, kg, max	Noise reduction (dB) at medium frequencies (Hz)						
		d	D	L		125	250	500	1000	2000	4000	8000
C-GKK-100-600	AEROSTART-EC-CF-250-LITE	100	200	600	4,6	7	15	25	33	29	24	17
C-GKK-100-900		100	200	900	6,3	9	22	32	36	33	31	23
C-GKK-160-600	AEROSTART-EC-CF-250	160	280	600	7,13	3	11	22	33	42	29	24
C-GKK-160-900		160	280	900	9,6	8	14	23	39	37	25	20
C-GKK-200-600	AEROSTART-EC-CF-550	200	315	600	8,35	4	8	15	31	28	20	17
C-GKK-200-900		200	315	900	11,12	8	9	20	32	35	23	18
C-GKK-250-600	AEROSTART-EC-DX-550	250	355	600	10,03	6	9	13	24	15	15	13
C-GKK-250-900		250	355	900	13,14	8	11	20	33	24	18	15
C-GKK-315-600	AEROSTART-EC-CF-900	315	500	600	16,34	2	6	11	14	9	4	2
	AEROSTART-EC-CF-1300											
	AEROSTART-EC-CF-2000											
C-GKK-315-900	AEROSTART-EC-DX-900	315	500	900	21,19	7	9	16	30	18	14	12
	AEROSTART-EC-DX-1300											
	AEROSTART-EC-DX-2000											
C-GKK-400-600	AEROSTART-EC-CF-3000	400	500	600	20,75	3	11	19	33	37	25	17
C-GKK-400-900		400	500	900	26,9	7	14	21	38	41	30	25

DUCT FILTER



C-FKK-160

- duct filter for round ducts
- size (for round connection section)

- designed for filtering air from solid and fibrous particles from supply, recirculating or exhaust air;
- protect premises and components of the ducted ventilation system against the ingress of various mechanical impurities contained in the air.
- RECOMMENDED: use the filter in front of the electric heater and fan;
- permissible temperature of the moved air is from -30° C to +50° C;
- cassettes can be supplied as part of C-FKK or separately;
- air filtration class G4.

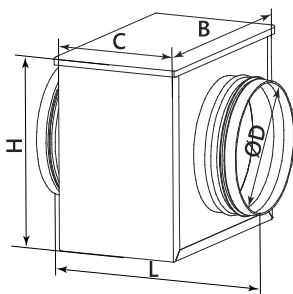

STANDARD SIZE	Type and standard size of the AHU	Dimensions, mm					Weight, kg, max
		ØD*	B	H	C	L	
C-FKK-100	AEROSTART-EC-CF-250-LITE	102	205	170	120	225	1,7
C-FKK-160	AEROSTART-EC-CF-250	162	265	235	155	265	2,87
C-FKK-200	AEROSTART-EC-CF-550	202	315	275	155	265	4,2
C-FKK-250	AEROSTART-EC-DX-550	252	365	325	155	265	5,4
C-FKK-315	AEROSTART-EC-CF-900 AEROSTART-EC-CF-1300 AEROSTART-EC-CF-2000 AEROSTART-EC-DX-900 AEROSTART-EC-DX-1300 AEROSTART-EC-DX-2000	317	425	390	155	265	7,12
C-FKK-400	AEROSTART-EC-CF-3000	402	510	475	155	275	8,64

NOTE: * upon additional request, it is possible to manufacture filters with dimensions different from those presented in the catalog.

BAG FILTER



C-FKK-100-F9-BAG

- filter for round ducts
- standard size (for round connection section)
- air filtration class
- filter type (bag filter)

- designed for filtering air from dust and fibrous particles in forced ventilation systems;
- protects premises and components of the ducted ventilation system against the ingress of various mechanical impurities contained in the air;
- permissible temperature of the moved air is from -30° C to +50° C;
- replacement cassettes can be supplied separately;
- air filtration class G4-F9.

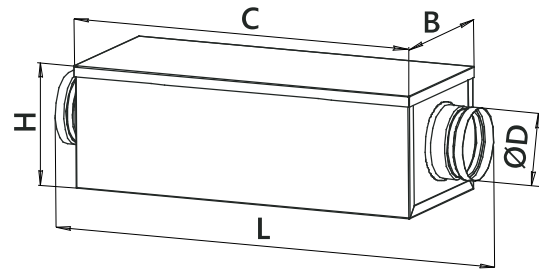

STANDARD SIZE	Type and standard size of the AHU	Dimensions, mm					Air filtration class	Weight, kg, max
		D*	B	H	C	L		
C-FKK-100-BAG	AEROSTART-EC-CF-250-LITE	98	205	170				2,5
C-FKK-160-BAG	AEROSTART-EC-CF-250	158	265	235				3,39
C-FKK-200-BAG	AEROSTART-EC-CF-550	198	315	275				4,73
C-FKK-250-BAG	AEROSTART-EC-DX-550	248	365	325				5,62
C-FKK-315-BAG	AEROSTART-EC-CF-900	313	425	390	500	620	G4, F5	6,75
	AEROSTART-EC-CF-1300							
	AEROSTART-EC-CF-2000							
	AEROSTART-EC-DX-900							
	AEROSTART-EC-DX-1300							
AEROSTART-EC-DX-2000								
C-FKK-400-BAG	AEROSTART-EC-CF-3000	398	510	475				8,32
C-FKK-100-BAG	AEROSTART-EC-CF-250-LITE	98	205	170	740	850	F7, F8, F9	3,28
	C-FKK-160-BAG	AEROSTART-EC-CF-250	158	265				
	C-FKK-200-BAG	AEROSTART-EC-CF-550	198	315		275		
	C-FKK-250-BAG	AEROSTART-EC-DX-550	248	365		325		
	AEROSTART-EC-CF-900							
	AEROSTART-EC-CF-1300							
	AEROSTART-EC-CF-2000							
	AEROSTART-EC-DX-900							
	AEROSTART-EC-DX-1300							
	AEROSTART-EC-DX-2000							
C-FKK-315-BAG	AEROSTART-EC-DX-900	313	425	390	860		8,83	
C-FKK-400-BAG	AEROSTART-EC-CF-3000	398	510	475			10,8	

NOTE: * upon additional request, it is possible to manufacture filters with dimensions different from those presented in the catalog.

ADDITIONAL EQUIPMENT

COMPACT DUCT FILTER



C-FKK-L-100

- compact filter for round ducts
- size (for round connection section)

- designed for air purification from harmful impurities, dirt and dust in general ventilation duct systems that require a minimum size of the filter casing;
- galvanized steel casing;
- nipple mounting flanges make it easy to insert the filter anywhere in the round duct system;
- a convenient snap-on access door makes replacing the filter cassette quick and easy;
- permissible temperature of the moved air is from -30° C to +50° C;
- cassettes can be supplied as part of C-FKK-L or separately;
- air filtration class G4.

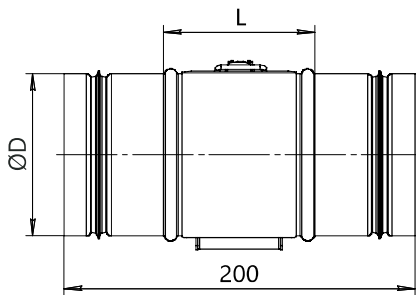

STANDARD SIZE	Type and standard size of the AHU	Dimensions, mm		Weight, kg, max
		ØD	L	
C-FKK-L-100	AEROSTART-EC-CF-250-LITE	100	85	0,45
C-FKK-L-160	AEROSTART-EC-CF-250	160		0,7
C-FKK-L-200	AEROSTART-EC-CF-550	200		0,85
C-FKK-L-250	AEROSTART-EC-DX-550	250		1,1
C-FKK-L-315	AEROSTART-EC-CF-900	315	85	1,35
	AEROSTART-EC-CF-1300			
	AEROSTART-EC-CF-2000			
	AEROSTART-EC-DX-900			
	AEROSTART-EC-DX-1300			
C-FKK-L-400	AEROSTART-EC-CF-3000	402	275	1,8

NOTE: * upon additional request, it is possible to manufacture filters with dimensions different from those presented in the catalog.

ELECTRIC AIR HEATER

- for additional air heating. The heater can also be used as a preheating device for outdoor air before the unit, or as an additional supply air heater, in case of insufficient power of the built-in air heater;
- casing and switching panel of the air heater are made of galvanized steel sheet. Terminals are installed in the switching panel to ensure easy and fast connection of the heater. The heating elements are made of stainless steel;
- maximum air temperature at the outlet of the air heater is +40° C; The minimum air flow rate is limited by the minimum air velocity in the cross-section of 1.5 m/s. The air heater is equipped with two-stage protection against overheating.

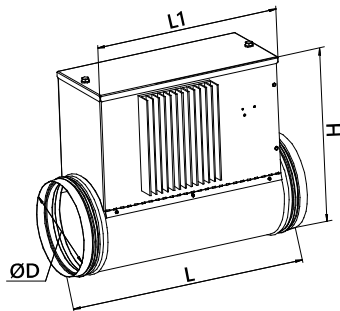

C-EVN-K-S3-250-4,5

- electric heater
- for round ducts
- type of air heater control
- size (for round connection section)
- power, kW

STANDARD SIZE	Type and standard size of the AHU	Dimensions, mm				Power, kW	Supply voltage, ~V	Current consumption, A	Min. air flow, m³/h	Weight, kg, max	Con-nection diagrams
		L	L1	D	H						
C-EVN-K-S3-100-0,6	AEROSTART-EC-CF-250-LITE	300	220	100	276	0,6	220	2,73	45	2,32	A-5
C-EVN-K-S3-100-1,2		300	220	100	276	1,2	220	5,45	45	2,32	A-5
C-EVN-K-S3-160-1,5	AEROSTART-EC-CF-250	380	300	160	315	1,5	220	7	110	3,82	A-5
C-EVN-K-S3-160-3,0		380	300	160	315	3,0	220	14	110	4,02	A-5
C-EVN-K-S3-160-4,5		380	300	160	315	4,5	380	11,84	110	4,12	A-6
C-EVN-K-S3-160-6,0		380	300	160	315	6,0	380	9,12	110	4,42	A-7
C-EVN-K-S3-200-3,0	AEROSTART-EC-CF-550	380	300	200	355	3,0	220	14	170	4,22	A-5
C-EVN-K-S3-200-4,5		380	300	200	355	4,5	380	11,84	170	4,62	A-6
C-EVN-K-S3-200-6,0		380	300	200	355	6,0	380	9,12	170	5,72	A-7
C-EVN-K-S3-250-3,0	AEROSTART-EC-DX-550	400	250	250	405	3,0	220	14	270	5,92	A-5
C-EVN-K-S3-250-4,5		400	250	250	405	4,5	380	11,84	270	6,32	A-6
C-EVN-K-S3-250-6,0		400	250	250	405	6,0	380	9,12	270	6,72	A-7
C-EVN-K-S3-250-9,0		400	250	250	405	9,0	380	13,67	270	7,22	A-7
C-EVN-K-S3-315-3,0	AEROSTART-EC-CF-900	380	300	315	470	3,0	380	9	415	7,42	A-6
C-EVN-K-S3-315-6,0	AEROSTART-EC-CF-1300	380	300	315	470	6,0	380	18	415	7,72	A-7
C-EVN-K-S3-315-9,0	AEROSTART-EC-CF-2000	380	300	315	470	9,0	380	13,67	415	8,02	A-7
C-EVN-K-S3-315-12,0	AEROSTART-EC-DX-900	380	300	315	470	12,0	380	18,23	415	8,32	A-7
C-EVN-K-S3-315-15,0	AEROSTART-EC-DX-1300	380	300	315	470	15,0	380	22,8	415	8,82	A-7
C-EVN-K-S3-400-3,0	AEROSTART-EC-CF-3000	380	300	400	562	3,0	380	9	680	9,42	A-6
C-EVN-K-S3-400-6,0		380	300	400	562	6,0	380	18	680	9,8	A-7
C-EVN-K-S3-400-9,0		380	300	400	562	9,0	380	13,67	680	10,2	A-7
C-EVN-K-S3-400-12,0		380	300	400	562	12,0	380	18,23	680	10,6	A-7
C-EVN-K-S3-400-15,0		380	300	400	562	15,0	380	22,8	680	11,2	A-7

ADDITIONAL EQUIPMENT

99

CONNECTION DIAGRAMS

A-5

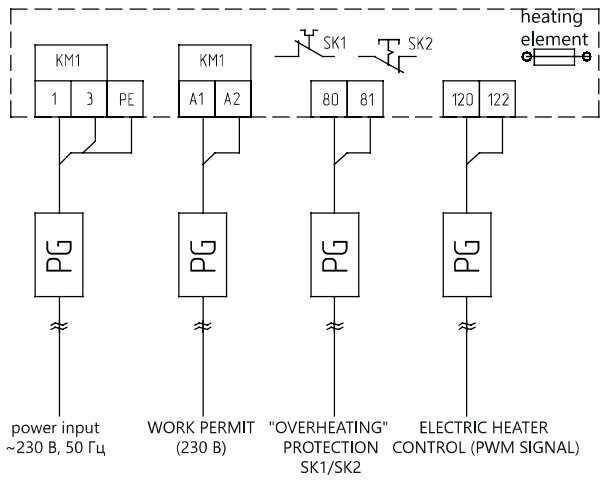

A-6

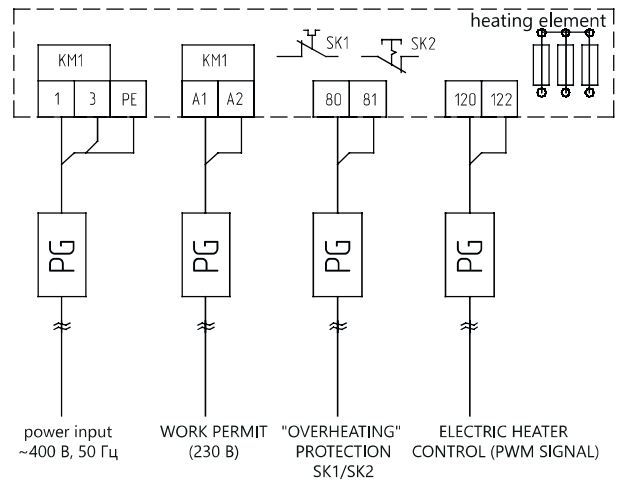

A-7

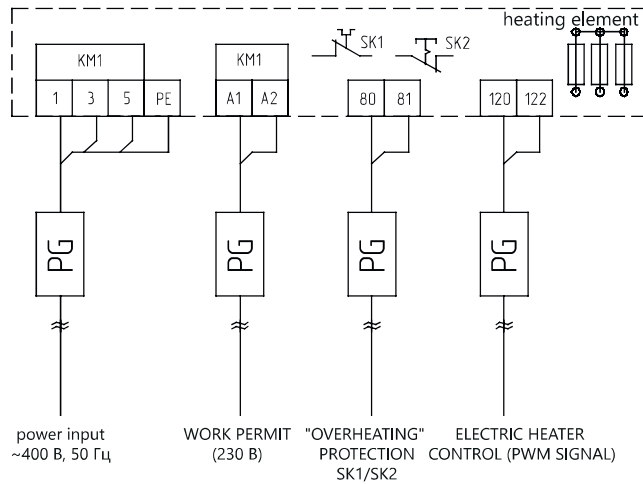

RECTANGULAR-TYPE ELECTRIC AIR HEATER

➤ for heating air in stationary ventilation systems, air conditioning of industrial, public and residential buildings, installation in rectangular ventilation ducts.

REQUIREMENTS:

- air must be free of sticky and fibrous materials, explosive gas mixtures and aggressive substances;
- content of dust and other solid impurities should not exceed 0.1 g/m³.
- maximum air temperature at the outlet of the air heater is +40° C;
- minimum air flow rate corresponds to the minimum air velocity in the casing cross-section of 1.5 m/s;
- heater supply voltage - 380 V;
- power supply voltage of the tubular heating elements is 220 V.
- Ingress protection rating IP40.

The heater is designed for additional air heating. The heater can also be used as a preheating device for outdoor air before the unit, or as an additional supply air heater, in case of insufficient power of the built-in air heater.

The wide range of C-EVN-S3 models makes it easy to choose the required heater power (from 6 to 31.5 kW) in the standard range of C-EVN sizes.

Load switching is carried out by a semiconductor device (triac), which allows for smooth heating regulation.

The heater is additionally equipped with a contactor to increase operational reliability.

C-EVN-S3 heaters are equipped with two overheat protection thermostats:

- main protection with automatic restart (response temperature +65° C). After cooling, the thermostat automatically closes the heater control circuit;
- emergency protection with manual restart (response temperature +90° C). When power is triggered, the heater can only be supplied after manual reset of the alarm.



C-EVN-S3-40-20-6

- electric duct heater
- type of air heater control: S3 - with integrated temperature controller
- standard size (for rectangular connection section BxH)
- power (kW)

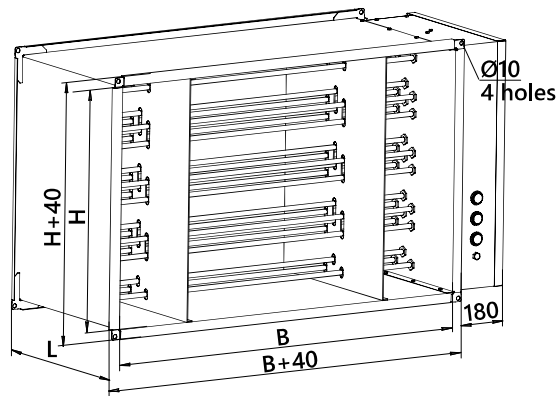

STANDARD SIZE	Type and standard size of the AHU	Dimensions, mm			Power, kW	Current consumption, A	Min. air flow, m ³ /h	Weight, kg, max
		B	H	L				
C-EVN-S3-40-20-6		400	200	220	6	9,1	450	8,4
C-EVN-S3-40-20-12	AEROSTART-EC-CF-250-LITE	400	200	220	12	18,3	450	11
C-EVN-S3-40-20-18		400	200	280	18	27,4	450	12
C-EVN-S3-50-25-12	AEROSTART-EC-CF-250	500	250	220	12	18,3	700	12,2
C-EVN-S3-50-25-18		500	250	280	18	27,4	700	13,3
C-EVN-S3-50-25-24		500	250	330	24	36,5	700	16,5
C-EVN-S3-50-30-12	AEROSTART-EC-CF-550	500	300	220	12	18,3	850	13
C-EVN-S3-50-30-18		500	300	280	18	27,4	850	15
C-EVN-S3-50-30-24		500	300	330	24	36,5	850	18
C-EVN-S3-50-30-30		500	300	390	30	45,6	850	18,9
C-EVN-S3-60-30-15	AEROSTART-EC-DX-550	600	300	370	15	22,8	1000	14,2
C-EVN-S3-60-30-22,5		600	300	370	22,5	39,4	1000	14,8
C-EVN-S3-60-30-27		600	300	500	27	41	1000	17,3
C-EVN-S3-60-30-31,5		600	300	500	31,5	47,9	1000	17,7
C-EVN-S3-60-35-16,5	AEROSTART-EC-CF-900	600	350	370	16,5	25	1200	14,8
C-EVN-S3-60-35-22,5	AEROSTART-EC-CF-1300	600	350	370	22,5	39,4	1200	16,6
	AEROSTART-EC-CF-2000							
C-EVN-S3-60-35-27	AEROSTART-EC-DX-900	600	350	500	27	41	1200	19,7
	AEROSTART-EC-DX-1300							
C-EVN-S3-60-35-31,5	AEROSTART-EC-DX-2000	600	350	500	31,5	47,9	1200	21
C-EVN-S3-70-40-27	AEROSTART-EC-CF-3000	700	400	370	27	41	1600	19,8
C-EVN-S3-70-40-31,5		700	400	370	31,5	47,9	1600	20,4
C-EVN-S3-80-50-31,5		800	500	370	31,5	47,9	2200	22

102 ADDITIONAL EQUIPMENT



WATER/AIR-HEATER



C-KVN-K-160

- water/air-heater
- size (for round connection section)

- for additional heating of the processed air, AEROSTART-EC units can be equipped with C-KVN-K water/air-heaters;
 - maximum permissible temperature of the heat carrier (water) should not exceed 150° C, the maximum permissible pressure - no more than 1.6 MPa;
 - to regulate the temperature and ensure the circulation of the heat carrier, as well as to protect heaters from freezing, UWS water mixing units and other elements of the automatic control system are used. The UWS specifications can be found below.
- Installation only on horizontal sections of air ducts.

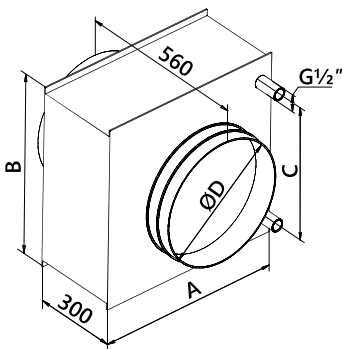

STANDARD SIZE	Type and standard size of the AHU	Dimensions, mm				Weight, kg, max
		ØD	A	B	C	
C-KVN-K-160	AEROSTART-EC-CF-250	160	300	253	225	3,6
C-KVN-K-200	AEROSTART-EC-CF-550	200	300	253	225	4,0
C-KVN-K-315	AEROSTART-EC-CF-900 AEROSTART-EC-CF-1300	315	460	479	350	5,1

WATER/AIR-HEATER



C-KVN-50-30-2

- duct water/air-heater
- standard size (for rectangular connection section BXH)
- number of rows (2, 3)

- designed to heat air using hot water as a heat carrier;
 - it is used for heating the supply, recirculating air or their mixture in compact stationary ventilation and air conditioning systems of industrial, public or residential buildings;
 - processed air must be treated and free of solid, fibrous, sticky or aggressive impurities that can cause corrosion of copper, aluminum and zinc;
- requirements for the heat carrier (water):
- maximum permissible temperature should not exceed 150° C;
 - maximum allowable pressure is not more than 1.6 MPa.

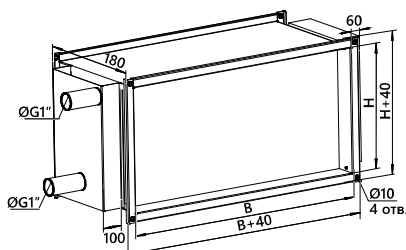

STANDARD SIZE	Type and standard size of the AHU	Dimensions, mm		Weight of two-row C-KVN, kg, max	Weight of three-row C-KVN, kg, max
		B	H		
C-KVN-50-30	AEROSTART-EC-CF-2000	500	300	6,2	7,4
C-KVN-60-35	AEROSTART-EC-CF-3000	600	350	8,7	10,4



- designed for cooling and dehumidifying supply, recirculation air or their mixture;
- in compact stationary ventilation and air conditioning systems of industrial, public or residential buildings;
- coolers are connected directly to rectangular air ducts;
- processed air must be free of solid, fibrous, sticky or aggressive impurities that contribute to the corrosion of copper, aluminum and zinc;
- water or antifreeze mixtures can be used as a refrigerant in coolers;
- maximum allowable liquid pressure in the coolers is 1.6 MPa.

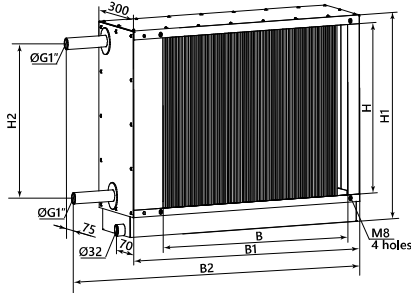

DUCT WATER/AIR-COOLER



C-VKO-40-20

- duct water/air-cooler
 - standard size
- (for rectangular connection section BXH)

NOTE:
The duct air cooler is supplied complete with a drip catcher and a pan. The siphon must be ordered and delivered separately.

STANDARD SIZE	Type and standard size of the AHU	Dimensions, mm						Weight, kg, max
		B	B1	B2	H	H1	H2	
C-VKO-40-20	AEROSTART-EC-CF-250 AEROSTART-EC-CF-550 AEROSTART-EC-CF-900	400	552	629	200	281	160	16
C-VKO-50-25	AEROSTART-EC-CF-1300	500	652	729	250	331	210	19
C-VKO-50-30	AEROSTART-EC-CF-2000	500	652	729	300	381	260	21
C-VKO-60-35	AEROSTART-EC-CF-3000	600	752	829	350	431	310	25

- designed for cooling air in ducted air conditioning and ventilation systems;
- it can be used for dehumidification;
- it is installed directly in rectangular air ducts;
- processed air must be free of solid, fibrous, sticky or aggressive impurities;
- content of substances that cause corrosion or decomposition of aluminum, copper, and zinc is unacceptable;
- as refrigerants, it is permissible to use the following Freon brands: R22, R407C, R410A.

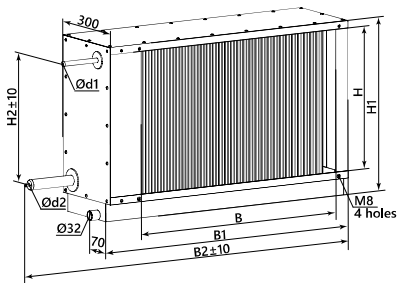

FREON AIR COOLER



C-FKO-40-20

- duct-type Freon air cooler
 - standard size
- (for rectangular connection section BXH)

NOTE:
During delivery, Freon heat exchangers are filled with inert gas, which must be removed when connected to the refrigeration circuit.

STANDARD SIZE	Type and standard size of the AHU	Dimensions, mm								Weight, kg, max
		B	B1	B2	H	H1	H2	d1	d2	
C-FKO-40-20	AEROSTART-EC-CF-250 AEROSTART-EC-CF-550 AEROSTART-EC-CF-900	400	552	719	200	283	127	12	28	16
C-FKO-50-25	AEROSTART-EC-CF-1300	500	652	819	250	333	177			18
C-FKO-50-30	AEROSTART-EC-CF-2000	500	652	819	300	383	227			19
C-FKO-60-35	AEROSTART-EC-CF-3000	600	752	919	350	433	271	16	35	23

RECTANGULAR ADAPTER



- for connecting rectangular duct fans to ventilation systems with round ducts;
- for installation of square-type fans in a rectangular air duct system;
- provides convenient and fast installation of equipment in the duct;
- it can be ordered either as a set with a fan or as a separate element of the system (optional).

AD-PSKK-T/6-1-300x700-ZS/0,5-N-200-150-60-300-F/3

- designated name
- insulation (T - insulated; 0 - without insulation)
- insulation thickness*, mm (6, 10, 15, 20)
- transition type
- size (for rectangular connection section AxB)
- material (ZS - galvanized steel; NS - stainless steel)
- steel thickness, mm (0.5; 0.7; 1.0)
- class (N - normal, P - sealed)
- size (for round connection section D, mm)
- vertical offset (E), mm
- horizontal offset (F), mm
- channel length (L, mm)
- availability of flanges (cross-section AxB) (F - flange, 0 - without flange)
- flange width (2 - 20 mm, 3 - 30 mm)

* specified only for the insulated version

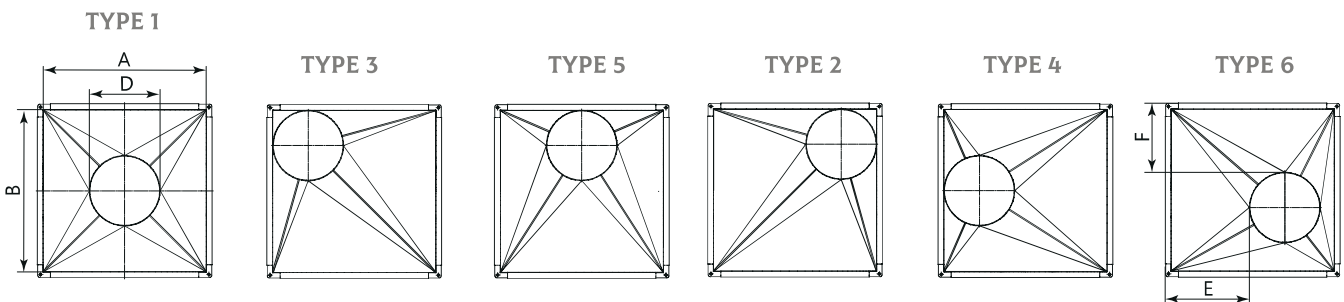

STANDARD SIZE	Type and standard size of the AHU	Weight, kg, max
AD-PSKK-0-1-400X200-ZS/0,5-N-160-0-0-300-F/2	AEROSTART-EC-CF-250	1,6
AD-PSKK-0-1-400X200-ZS/0,5-N-200-0-0-300-F/2	AEROSTART-EC-CF-550	1,7
AD-PSKK-0-1-400X200-ZS/0,5-N-250-0-0-300-F/2	AEROSTART-EC-DX-550	1,9
AD-PSKK-0-1-400X200-ZS/0,5-N-315-0-0-300-F/2	AEROSTART-EC-CF-900 AEROSTART-EC-DX-900	2
AD-PSKK-0-1-500X250-ZS/0,5-N-315-0-0-300-F/2	AEROSTART-EC-CF-1300 AEROSTART-EC-DX-1300	2,3
AD-PSKK-0-1-500X300-ZS/0,5-N-315-0-0-300-F/2	AEROSTART-EC-CF-2000 AEROSTART-EC-DX-2000	2,4
AD-PSKK-0-1-600X350-ZS/0,7-N-400-0-0-300-F/2	AEROSTART-EC-CF-3000	3,5

105 ADDITIONAL EQUIPMENT

SUPPLY AND EXHAUST GRILLE

- for supply and exhaust ventilation in round duct systems. The grille distributes the outside and exhaust air flows, eliminating the possibility of mixing them;
- made of galvanized sheet steel. The grille is equipped with a protective mesh and a connecting pipe with a special rubber seal;
- features built-in dividers that direct the flow of supply and exhaust air in different directions from the wall. The mesh can be easily removed for cleaning;
- as standard, the grille is delivered unpainted. These grilles are painted with powder paints according to the RAL catalog.



C-RPVC-160-0

- supply and exhaust grille
- size (by round connection section)
- color according to the RAL catalog
(0 - without painting)

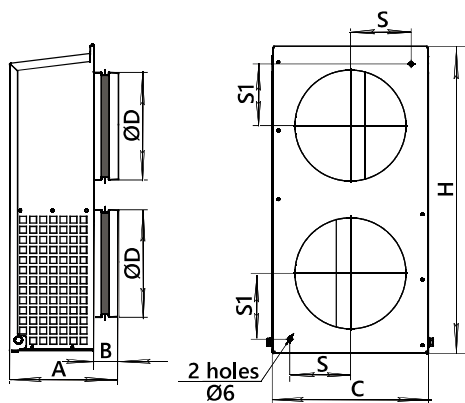

STANDARD SIZE	Type and standard size of the AHU	Dimensions, mm							Weight, kg, max
		D	B	C	H	A	S	S1	
C-RPVC-100	AEROSTART-EC-CF-250-LITE	100	37	165	385	100	65	72	2,2
C-RPVC-160	AEROSTART-EC-CF-250	160	43	240	460	163	90	98	2,9
C-RPVC-200	AEROSTART-EC-CF-550	200	43	240	486	166	90	98	2,9
C-RPVC-250	AEROSTART-EC-DX-550	250	41	355	765	180	145	170	2,9
C-RPVC-315	AEROSTART-EC-CF-900 AEROSTART-EC-CF-1300 AEROSTART-EC-CF-2000 AEROSTART-EC-DX-900 AEROSTART-EC-DX-1300 AEROSTART-EC-DX-2000	315	43	360	767	184	145	170	5,7
C-RPVC-400	AEROSTART-EC-CF-3000	400	43	500	1060	198	230	245	7,3

EXHAUST GRILLE



C-RVC-160-0

- exhaust grille
- size (for round connection section)
- color according to the RAL catalog (0 - without painting)

- for exhaust ventilation in round duct systems and is installed on the facade of the building. The grille intended for using as a decorative element;
- made of galvanized steel, equipped with a protective mesh and a connecting pipe with a special rubber seal;
- features a built-in divider that directs the air flow from the building wall;
- these grilles are painted with powder paints according to the RAL catalog. They are not painted as standard.

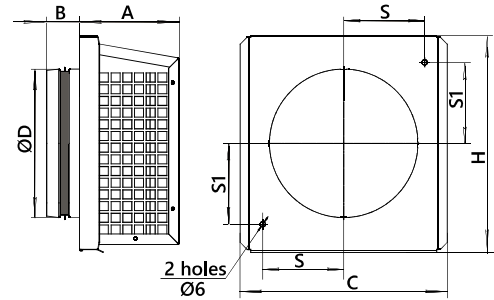

STANDARD SIZE	Type and standard size of the AHU	Dimensions, mm							Weight, kg, max
		D	B	C	H	A	S	S1	
C-RVC-100	AEROSTART-EC-CF-250-LITE	100	37	192	205	110	75	72	1,1
C-RVC-160	AEROSTART-EC-CF-250	160	37	230	243	145	90	90	1,1
C-RVC-200	AEROSTART-EC-CF-550	200	41	230	260	145	90	90	1,2
C-RVC-250	AEROSTART-EC-DX-550	250	41	282	395	200	170	170	1,4
C-RVC-315	AEROSTART-EC-CF-900 AEROSTART-EC-CF-1300 AEROSTART-EC-CF-2000 AEROSTART-EC-DX-900 AEROSTART-EC-DX-1300 AEROSTART-EC-DX-2000	315	41	395	395	200	170	170	1,3
C-RVC-400	AEROSTART-EC-CF-3000	400	43	530	530	250	245	245	1,6



AIR INTAKE GRILLE

air intake grilles intended for using as a decorative element - the unified design of the grilles makes it easy to fit them into the overall appearance of the building and structure. The grilles are used for supply ventilation in round duct systems and are installed on the facade of the building. Duct grilles protect air ducts from precipitation and ingress of foreign objects;

these grilles are painted with powder paints according to the RAL catalog. As standard, the grilles are delivered unpainted.

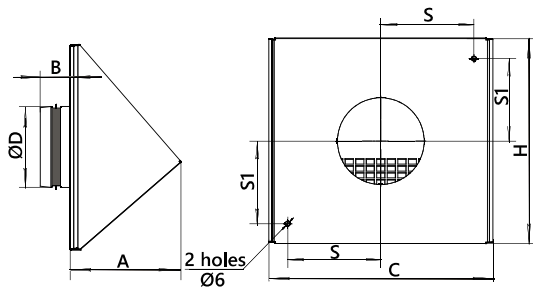

C-RVK-160-0

- air intake grille
- size (for round connection section)
- color according to the RAL catalog
(0 - without painting)

STANDARD SIZE	Type and standard size of the AHU	Dimensions, mm							Weight, kg, max
		D	B	C	H	A	S	S1	
C-RVK-100	AEROSTART-EC-CF-250-LITE	100	37	217	194	107	80	72	1,7
C-RVK-160	AEROSTART-EC-CF-250	160	37	277	254	137	115	102	1,9
C-RVK-200	AEROSTART-EC-CF-550	200	41	277	254	137	115	102	1,8
C-RVK-250	AEROSTART-EC-DX-550	250	41	416	404	210	170	177	2,2
C-RVK-315	AEROSTART-EC-CF-900 AEROSTART-EC-CF-1300 AEROSTART-EC-CF-2000 AEROSTART-EC-DX-900 AEROSTART-EC-DX-1300 AEROSTART-EC-DX-2000	315	41	416	404	210	170	177	2,1
C-RVK-400	AEROSTART-EC-CF-3000	400	43	530	530	320	245	245	3,2

NON-ADJUSTABLE GRILLE



RKN-160-0

- non-adjustable grille
- size (for round connection section)
- color according to the RAL catalog
(0 - without painting)

- for supply and exhaust ventilation, air conditioning and air heating systems. For installation in round air ducts or round wall openings;
- grille is made of galvanized steel, and a galvanized steel mesh is installed on the back side;
- characterized by high strength, easy installation and reliable operation. The grilles are fixed with glue or mortar, and it is also possible to attach them with screws (using mounting holes on the front side);
- these grilles are painted with powder paints according to the RAL catalog.

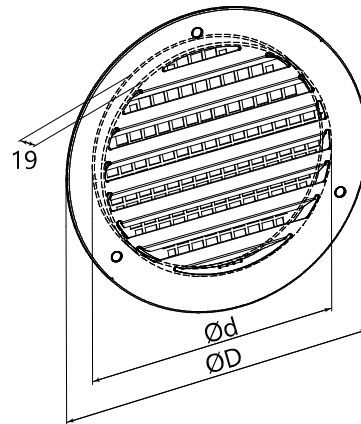

STANDARD SIZE	Type and standard size of the AHU	DIMENSIONS, MM		Weight, kg, max
		D	d	
RKN-100	AEROSTART-EC-CF-250-LITE	100	98	0,3
RKN-160	AEROSTART-EC-CF-250	210	158	0,6
RKN-200	AEROSTART-EC-CF-550	264	198	0,9
RKN-250	AEROSTART-EC-DX-550	314	248	1,1
RKN-315	AEROSTART-EC-CF-900 AEROSTART-EC-CF-1300 AEROSTART-EC-CF-2000 AEROSTART-EC-DX-900 AEROSTART-EC-DX-1300 AEROSTART-EC-DX-2000	379	313	1,6
RKN-400	AEROSTART-EC-CF-3000	464	398	2

MOUNTING CLAMP

- for connecting elements of a circular ventilation ductwork with each other and with air ducts;
- made of galvanized sheet steel. On the inside it is equipped with an insulating sealing layer, which provides tightness of the connections and reduces vibration. Provides for the presence of special bendable "eyelets", providing the possibility of hanging. The clamps are tightened with two screws. This ensures a secure fit.



C-MK-160

- mounting clamp
- size (for round connection section)

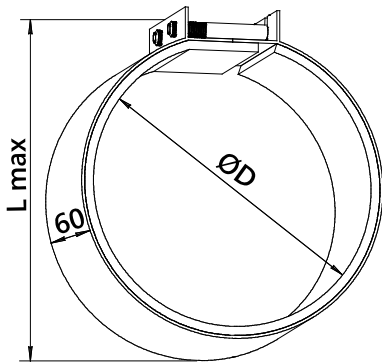

STANDARD SIZE	Type and standard size of the AHU	Dimensions, mm		Weight, kg, max
		D	L _{max}	
C-MK-100	AEROSTART-EC-CF-250-LITE	100	160	0,26
C-MK-160	AEROSTART-EC-CF-250	160	220	0,37
C-MK-200	AEROSTART-EC-CF-550	200	260	0,44
C-MK-250	AEROSTART-EC-DX-550	250	310	0,53
C-MK-315	AEROSTART-EC-CF-900 AEROSTART-EC-CF-1300 AEROSTART-EC-CF-2000 AEROSTART-EC-DX-900 AEROSTART-EC-DX-1300 AEROSTART-EC-DX-2000	315	375	0,65
C-MK-400	AEROSTART-EC-CF-3000	400	460	0,83

WATER MIXING UNIT



UWS 2-1-R

- water mixing unit
- design version:
 - with two-way valve (1),
 - with three-way valve (2)
- unit size (1, 2, 3, 4, 5)
- direction of the heat carrier flow at the UWS inlet:
 - R - right-hand, L - left-hand, E - special (economy)

- ensuring circulation and temperature control of the heat carrier in heat exchangers of ventilation systems and supply air installations;
- functions are performed by regulating the temperature of the supplied heat carrier at its constant flow rate;
- heat carrier can be water, aqueous solutions (up to 50%) of ethylene glycol and propylene glycol, saline solutions, etc.;
- complete with SAU components, UWS reliably protects the heat exchanger from freezing and damage.

A set of compact fittings that is designed to regulate the heat output and protect against freezing of water heat exchangers. Water mixing units (UWS) are used to regulate the operation parameters of both separate water heat exchangers of ducted ventilation systems and built-in heat exchangers in ventilation devices: central air conditioners and supply air chambers, compact air conditioners, air curtains.

Automatic control systems provide continuous monitoring of the main protective functions of the ventilation system, including protection against freezing.

There are two types of water mixing units:

UWS 1 - mainly used when connecting heat exchangers to a centralized heat carrier supply system.

At the same time, the operation of water mixing units does not depend on the pressure level of the heat carrier in the main pipeline.

UWS 2 - are mainly used to ensure reliable uninterrupted operation of local heating systems (using individual boilers), which require ensuring a constant flow of heat carrier not only in the internal circulation circuit, but also in the external one.

The standard size of the unit depends on the flow rate of the heat carrier (m³/h) that passes through the heat exchanger.

According to the direction of the heat carrier flow, the "right-hand" (R) and "left-hand" (L) type units are distinguished.

Special offer – UWS-E water mixing units – economy package without a thermomanometer and flexible connections at a special price. They are manufactured for standard sizes 3, 4, and 5.

UWS 1-E units are always supplied in the right-hand version (when viewed from the side of the two-way valve drive and the circulation pump motor, the heat carrier flow in the internal UWS 1-E circuit moves counterclockwise).

UWS 2-E units are always supplied in the left-hand version (when viewed from the side of the three-way valve drive and the circulation pump motor, the heat carrier flow in the internal circuit of UWS 2-E moves clockwise).

DESIGNATION	Water flow rate, m ³ /h	Head, m of water column	Kvs* m ³ /h	Belimo valve	Wilo pump	Weight, kg, max
UWS 1-1-R (L)	до 0,8	до 4	1	R 2015-1-S1	Star – RS 25/4	8
UWS 1-2-R (L)	0,81...1,3	до 6	1,6	R 2015-1P6-S1	Star – RS 25/6	8
UWS 1-3-R (L)	1,31...2,5	до 6	2,5	R 2015-2P5-S1	Star – RS 25/6	8
UWS 1-4-R (L)	2,51...3,6	до 4	4	R 2020-4-S2	Top RL 30/4	11
UWS 1-5-R (L)	3,61...6	до 6,5	6,3	R 2025-6P3-S2	Top RL 30/6,5	11

DESIGNATION	Water flow rate, m ³ /h	Head, m of water column	Kvs* m ³ /h	Belimo valve	Wilo pump	Weight, kg, max
UWS 2-1-R (L)	до 0,8	до 4	1,6	R 3015-1P6-S1	Star – RS 25/4	8
UWS 2-2-R (L)	0,81...1,3	до 6	2,5	R 3015-2P5-S1	Star – RS 25/6	8
UWS 2-3-R (L)	1,31...2,5	до 6	4	R 3015-4-S1	Star – RS 25/6	8
UWS 2-4-R (L)	2,51...3,6	до 4	6,3	R 3020-6P3-S2	Top RL 30/4	11
UWS 2-5-R (L)	3,61...6	до 6,5	10	R 3025-10-S2	Top RL 30/6,5	11

ADDITIONAL EQUIPMENT

DESIGNATION	Water flow rate, m ³ /h	Head, m of water column	Kvs* m ³ /h	Ball valve	Wilo pump	Weight, kg, max
UWS 1-3 E	1,31...2,5	до 6	2,5	R 212 P	Star-RS 25/6	7
UWS 1-4 E	2,51...3,6	до 4	4	R 212 P	Top RL 30/4	10
UWS 1-5 E	3,61...6	до 6,5	6,3	R 222 P	Top RL 30/6,5	10

DESIGNATION	Water flow rate, m ³ /h	Head, m of water column	Kvs* m ³ /h	Ball valve	Wilo pump	Weight, kg, max
UWS 2-3 E	1,31...2,5	до 6	2,5	R 312 P	Star-RS 25/6	7
UWS 2-4 E	2,51...3,6	до 4	4	R 317 P	Top RL 30/4	10
UWS 2-5 E	3,61...6	до 6,5	6,3	R 322 P	Top RL 30/6,5	10

UWS 1 – R (RIGHT-HAND VERSION)

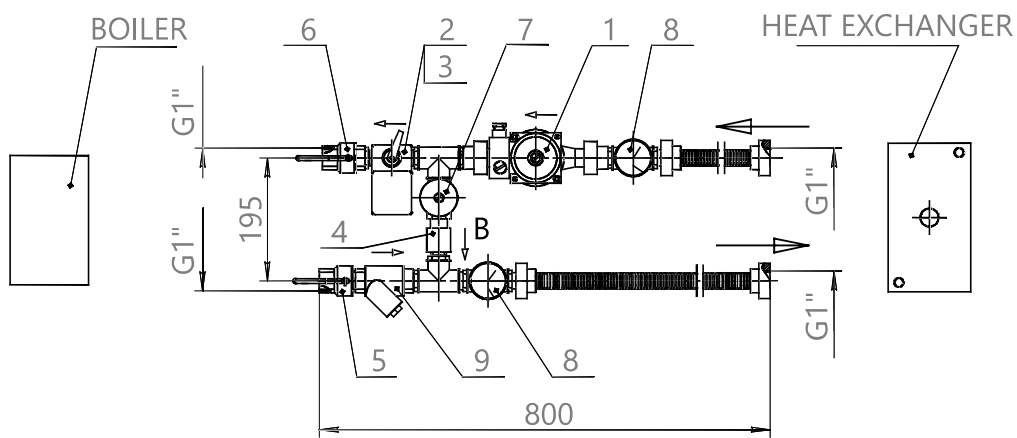

- 1 - circulation pump; 2 - two-way control ball valve; 3 - electric drive; 4 - check valve;
5, 6 - ball valves; 7 - control valve; 8 - thermomanometers; 9 - filter

UWS 1 – L (LEFT-HAND VERSION)

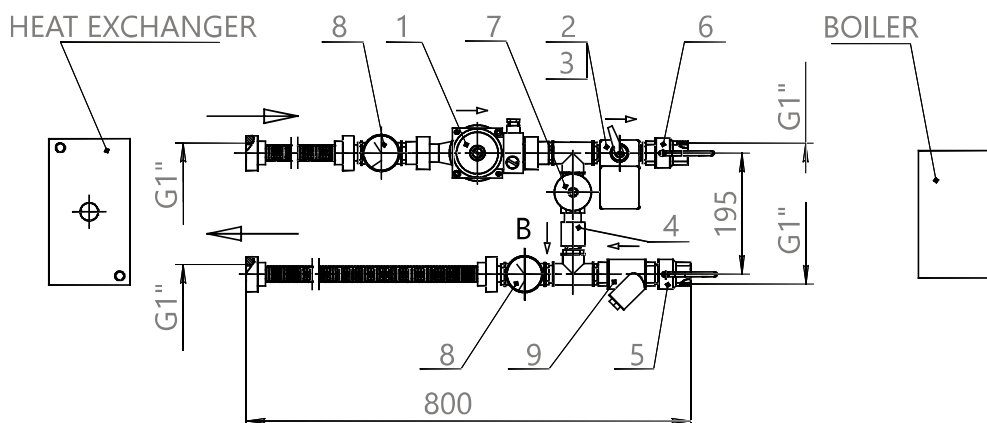

- 1 - circulation pump; 2 - two-way control ball valve; 3 - electric drive; 4 - check valve;
5, 6 - ball valves; 7 - control valve; 8 - thermomanometers; 9 - filter



UWS 1 – E (ECONOMY VERSION)

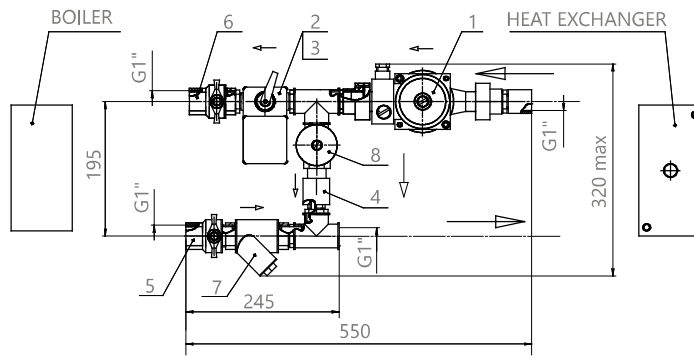

1 - circulation pump; 2 - two-way control ball valve; 3 - electric drive;
4 - check valve; 5, 6 - ball valves; 7 - filter; 8 - manual regulating valve

UWS 2 – R (RIGHT-HAND VERSION)

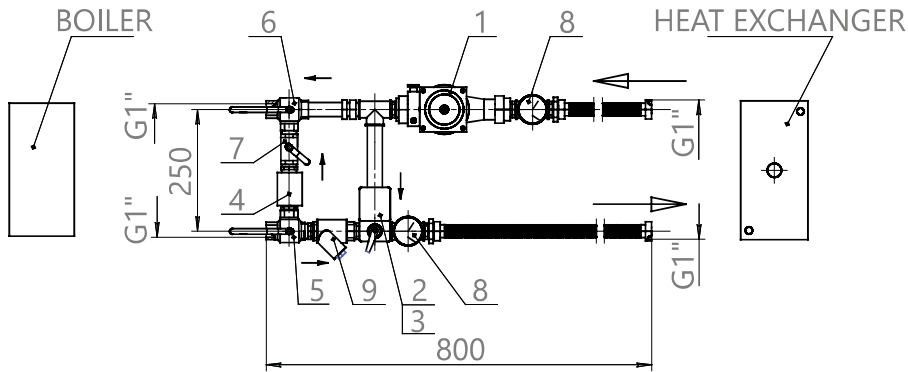

1 - circulation pump; 2 - three-way control ball valve; 3 - electric drive; 4 - check valve;
5, 6 - ball valves; 7 - control valve; 8 - thermomanometers; 9 - filter

UWS 2 – L (LEFT-HAND VERSION)

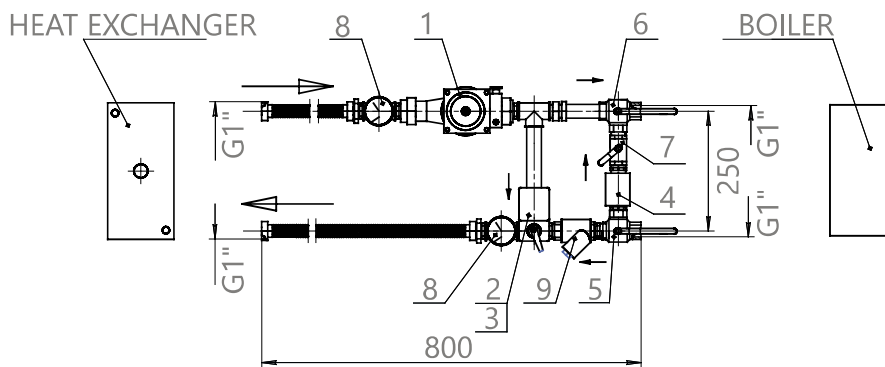

1 - circulation pump; 2 - three-way control ball valve; 3 - electric drive; 4 - check valve;
5, 6 - ball valves; 7 - control valve; 8 - thermomanometers; 9 - filter



UWS 2 – E (ECONOMY VERSION)

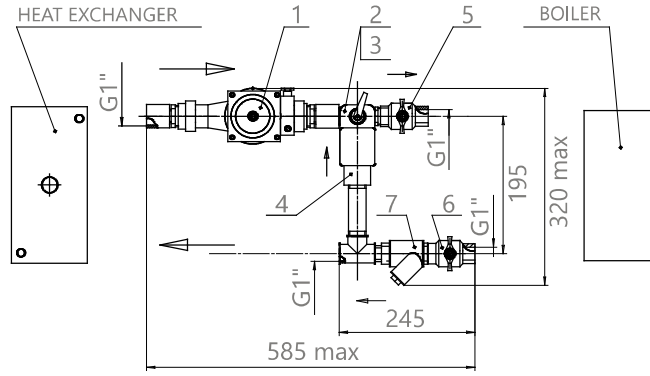

1 - circulation pump; 2 - three-way control ball valve; 3 - electric drive; 4 - check valve;
5, 6 - ball valves; 7 - filter

ADDITIONAL EQUIPMENT

The additional equipment of the AEROSMART-EC units is designed for installation outside the unit itself on the corresponding sections of air ducts when installing the unit indoors.

LIQUID AIR HEATER



SMART-WH-200-1

- liquid air heater
- block standard size
- number of rows (1, 2, 3)

- for supply air heating in air conditioning systems using AEROSMART-EC units;
- processed air must be free of solid, fibrous, sticky or aggressive impurities that contribute to the corrosion of copper, aluminum and zinc;
- block body is made using frameless technologies. The panels are covered outside with galvanized steel sheets with epoxy-polyester coating, color RAL9016. The space between the panels is filled with polyurethane foam or non-flammable mineral wool, which features high soundproofing properties;
- heat exchange surface is formed by rows of copper tubes finned with corrugated plates of aluminum foil. The heater manifolds are made of steel pipes. The materials used ensure high efficiency, reliability and durability of heaters;
- maximum permissible temperature of the heat carrier (water) should not exceed 150° C, the maximum permissible pressure - no more than 1.6 MPa. The standard size range allows selecting a heater for the appropriate air flow, which is provided by the AEROSMART-EC air handling unit;
- to regulate the temperature and ensure the circulation of the heat carrier, as well as to protect heaters from freezing, it is recommended to use UWS water mixing units.

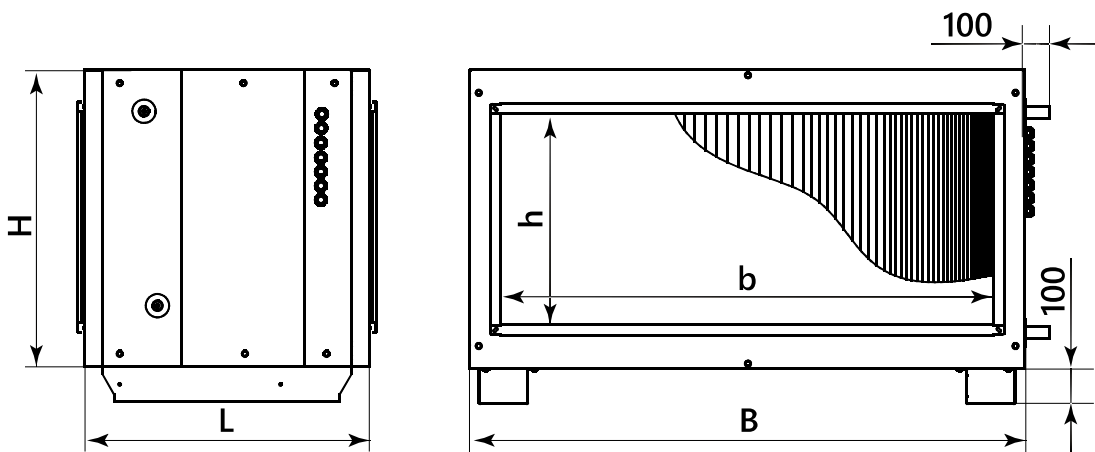

STANDARD SIZE	Type and standard size of the AHU	Dimensions, mm					Weight, kg, max
		L	B	b	H	h	
SMART-WH-200	AEROSMART-EC-200/201	700	1000	600	550	350	120
SMART-WH-300	AEROSMART-EC-300/301	700	1190	800	675	500	135
SMART-WH-400	AEROSMART-EC-400/401	700	1300	1000	700	500	155
SMART-WH-550	AEROSMART-EC-550/551	700	1550	1200	825	600	180
SMART-WH-650	AEROSMART-EC-650/651	700	1800	1400	900	600	210
SMART-WH-850	AEROSMART-EC-850/851	700	2050	1800	1025	800	250
SMART-WH-1050	AEROSMART-EC-1050/1051	700	2250	2000	1125	900	295



PRESSURE DROP CHART

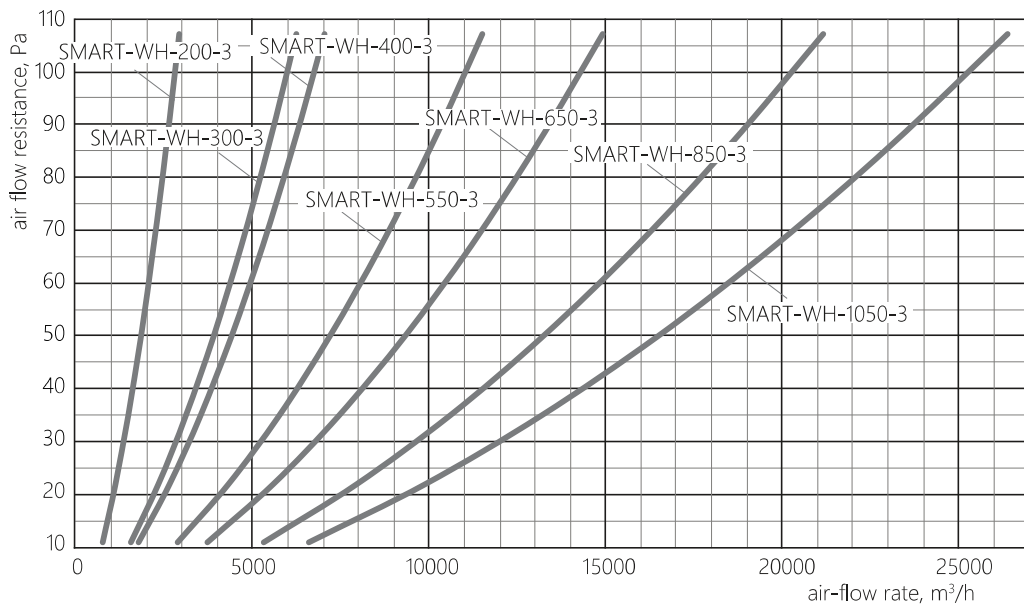
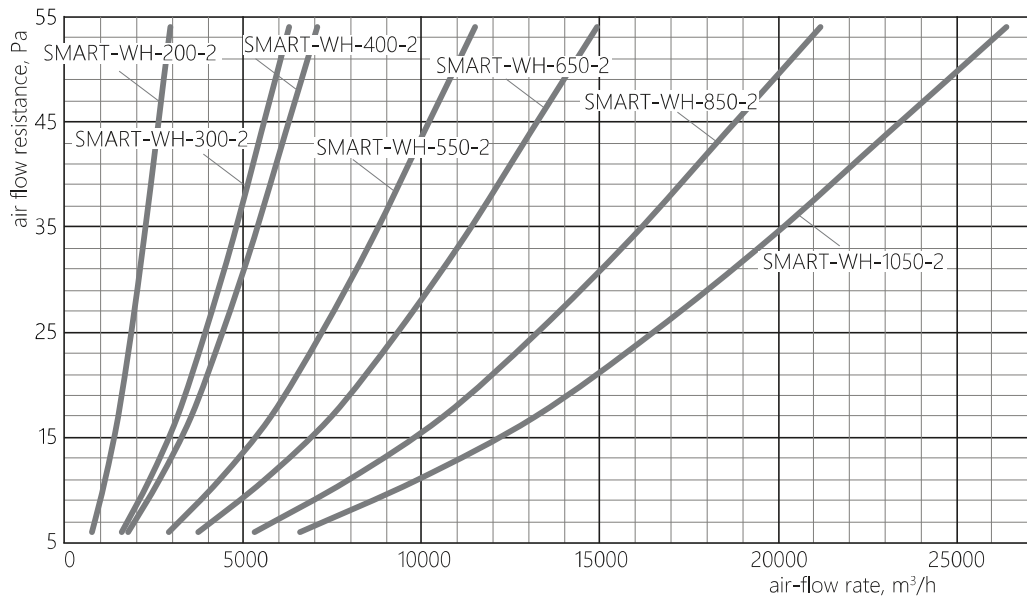
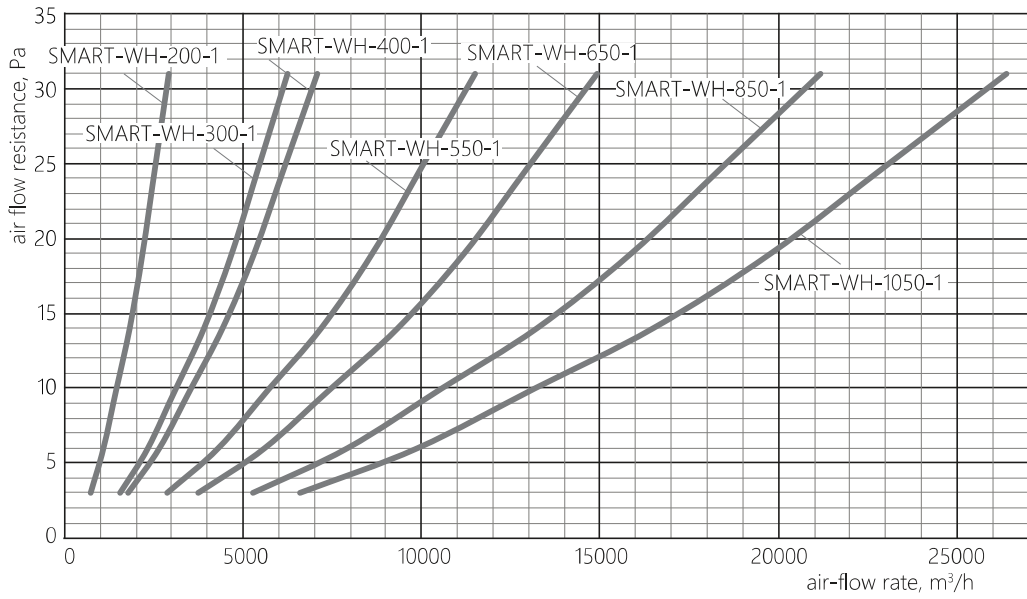

ELECTRIC AIR HEATER



SMART-EH-200-12

- ▶ electric air heater
- ▶ block standard size
- ▶ power, kW

- ▶ for additional air heating. The heater can also be used as a preheating device for outdoor air before the unit, or as an additional supply air heater, in case of insufficient power of the built-in air heater;
- ▶ body is made using frameless technologies. The panels are covered outside with galvanized steel sheets with epoxy-polyester coating, white color RAL 9016. The space between the panels is filled with polyurethane foam or NON-FLAMMABLE mineral wool, which features high soundproofing properties;
- ▶ block is equipped with a power supply and control panel. Terminals are installed in the switching panel to ensure easy and fast connection of the heater. The heating elements are made of stainless steel;
- ▶ maximum air temperature at the outlet of the air heater is +40° C; The minimum air flow rate is limited by the minimum air velocity in the cross-section of 1.5 m/s. The air heater is equipped with two-stage protection against overheating. The heater supply voltage is 380 V, the tubular heating element supply voltage is 220 V.

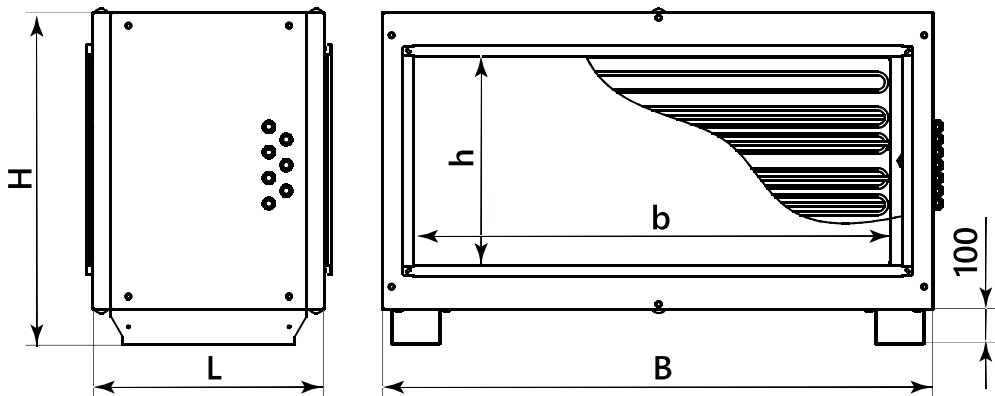

STANDARD SIZE	Type and standard size of the AHU	Dimensions, mm					Weight, kg, max
		L	B	b	H	h	
SMART-EH-200	AEROSMART-EC-200/201	1010	1000	600	550	350	185
SMART-EH-300	AEROSMART-EC-300/301	1010	1190	800	675	500	205
SMART-EH-400	AEROSMART-EC-400/401	1010	1300	1000	700	500	230
SMART-EH-550	AEROSMART-EC-550/551	1010	1550	1200	825	600	250
SMART-EH-650	AEROSMART-EC-650/651	1010	1800	1400	900	600	285
SMART-EH-850	AEROSMART-EC-850/851	1010	2050	1800	1025	800	330
SMART-EH-1050	AEROSMART-EC-1050/1051	1010	2250	2000	1125	900	375



STANDARD SIZE	Power, kW	Supply voltage	Current consumption, A
SMART-EH-200-6	6	~3/380 V/50 Hz	9
SMART-EH-200-12	12	~3/380 V/50 Hz	18
SMART-EH-200-18	18	~3/380 V/50 Hz	27
SMART-EH-200-23	23	~3/380 V/50 Hz	35
SMART-EH-200-29	29	~3/380 V/50 Hz	44
SMART-EH-200-35	35	~3/380 V/50 Hz	53
SMART-EH-300-12	12	~3/380 V/50 Hz	18
SMART-EH-300-18	18	~3/380 V/50 Hz	27
SMART-EH-300-23	23	~3/380 V/50 Hz	35
SMART-EH-300-29	29	~3/380 V/50 Hz	44
SMART-EH-300-35	35	~3/380 V/50 Hz	53
SMART-EH-300-41	41	~3/380 V/50 Hz	62
SMART-EH-300-47	47	~3/380 V/50 Hz	71
SMART-EH-400-18	18	~3/380 V/50 Hz	27
SMART-EH-400-27	27	~3/380 V/50 Hz	41
SMART-EH-400-36	36	~3/380 V/50 Hz	55
SMART-EH-400-45	45	~3/380 V/50 Hz	68
SMART-EH-400-54	54	~3/380 V/50 Hz	82
SMART-EH-400-63	63	~3/380 V/50 Hz	96
SMART-EH-400-72	72	~3/380 V/50 Hz	110
SMART-EH-550-24	24	~3/380 V/50 Hz	37
SMART-EH-550-36	36	~3/380 V/50 Hz	55
SMART-EH-550-47	47	~3/380 V/50 Hz	71
SMART-EH-550-59	59	~3/380 V/50 Hz	90
SMART-EH-550-71	71	~3/380 V/50 Hz	108
SMART-EH-550-83	83	~3/380 V/50 Hz	126
SMART-EH-550-95	95	~3/380 V/50 Hz	145
SMART-EH-650-24	24	~3/380 V/50 Hz	37
SMART-EH-650-36	36	~3/380 V/50 Hz	55
SMART-EH-650-47	47	~3/380 V/50 Hz	71
SMART-EH-650-59	59	~3/380 V/50 Hz	90
SMART-EH-650-71	71	~3/380 V/50 Hz	108
SMART-EH-650-83	83	~3/380 V/50 Hz	126
SMART-EH-650-95	95	~3/380 V/50 Hz	145
SMART-EH-650-107	107	~3/380 V/50 Hz	163
SMART-EH-650-119	119	~3/380 V/50 Hz	181
SMART-EH-850-36	36	~3/380 V/50 Hz	55
SMART-EH-850-47	47	~3/380 V/50 Hz	71
SMART-EH-850-59	59	~3/380 V/50 Hz	90
SMART-EH-850-71	71	~3/380 V/50 Hz	108
SMART-EH-850-83	83	~3/380 V/50 Hz	126
SMART-EH-850-95	95	~3/380 V/50 Hz	145
SMART-EH-850-107	107	~3/380 V/50 Hz	163
SMART-EH-850-119	119	~3/380 V/50 Hz	181
SMART-EH-850-130	130	~3/380 V/50 Hz	198
SMART-EH-850-142	142	~3/380 V/50 Hz	216
SMART-EH-1050-45	45	~3/380 V/50 Hz	68
SMART-EH-1050-59	59	~3/380 V/50 Hz	90
SMART-EH-1050-74	74	~3/380 V/50 Hz	113
SMART-EH-1050-89	89	~3/380 V/50 Hz	135
SMART-EH-1050-104	104	~3/380 V/50 Hz	158
SMART-EH-1050-119	119	~3/380 V/50 Hz	181
SMART-EH-1050-134	134	~3/380 V/50 Hz	204
SMART-EH-1050-149	149	~3/380 V/50 Hz	227
SMART-EH-1050-163	163	~3/380 V/50 Hz	248
SMART-EH-1050-178	178	~3/380 V/50 Hz	271

118 ADDITIONAL EQUIPMENT





PRESSURE DROP CHART

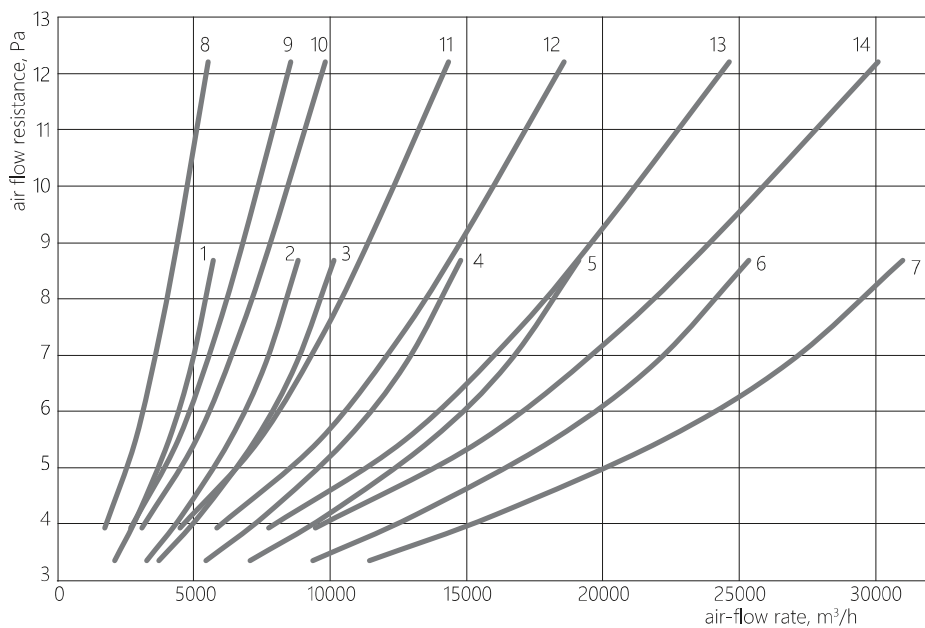

- 1 - SMART-EH-200-006
- 2 - SMART-EH-300-012
- 3 - SMART-EH-400-018
- 4 - SMART-EH-550-024
- 5 - SMART-EH-650-024, SMART-EH-650-036
- 6 - SMART-EH-850-036, SMART-EH-850-047
- 7 - SMART-EH-1050-045, SMART-EH-1050-059
- 8 - SMART-EH-200-012
- 9 - SMART-EH-300-018
- 10 - SMART-EH-400-027
- 11 - SMART-EH-550-036
- 12 - SMART-EH-650-047
- 13 - SMART-EH-850-059, SMART-EH-850-071
- 14 - SMART-EH-1050-074, SMART-EH-1050-089

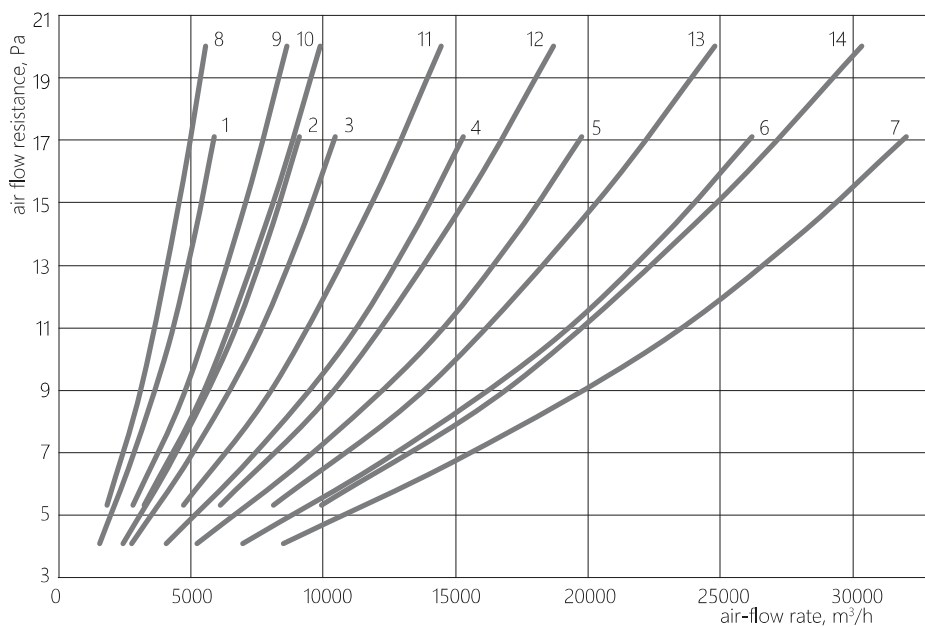

- 1 - SMART-EH-200-018
- 2 - SMART-EH-300-023, SMART-EH-300-029
- 3 - SMART-EH-400-036, SMART-EH-400-045
- 4 - SMART-EH-550-047, SMART-EH-550-059
- 5 - SMART-EH-650-059, SMART-EH-650-071
- 6 - SMART-EH-850-083
- 7 - SMART-EH-1050-104
- 8 - SMART-EH-200-023
- 9 - SMART-EH-300-035
- 10 - SMART-EH-400-054
- 11 - SMART-EH-550-071
- 12 - SMART-EH-650-083
- 13 - SMART-EH-850-095, SMART-EH-850-107
- 14 - SMART-EH-1050-119, SMART-EH-1050-134

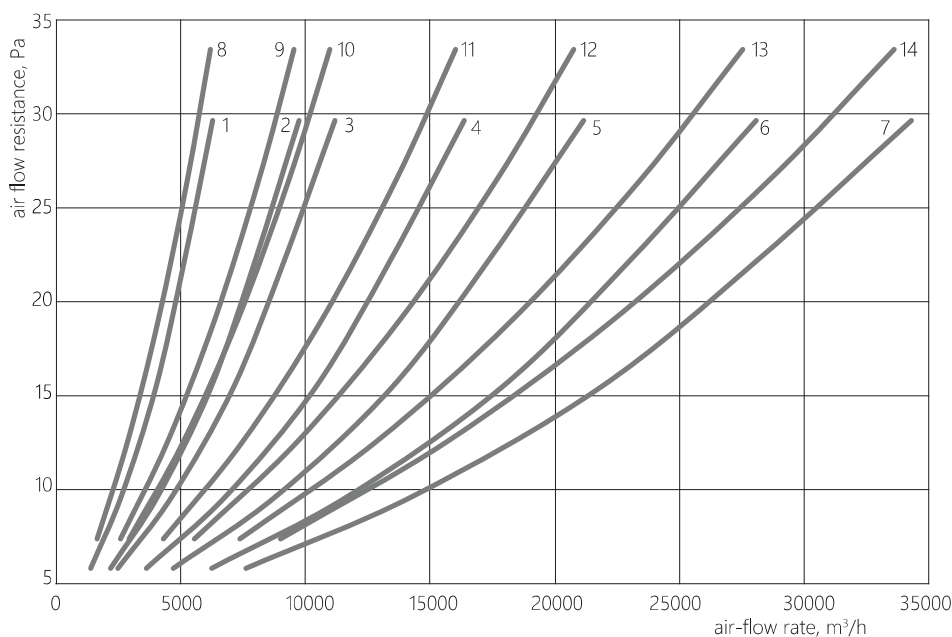

- 1 - SMART-EH-200-029
- 2 - SMART-EH-300-041
- 3 - SMART-EH-400-063
- 4 - SMART-EH-550-083
- 5 - SMART-EH-650-095, SMART-EH-650-107
- 6 - SMART-EH-850-119
- 7 - SMART-EH-1050-149
- 8 - SMART-EH-200-035
- 9 - SMART-EH-300-047
- 10 - SMART-EH-400-072
- 11 - SMART-EH-550-095
- 12 - SMART-EH-650-119
- 13 - SMART-EH-850-130, SMART-EH-850-142
- 14 - SMART-EH-1050-163, SMART-EH-1050-178



LIQUID AIR COOLER

- for supply air cooling and dehumidifying in air conditioning systems using AEROSMART-EC units;
- processed air must be free of solid, fibrous, sticky or aggressive impurities that contribute to the corrosion of copper, aluminum and zinc;
- water or antifreeze mixture can be used as a refrigerant in coolers;
- block body is made using frameless technologies. The panels are covered outside with galvanized steel sheets with epoxy-polyester coating, white color RAL 9016. The space between the panels is filled with polyurethane foam or non-flammable mineral wool, which features high soundproofing properties;
- heat exchanger, drip catcher and pan are installed inside the housing. The heat exchanger is made of copper tubes arranged in a staggered order, with aluminum fins;
- drip catcher is a set of plastic plates of a special profile shape that effectively capture condensate and collect it in a pan located in the lower part of the cooler body;
- pan is additionally heat-insulated and equipped with a discharge pipe for condensate draining. When installing the air cooler, it is necessary to ensure its horizontal position.



SMART-CW-200-4

- liquid air cooler
- block standard size
- number of rows (4, 6, 8)

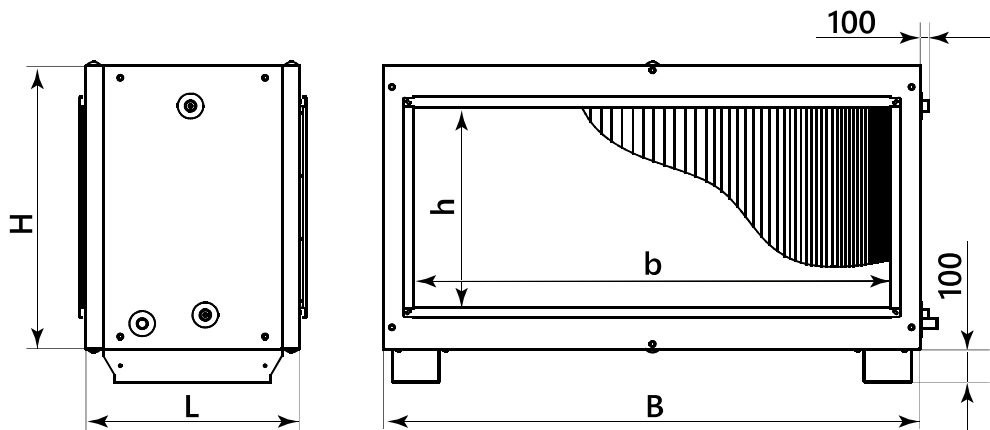

STANDARD SIZE	Type and standard size of the AHU	Dimensions, mm					Weight, kg, max
		L	B	b	H	h	
SMART-CW-200	AEROSMART-EC-200/201	700	1000	600	550	350	125
SMART-CW-300	AEROSMART-EC-300/301	700	1190	800	675	500	140
SMART-CW-400	AEROSMART-EC-400/401	700	1300	1000	700	500	160
SMART-CW-550	AEROSMART-EC-550/551	700	1550	1200	825	600	185
SMART-CW-650	AEROSMART-EC-650/651	700	1800	1400	900	600	215
SMART-CW-850	AEROSMART-EC-850/851	700	2050	1800	1025	800	260
SMART-CW-1050	AEROSMART-EC-1050/1051	700	2250	2000	1125	900	300



PRESSURE DROP CHART

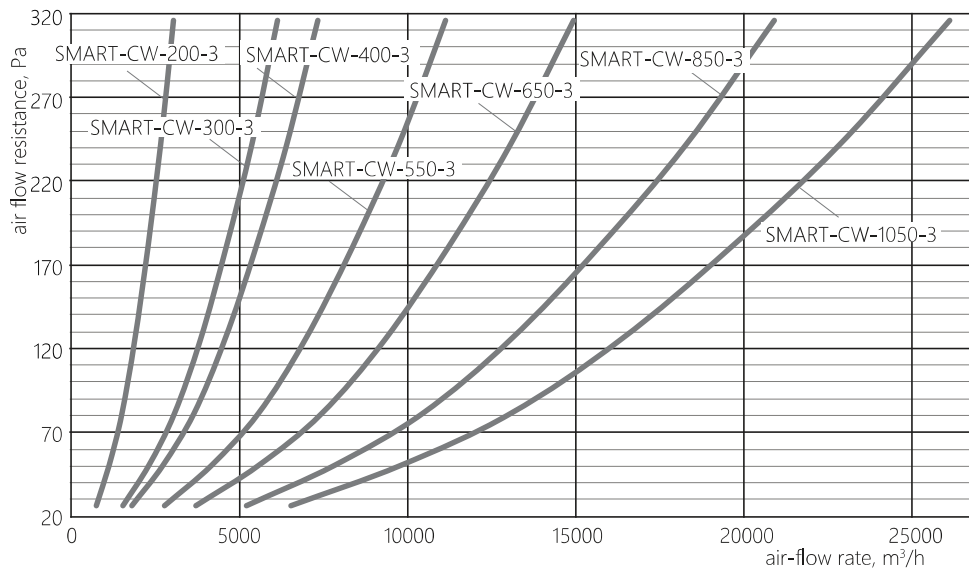
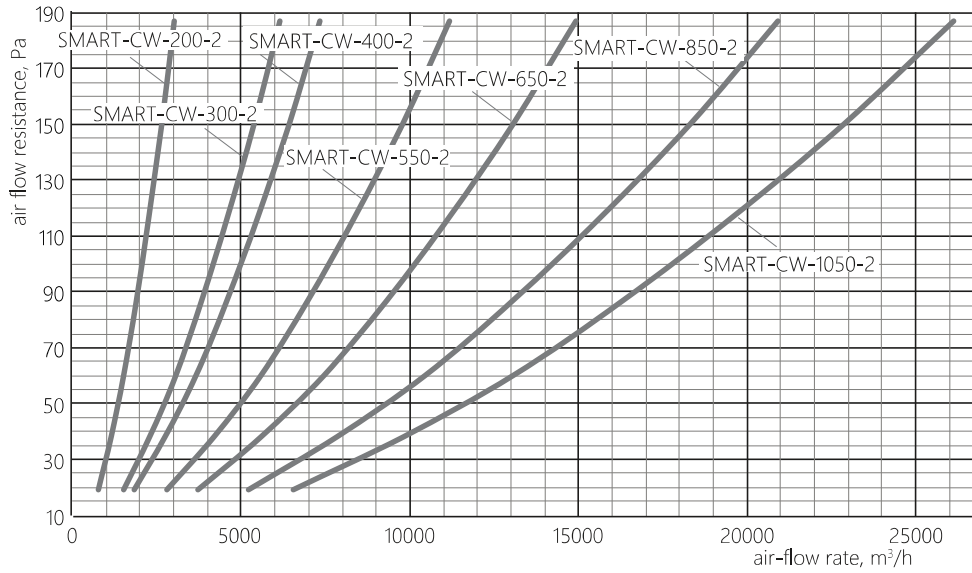
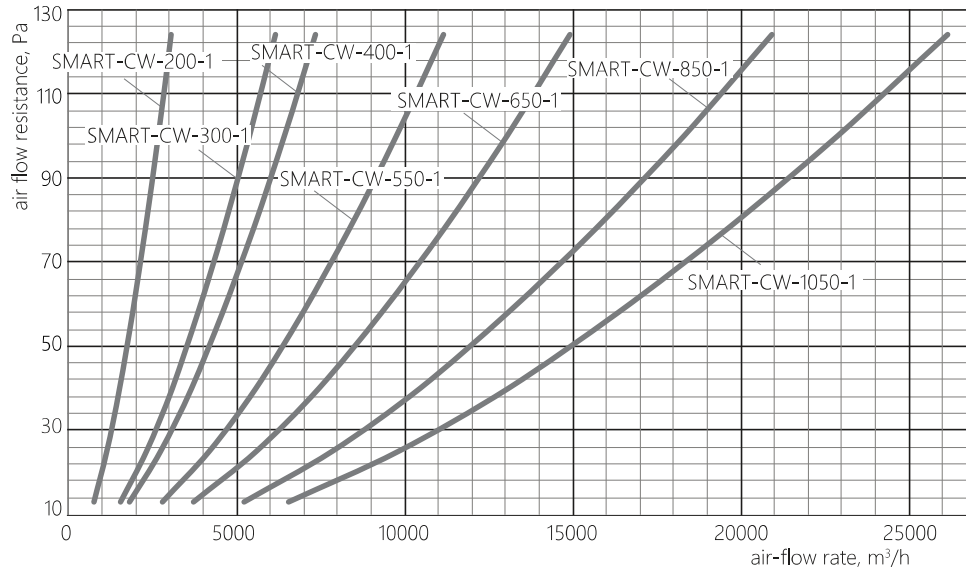

FREON AIR COOLER

- ✔ for supply air cooling and dehumidifying in air conditioning systems using AEROSMART-EC units;
- ✔ processed air must be free of solid, fibrous, sticky or aggressive impurities that contribute to the corrosion of copper, aluminum and zinc;
- ✔ 407C and R410A Freon brands can be used as a refrigerant in direct cooling heat exchangers;
- ✔ block body is made using frameless technologies. The panels are covered outside with galvanized steel sheets with epoxy-polyester coating, white color RAL 9016. The space between the panels is filled with polyurethane foam or non-flammable mineral wool, which features high soundproofing properties;
- ✔ heat exchanger, drip catcher and pan are installed inside the housing. The heat exchanger is made of copper tubes arranged in a staggered order, with aluminum fins; - drip catcher is a set of plastic plates of a special profile shape that effectively capture condensate and collect it in a pan located in the lower part of the cooler body;
- ✔ pan is additionally heat-insulated and equipped with a discharge pipe for condensate draining. When installing the air cooler, it is necessary to ensure its horizontal position. During delivery, the heat exchangers are filled with inert gas, which must be removed when connected to the refrigeration circuit.



SMART-CF-200-4

- ✔ Freon air cooler
- ✔ block standard size
- ✔ number of rows (4, 6, 8)

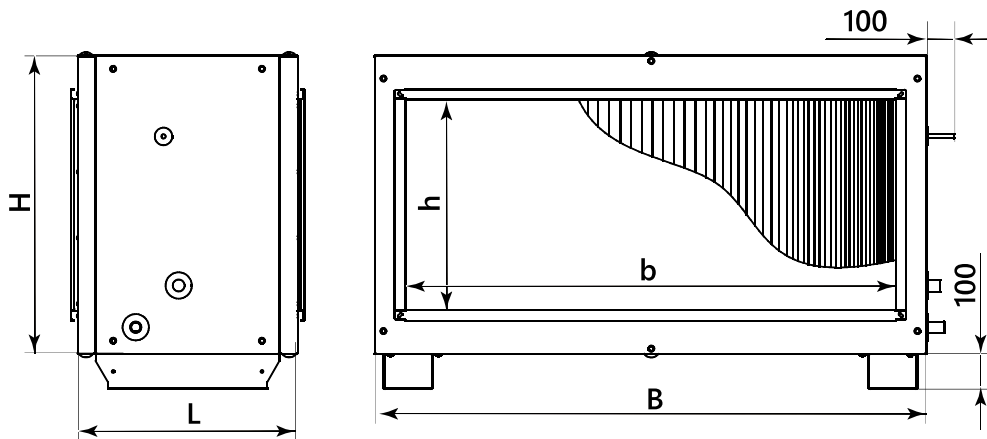

122 ADDITIONAL EQUIPMENT

STANDARD SIZE	Type and standard size of the AHU	Dimensions, mm					Weight, kg, max
		L	B	b	H	h	
SMART-CF-200	AEROSMART-EC-200/201	700	1000	600	550	350	125
SMART-CF-300	AEROSMART-EC-300/301	700	1190	800	675	500	140
SMART-CF-400	AEROSMART-EC-400/401	700	1300	1000	700	500	160
SMART-CF-550	AEROSMART-EC-550/551	700	1550	1200	825	600	185
SMART-CF-650	AEROSMART-EC-650/651	700	1800	1400	900	600	215
SMART-CF-850	AEROSMART-EC-850/851	700	2050	1800	1025	800	260
SMART-CF-1050	AEROSMART-EC-1050/1051	700	2250	2000	1125	900	300



PRESSURE DROP CHART

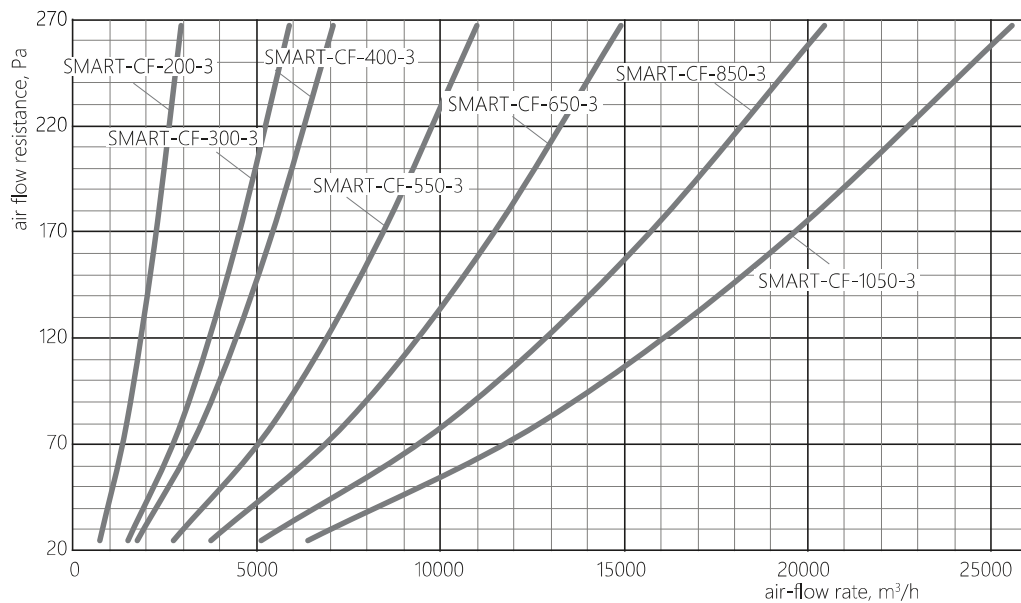
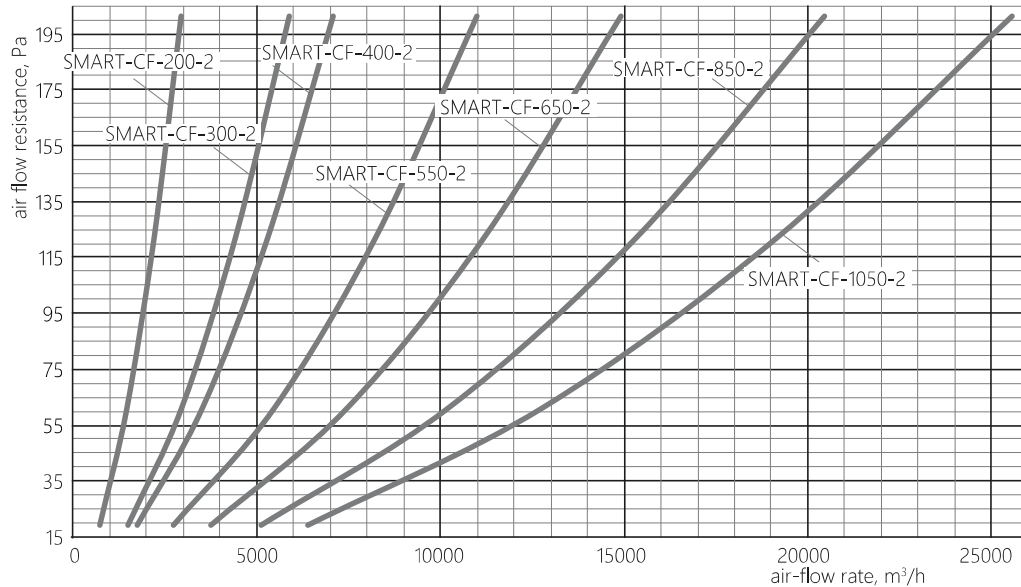
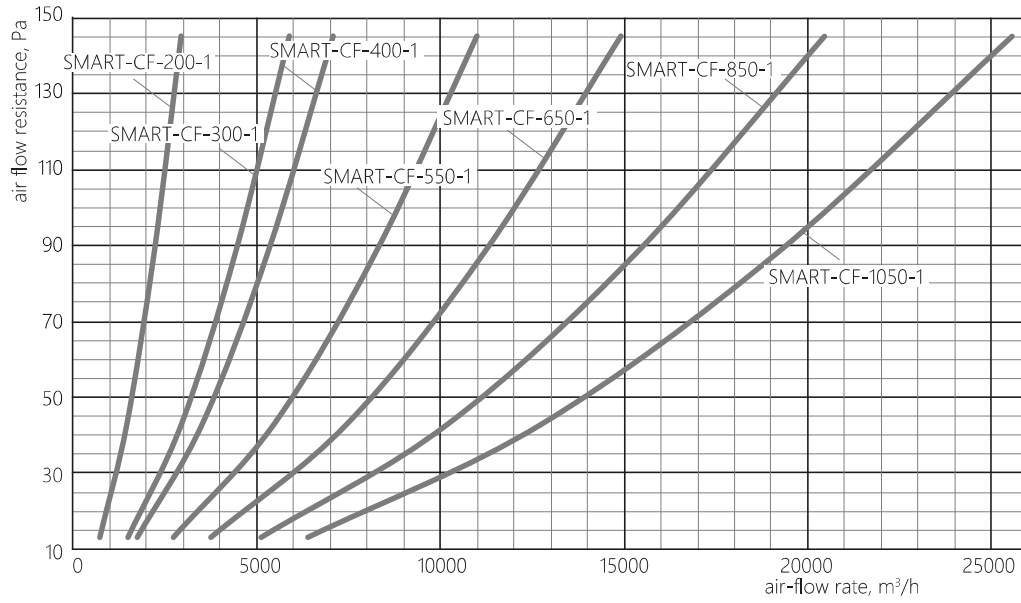

PLATE-TYPE SILENCER

- ▶ to reduce aerodynamic noise in air ducts that occurs during the operation of equipment in ventilation systems;
- ▶ principle of operation of silencers is based on the conversion of sound energy into thermal energy, due to friction, which directly allows for the suppression of aerodynamic noise;
- ▶ silencers are used both as elements of the supply and exhaust sections of the air conditioning system. Silencers are used to protect serviced areas from noise and to reduce noise coming from outside;
- ▶ body is made using frameless technologies. The panels are covered outside with galvanized steel sheets with epoxy-polyester coating, white color RAL 9016. The space between the panels is filled with polyurethane foam or non-flammable mineral wool, which features high soundproofing properties;
- ▶ plates are filled with a noise-absorbing mineral material with a protective coating that protects against erosion;
- ▶ it is recommended to provide an air duct with a length of at least 1-1.5 m in front of the silencer to equalize the air velocity along the cross-section of the duct. To further reduce the noise level, several silencers can be used, installed one after the other.



SMART-S-200-500

- ▶ plate-type silencer
- ▶ block standard size
- ▶ length (500, 1000)

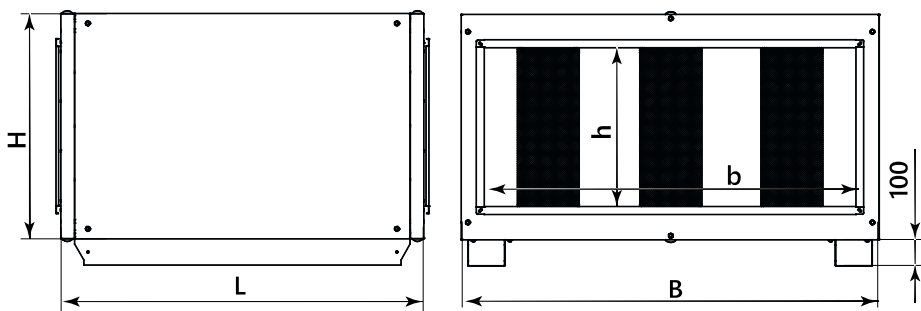

STANDARD SIZE	Type and standard size of the AHU	Dimensions, mm					Weight, kg, max
		L	B	b	H	h	
SMART-S-200-500	AEROSMART-EC-200/201	800	1000	600	550	350	85
SMART-S-300-500	AEROSMART-EC-300/301	800	1190	800	675	500	105
SMART-S-400-500	AEROSMART-EC-400/401	800	1300	1000	700	500	120
SMART-S-550-500	AEROSMART-EC-550/551	800	1550	1200	825	600	150
SMART-S-650-500	AEROSMART-EC-650/651	800	1800	1400	900	600	185
SMART-S-850-500	AEROSMART-EC-850/851	800	2050	1800	1025	800	215
SMART-S-1050-500	AEROSMART-EC-1050/1051	800	2250	2000	1125	900	240
SMART-S-200-1000	AEROSMART-EC-200/201	1300	1000	600	550	350	130
SMART-S-300-1000	AEROSMART-EC-300/301	1300	1190	800	675	500	160
SMART-S-400-1000	AEROSMART-EC-400/401	1300	1300	1000	700	500	175
SMART-S-550-1000	AEROSMART-EC-550/551	1300	1550	1200	825	600	220
SMART-S-650-1000	AEROSMART-EC-650/651	1300	1800	1400	900	600	260
SMART-S-850-1000	AEROSMART-EC-850/851	1300	2050	1800	1025	800	310
SMART-S-1050-1000	AEROSMART-EC-1050/1051	1300	2250	2000	1125	900	360



PRESSURE DROP CHART

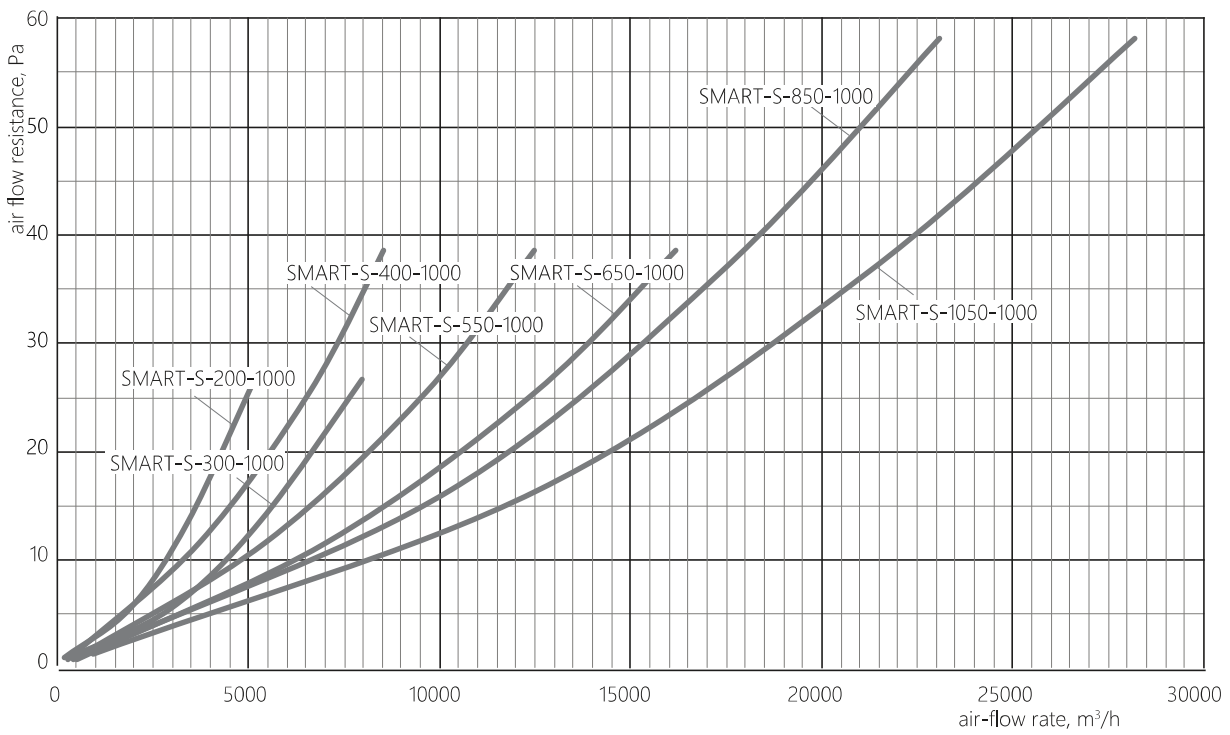
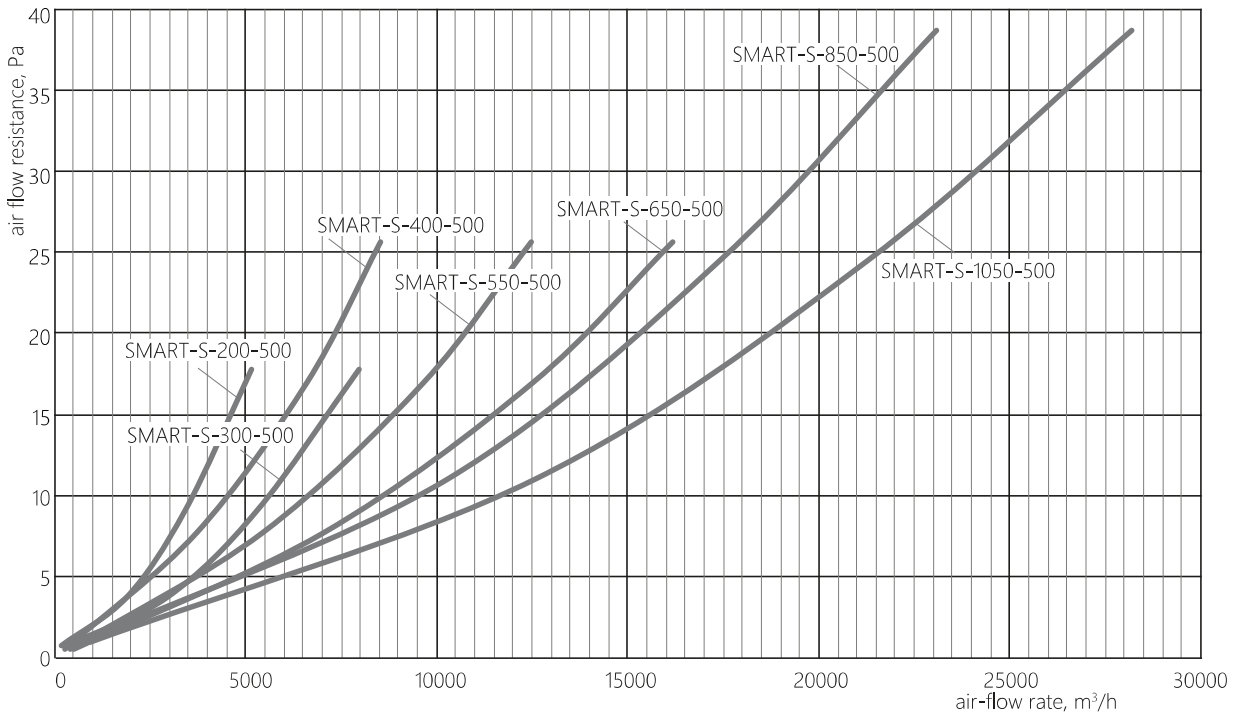

125 ADDITIONAL EQUIPMENT



AIR FILTER

- for removing solid and fibrous particles from the supply or exhaust air. Their installation protects the room and components of the ventilation system from the ingress of various mechanical impurities contained in the air;
- block body is made using frameless technologies. The panels are covered outside with galvanized steel sheets with epoxy-polyester coating, white color RAL 9016. The space between the panels is filled with polyurethane foam or non-flammable mineral wool, which features high soundproofing properties;
- filter cassette is installed in the casing. As standard, the filters are equipped with cassettes of filtration class G4, F7 and F9. Upon additional request, filters can be equipped with cassettes of other filtration classes;
- for ease of maintenance and replacement of the filter cassette, the casing is equipped with a removable panel. The filter insert is a flat panel cassette (G4) or bag-type cassette (F7, F9) made of synthetic material. The cassette casing is made of galvanized steel or plastic profile;
- permissible temperature of the moved air varies from -30° C to +50° C.



SMART-F-200-G4

- air filter
- block standard size
- air filtration class

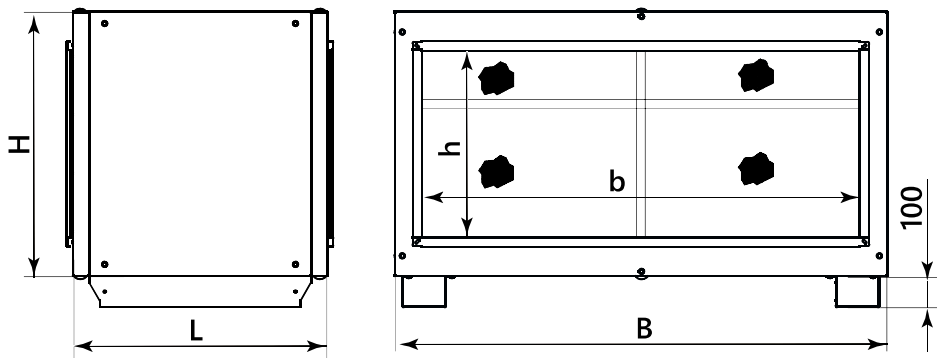

STANDARD SIZE	Type and standard size of the AHU	Dimensions, mm					Weight, kg, max
		L	B	b	H	h	
SMART-F-200-G4	AEROSMART-EC-200/201	500	1000	600	550	350	75
SMART-F-300-G4	AEROSMART-EC-300/301	500	1190	800	675	500	90
SMART-F-400-G4	AEROSMART-EC-400/401	500	1300	1000	700	500	105
SMART-F-550-G4	AEROSMART-EC-550/551	500	1550	1200	825	600	122
SMART-F-650-G4	AEROSMART-EC-650/651	500	1800	1400	900	600	140
SMART-F-850-G4	AEROSMART-EC-850/851	500	2050	1800	1025	800	165
SMART-F-1050-G4	AEROSMART-EC-1050/1051	500	2250	2000	1125	900	190
SMART-F-200-F7/F9	AEROSMART-EC-200/201	1030	1000	600	550	350	105
SMART-F-300-F7/F9	AEROSMART-EC-300/301	1030	1190	800	675	500	120
SMART-F-400-F7/F9	AEROSMART-EC-400/401	1030	1300	1000	700	500	135
SMART-F-550-F7/F9	AEROSMART-EC-550/551	1030	1550	1200	825	600	160
SMART-F-650-F7/F9	AEROSMART-EC-650/651	1030	1800	1400	900	600	190
SMART-F-850-F7/F9	AEROSMART-EC-850/851	1030	2050	1800	1025	800	210
SMART-F-1050-F7/F9	AEROSMART-EC-1050/1051	1030	2250	2000	1125	900	250



PRESSURE DROP CHART

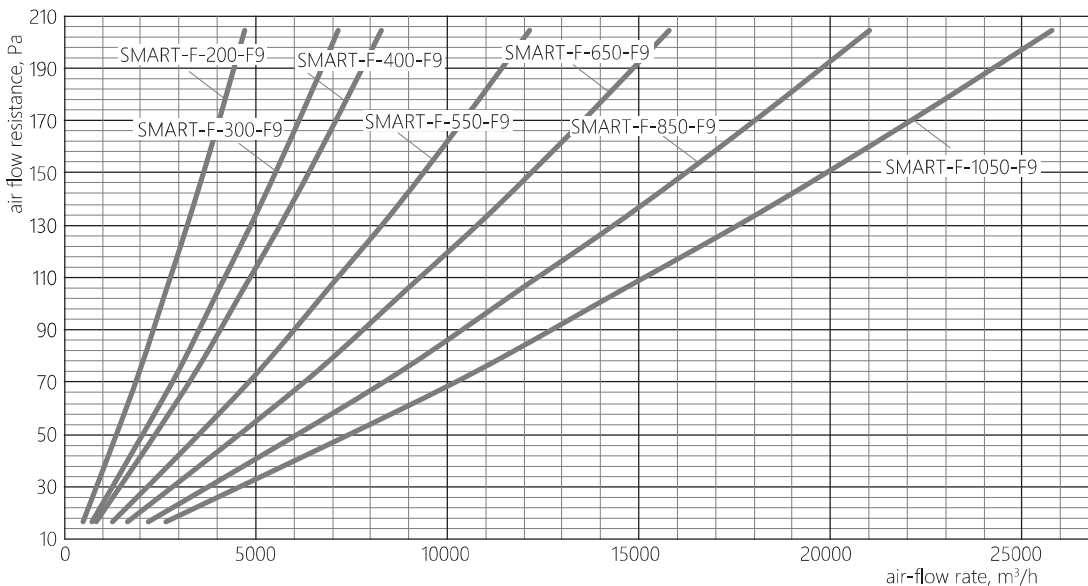
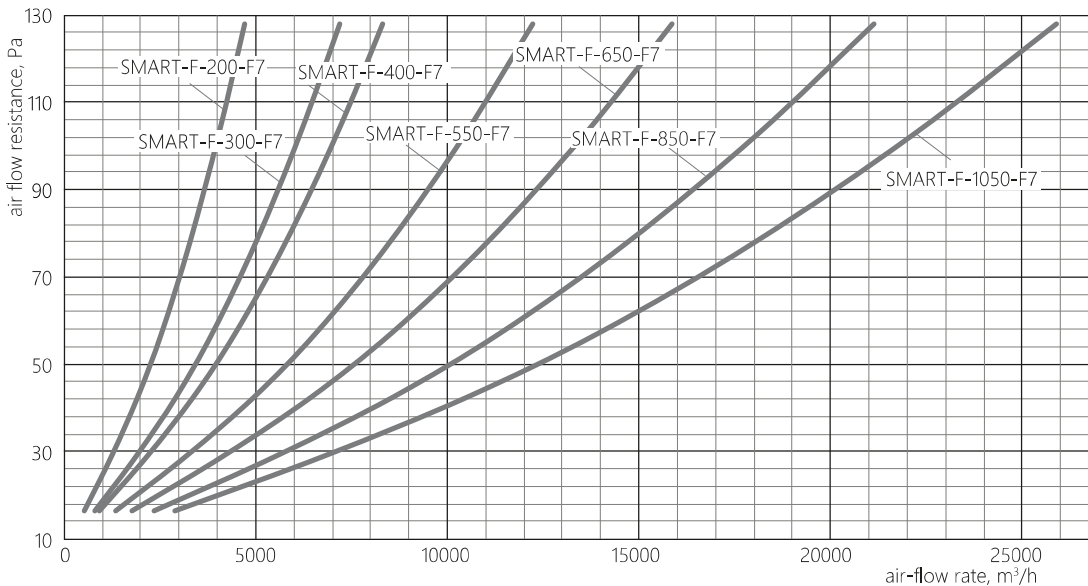
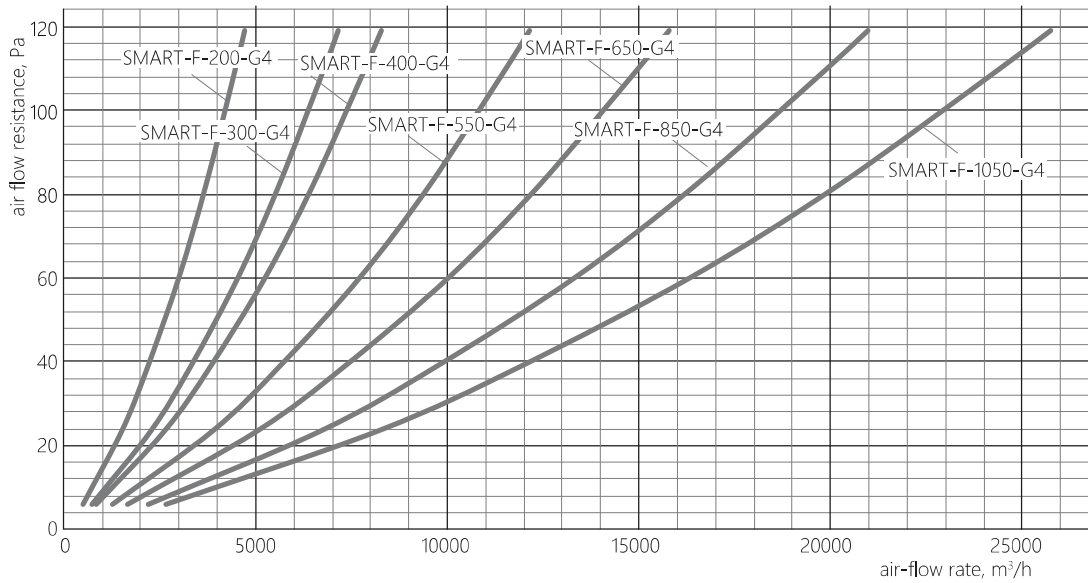

AIR VALVE

- for regulating the flow rate of supply, recirculating or exhaust air in ducted ventilation and air conditioning systems;
- no perimeter heating or protection against blade icing;
- it differs from standard air valves in the increased contact tightness of the blades;
- it differs in a smaller volume of flow through the valve;
- special design allows reducing heat loss through the valve flaps;
- processed air must be free of solid, fibrous, sticky or aggressive impurities;
- it is equipped with an electric drive and is controlled remotely or by means of a handle;
- operating pressure up to 1800 Pa;
- permissible temperature of the moved air is from -40° C to +50° C.



SMART-HD-200

- air valve
- block standard size

The valves are intended to be of exclusively rectangular design. The four-wall casing is made of galvanized steel with reinforced aluminum profile blades installed inside. The valve has a special spring-elastic seal on the ends of the flaps.

The increased rigidity of the casing protects the valve from distortions in conditions of large changes in the average daily air temperature. An elastic seal is provided in the flaps adjoining area.

The SMART-HD valve does not include any heating elements. Parallel opening of the blades is ensured by the drive kinematic diagram of this valve, which has a system of levers and rods. The blade adjoining is made by means of a rubber seal. As an actuator, a handle or an electric drive can be used ("open-closed", with a spring return, two-position 24 V).

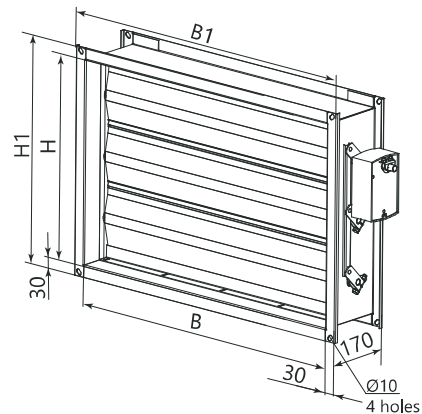

STANDARD SIZE	Type and standard size of the AHU	Dimensions, mm				Number of blades	Weight, kg, max
		H	H1	B	B1		
SMART-HD-200	AEROSMART-EC-200/201	350	410	600	660	2	9,5
SMART-HD-300	AEROSMART-EC-300/301	500	560	800	860	3	14,2
SMART-HD-400	AEROSMART-EC-400/401	500	560	1000	1060	3	16,6
SMART-HD-550	AEROSMART-EC-550/551	600	660	1200	1260	4	21,9
SMART-HD-650	AEROSMART-EC-650/651	600	660	1400	1460	4	24,8
SMART-HD-850	AEROSMART-EC-850/851	800	860	1800	1860	5	34,7
SMART-HD-1050	AEROSMART-EC-1050/1051	900	960	2000	2060	6	42,3

INSULATED AIR VALVE



SMART-ND-200

- ✔ insulated air valve
- ✔ block standard size

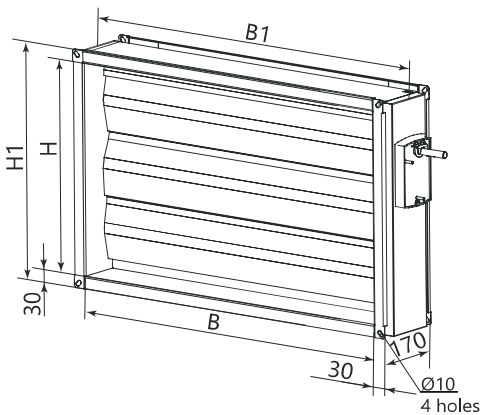

- ✔ for regulating the flow rate of supply, recirculating or exhaust air in ducted ventilation and air conditioning systems;
- ✔ it features perimeter heating and protection against blade icing;
- ✔ it differs from standard air valves in the increased contact tightness of the blades;
- ✔ it differs in a smaller volume of flow through the valve;
- ✔ special design allows reducing heat loss through the valve flaps;
- ✔ processed air must be free of solid, fibrous, sticky or aggressive impurities;
- ✔ it is equipped with an electric drive and is controlled remotely or by means of a handle;
- ✔ operating pressure up to 1800 Pa;
- ✔ permissible temperature of the moved air is from -40° C to +50° C.

The casing is made of galvanized steel with reinforced aluminum profile blades installed inside.

The increased rigidity of the casing protects the valve from distortions in conditions of large changes in the average daily temperature. Perimeter heating is a feature of the valves. The use of perimeter heating in the design in the form of a flexible self-regulating heating cable located along the outer perimeter, constantly connected to 220 V AC mains.

The heating cable has automatic control without a rheostat and does not require an additional automatic control circuit. Externally, the cable is covered with a special insulated casing that does not extend beyond the outer dimensions of the valve flanges.

The blade adjoining is made by means of a rubber seal. An electric drive ("open-closed", with a spring return, two-position 24 V) can be used as an actuator.

The valve is also equipped with a terminal box for connecting automation and alarm systems.

STANDARD SIZE	Type and standard size of the AHU	Dimensions, mm				Number of blades	Heating power, kW	Weight, kg, max
		H	H1	B	B1			
SMART-ND-200	AEROSMART-EC-200/201	350	410	600	660	2	152	12,8
SMART-ND-300	AEROSMART-EC-300/301	500	560	800	860	3	208	18
SMART-ND-400	AEROSMART-EC-400/401	500	560	1000	1060	3	240	21,3
SMART-ND-550	AEROSMART-EC-550/551	600	660	1200	1260	4	288	27,1
SMART-ND-650	AEROSMART-EC-650/651	600	660	1400	1460	4	320	30,5
SMART-ND-850	AEROSMART-EC-850/851	800	860	1800	1860	5	416	42,1
SMART-ND-1050	AEROSMART-EC-1050/1051	900	960	2000	2060	6	464	50,2



PRESSURE DROP CHART

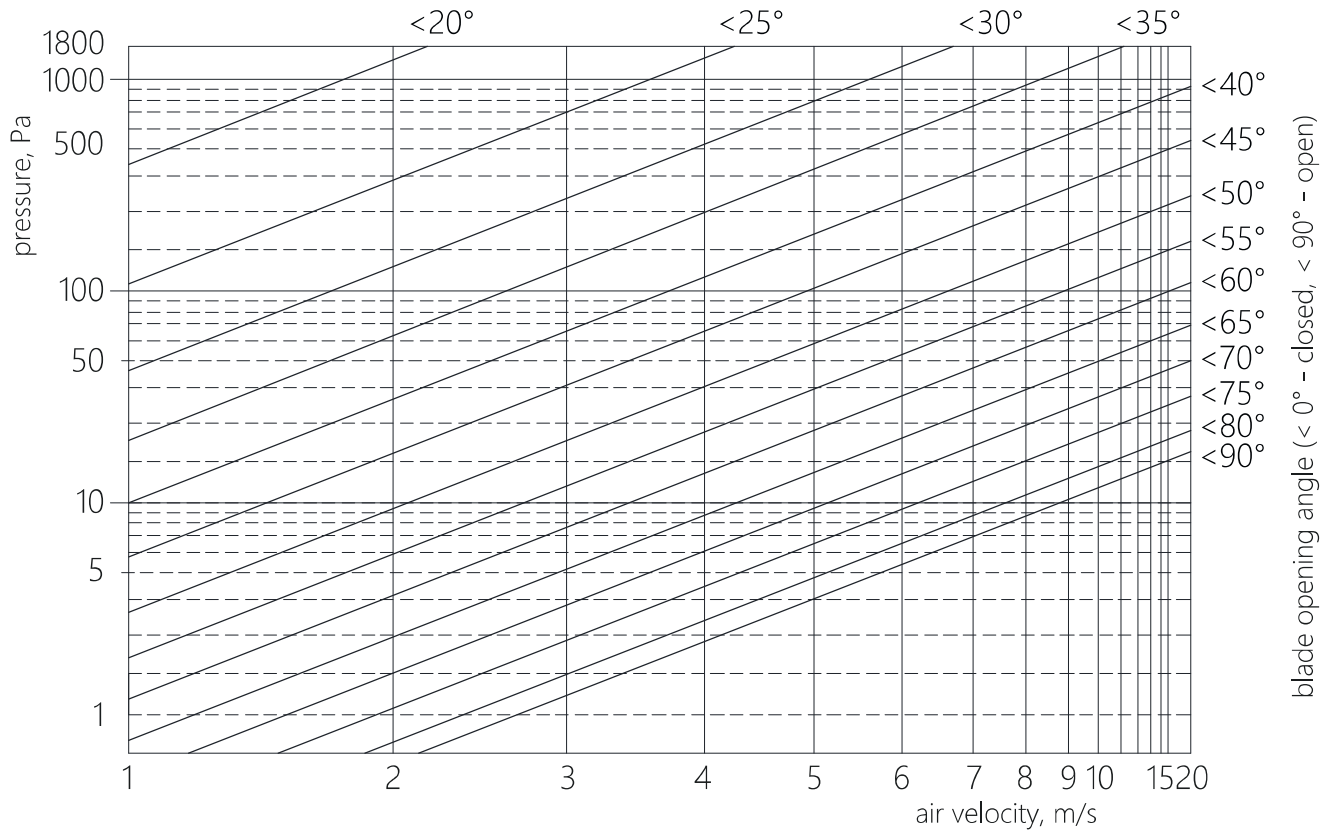

130 ADDITIONAL EQUIPMENT



ADDITIONAL SENSORS

Sensors of additional equipment of AEROSTART-EC-CF units are designed for installation outside the air handling unit on the corresponding sections of the air duct.

AIR QUALITY SENSORS



indoor duct-type

AST-AQDM

- ✔ for AEROSTART-EC-CF air handling unit
- ✔ air quality sensor (AQDM - duct-type, AQRM - indoor)

- ✔ designed to determine the quality of air inside ducts - AST-AQDM;
- ✔ designed to determine indoor air quality - AST-AQRM;
- ✔ sensors detect gases and vapors of organic origin: body odors, tobacco smoke, odors emitted by various objects and materials (furniture, paint, glue, etc.).

APPLICATION: the air quality sensor is used to ensure the operation of the "Air Quality Maintenance Function".

Specifications	Value	
	AST-AQDM	AST-AQRM
Ambient temperature range, °C	0...+50	0...+50
Outside relative humidity (without condensation), %	85	85
Enclosure ingress protection rating, IP	20	20
Air velocity inside the duct, max., m/s	10	—

CO₂ SENSORS



indoor duct-type

AST-CO2DM

- ✔ for AEROSTART-EC-CF air handling unit
- ✔ CO₂ sensor (CO₂DM - duct-type, CO₂RM - indoor)

- ✔ designed to measure carbon dioxide (CO₂) concentration inside air ducts - AST-CO₂DM
- ✔ designed to measure indoor carbon dioxide (CO₂) concentration - AST-CO₂RM.

APPLICATION: the humidity sensor is used to ensure the operation of the "Air Quality Maintenance Function".

Specifications	Value	
	AST-CO ₂ DM	AST-CO ₂ RM
Ambient temperature range, °C	0...+50	0...+50
Outside relative humidity (without condensation), %	85	85
Enclosure ingress protection rating, IP	20	20
Air velocity inside the duct, max., m/s	10	—
Measurement range, ppm	0...2 000	0...2 000
Measurement accuracy (for the measurement range at 25° C)	±40 ppm+3%	±40 ppm+3%

HUMIDITY SENSORS

- designed to measure relative humidity inside air ducts - AST-RHDM;
- designed to measure the relative humidity of indoor air - AST-RHRM.

APPLICATION: the humidity sensor is used to ensure the operation of the "Air Quality Maintenance Function".



AST-RHDM

- for AEROSTART-EC-CF air handling unit
 - humidity sensor
- (RHDM - duct-type, RHRM - indoor)

Specifications	Value	
	AST-RHDM	AST-RHRM
Ambient temperature range, °C	-20...+70	-20...+70
Outside relative humidity (without condensation), %	85	85
Enclosure ingress protection rating, IP	65	30
Air velocity inside the duct, max., m/s	12	—
Measurement range, ppm	0...100	0...100
Measurement accuracy	±2 % in the measurement range 10...90 %	±3 % in the measurement range 20...85 %

HYGROSTAT

- designed to control the relative humidity inside air ducts - AST-RHDM-SW;
- designed to control the relative humidity of indoor air - AST-RHDM-SW.

APPLICATION: the hygrostat is used to ensure the operation of the "High Intensity Ventilation Function".



AST-RHDM-SW

- for AEROSTART-EC-CF air handling unit
 - hygrostat
- (RHDM - duct-type, RHRM - indoor)

Specifications	Value	
	AST-RHDM	AST-RHRM
Ambient temperature range, °C	-20...+70	-20...+70
Outside relative humidity (without condensation), %	85	85
Enclosure ingress protection rating, IP	65	30
Air velocity inside the duct, max., m/s	12	—
Measurement range, ppm	0...100	0...100
Measurement accuracy	±2 % in the measurement range 10...90 %	±3 % in the measurement range 20...85 %

CO₂ RELAY



indoor

duct-type

AST-CO2DM-SW

- for AEROSTART-EC-CF air handling unit
 - CO₂ relay
- (CO2DM-SW - duct-type, CO2RM-SW - indoor)

- designed to control the content of carbon dioxide inside air ducts - AST-CO2DM-SW;
- designed to control the content of carbon dioxide indoors - AST-CO2RM-SW.

APPLICATION: the CO₂ relay is used to ensure the operation of the "High Intensity Ventilation Function"

Specifications	Value	
	AST-CO2DM-SW	AST-CO2RM-SW
Ambient temperature range, °C	-20...+60	-20...+60
Outside relative humidity (without condensation), %	95	95
Enclosure ingress protection rating, IP	65	30
Air velocity inside the duct, max., m/s	8	—
Measurement range, ppm	0...2 000	0...2 000
Measurement accuracy (for the measurement range at 25° C)	±50 ppm+2%	±50 ppm+2%

MOTION SENSOR



AST-MSRM

- for AEROSTART-EC-CF air handling unit
- motion sensor

- designed for motion detection in residential and office areas;
- designed for wall mounting.

APPLICATION: the motion sensor is used to ensure the operation of the "High Intensity Ventilation Function".

Specifications	Value
Ambient temperature range, °C	0...+50
Outside relative humidity (without condensation), %	85
Enclosure ingress protection rating, IP	20
Range of operation	100, distance 10 m, 80 zones

DIFFERENTIAL PRESSURE TRANSDUCERS

➤ differential pressure transducers are designed to monitor the differential pressure of air or other non-flammable and non-aggressive gases.

Possible application:

- monitoring the condition of air filters or fans, monitoring the flow in ventilation ducts;
- adjustment of air damper valves to protect heat exchangers from freezing.

The use of such sensors is mandatory for the operation of the AEROSTART-EC unit in the variable air volume (VAV) mode.



AST-AFDM

- for AEROSTART-EC-CF air handling unit
- differential pressure transducer

Specifications	Value
Ambient temperature range, °C	-10...+50
Outside relative humidity (without condensation), %	95
Enclosure ingress protection rating, IP	65